

Lea County Board of County Commissioners



Regular Meeting
Thursday, March 21, 2019 9:00 A.M.

Lea County Courthouse - Commission Chambers
100 North Main Avenue
Lovington, New Mexico

Lea County

Board of County Commissioners

Regular Meeting
Thursday, March 21, 2019 9:00 A.M.

Lea County Courthouse ~ Commission Chambers
100 North Main Avenue, Lovington, New Mexico



Lea County Board of County Commissioners Regular Meeting

Thursday, March 21, 2019 9:00 A.M.

Lea County Courthouse - Commission Chambers – 100 North Main Avenue, Lovington, New Mexico

Notice of this Meeting has been given to the Public in Compliance with Section 10-15-4 NMSA 1978

If you are an individual with a disability who is in need of a reader, amplifier, qualified sign language interpreter, or any other form of auxiliary aid or service to attend or participate in the hearing or meeting, please contact the Lea County Manager's office located in the Lea County Courthouse in Lovington, New Mexico at least one week prior to the meeting or as soon as possible. Public documents, including the agenda and minutes, can be provided in various accessible formats. Please contact the Lea County Manager's Office at the Lea County Courthouse if a summary or other type of accessible format is needed.

AGENDA

Call to Order ~ Roll Call ~ Pledge of Allegiance ~ Invocation

ITEM 01: COMMISSION

- Consideration of Lea County Resolution No. 19-MAR-089R Approving the March 7, 2019 Regular Meeting Minutes.
- Public Comments (*Non Agenda Items*).
- Commissioners and Manager Comments.
- Recognition of County Employees – Service Awards:
 - ❖ One Year
 - Eva Clayton – Detention Center
 - Catrina Pando – Detention Center
 - Randy Veerkamp – Detention Center
 - Dylan Holley – Sheriff's Office
 - ❖ Five Years
 - Sharron Long – Clerk's Office
 - Clarence Fite – Road Department
 - Samantha Capps – Assessor's Office
 - ❖ Ten Years
 - Elsie Carreon – Detention Center
- Consideration of Lea County Resolution No. 19-MAR-090R Approving Appointment(s) and/or Confirming Appointment(s) to the Lea County Road Advisory Committee.
- Consideration of Lea County Resolution No. 19-MAR-091R Designating a Subcommittee to Visit and Inspect the Lea County Detention Center.
- Consideration of Lea County Resolution No. 19-MAR-092R Authorizing In State Travel to Attend the 2019 New Mexico Broadband Summit "Connecting New Mexico – the Future of Broadband in Our State", March 22, 2019 in Albuquerque, New Mexico. (*Michael Gallagher, County Manager*)
- Consideration of Lea County Resolution No. 19-MAR-093R Authorizing In State Travel to Attend the 2019 New Mexico Counties 83rd Annual Conference, June 17 - 21, 2019 in Curry County, New Mexico. (*Michael Gallagher, County Manager*)

Chair Rebecca Long, District 2; Vice Chair Dean Jackson, District 1
Members Gary G. Eidson, District 3; Jonathan Sena, District 4; Don Jones, District 5

ITEM 02: ACTION ITEMS

- Consideration of Lea County Resolution No. 19-MAR-094R Approving Grant No. G18SN0017A Modification No. 4 between Lea County and the Office of National Drug Control Policy Increasing Funds for the High Intensity Drug Trafficking Area (HIDTA) Region VI Awarded 01/01/2018 to 12/31/2019. *(Wm Robert Sullivan, HIDTA Region VI Drug Task Force Commander)*
- Consideration of Lea County Resolution No. 19-MAR-095R Approving Grant No. G18SN0017A Modification No. 5 between Lea County and the Office of National Drug Control Policy Increasing Funds for the High Intensity Drug Trafficking Area (HIDTA) Region VI Awarded 01/01/2018 to 12/31/2019. *(Wm Robert Sullivan, HIDTA Region VI Drug Task Force Commander)*
- Consideration of Lea County Resolution No. 19-MAR-096R Approving a Memorandum of Understanding - Air Traffic Control Tower Operations Agreement between Lea County and the Federal Aviation Administration (FAA) for the Lea County Regional Airport. *(Corey Needham, Assistant County Manager)*
- Consideration of Lea County Resolution No. 19-MAR-097R Approving the 2nd Option to Renew (Proposal No. 02 2015 – 2016) Agreement between Lea County and Securus Technologies, Inc. for Inmate Telephone Equipment and Service at the Lea County Detention Center. *(Ruben Quintana, Detention Center Warden)*
- Consideration of Lea County Resolution No. 19-MAR-098R Approving Public Employees Retirement Association (PERA) Volunteer Fire Departments Annual Reporting for Knowles, Maljamar and Monument. *(Lorenzo Velasquez, Director of Emergency Management)*
- Consideration of Lea County Resolution No. 19-MAR-099R Approving a Change Order between Lea County and Lasco Construction for the North Parking Lot Gates. *(Erich Francke, Facilities Director)*
- Consideration of Lea County Resolution No. 19-MAR-100R Approving a Water Supply Equipment Replacement for the Lea County Detention Center. *(Erich Francke, Facilities Director)*
- Consideration of Lea County Resolution No. 19-MAR-101R Approving Recommendation from the Freeholders Committee Regarding the Vacation Dedicated Right of Way (ROW) of Arizona Avenue between Blocks One and Three in Camino Del Norte Subdivision in Lea County, New Mexico. *(Bruce Reid, County Planner)*
- Consideration of Lea County Resolution No. 19-MAR-102R Approving Budget Adjustment No. 02 for Lea County's Fiscal Year 2018 - 2019. *(Chip Low, Finance Director)*
- Consideration of Lea County Resolution No. 19-MAR-103R Authorizing Lea County's Fiscal Year 2019 3rd Quarter Payment and Certification for the Safety Net Care Pool Fund. *(Chip Low, Finance Director)*

ITEM 03: DISCUSSION ITEMS

- Discussion of Lea County's 2019 – 2020 FY Budget. *(Chip Low, Finance Director)*
- Discussion of Lea County's Financial Report. *(Chip Low, Finance Director)*
- Discussion of Lea County's Accounts Payable. *(Chip Low, Finance Director)*

ITEM 04: EXECUTIVE SESSION

- COMMISSION MAY CONVENE IN CLOSED SESSION to Discuss Threatened Litigation in Which the County May Become a Participant Regarding a Breach of Contract, as Authorized by the NMSA 1978 § 10-15-1 H (7).

COMMISSION MAY CONVENE IN OPEN SESSION to take Action, if any, on the Closed Session Item.

ITEM 05: OTHER BUSINESS

ADJOURN

Consideration of Lea County Resolution No. 19-MAR-089R Approving the March 7, 2019 Regular Meeting Minutes.



Minutes of Meeting
Lea County Board of Commissioners
March 7, 2019

Chair Long called the meeting to order at 9:00 a.m. in the Lea County Courthouse

Commissioners present were, to wit: Vice Chair Dean Jackson, District 1, Chair Rebecca Long, District 2, Gary G. Eidson, District 3, Commissioner Jonathan Sena, District 4, and Commissioner Richard Don Jones, District 5.

Also present were Lea County Manager Michael P. Gallagher II, and Lea County Attorney John W. Caldwell.

Commissioner Eidson led the Pledge of Allegiance followed by the Invocation by Commissioner Sena.

ITEM 01: COMMISSION

- Consideration of Lea County Resolution No. 19-MAR-072R Approving the February 28, 2019 Regular Meeting Minutes

Chair Long asked if there were any public comments concerning this agenda item. Vice Chair Jackson moved to approve Lea County Resolution No. 19-MAR-072R Approving the February 28, 2019 Regular Meeting Minutes. The motion was seconded by Commissioner Sena. Secretary polled the Commission. Chair Long, yes; Vice Chair Jackson, yes; Commissioner Eidson, yes; Commissioner Sena, yes; Commissioner Jones, yes. The motion passed.

- Public Comments

There were no public comments.

- Commissioner and Manager Comments

Commissioner Sena stated we are so proud of our Hobbs Eagles and Lady Eagles.

Commissioner Eidson stated we need to continue to pray for our legislatures.

Chair Long stated I was in Santa Fe in attendance of the Cooperation & Commissions Committee Meeting this past week. She stated I stood in favor of De-earmarking the 318 hold harmless increments.

- Consideration of Lea County Resolution No. 19-MAR-073R Approving Appointments and/or Confirming Appointments to the Lea County Road Advisory Committee

Chair Long appointed Kyle Johnston to the Lea County Road Advisory Committee. Chair Long asked if there were any public comments concerning this

STATE OF NEW MEXICO
COUNTY OF LEA
RESOLUTION NO. 19-MAR-089R
A RESOLUTION APPROVING THE LEA COUNTY
BOARD OF COUNTY COMMISSIONERS MEETING MINUTES

WHEREAS, Section 10-15-1 through 10-15-4 of the Open Meetings Act (NMSA 1978), states that, except as may be otherwise provided in the Constitution or the provisions of the Open Meetings Act, all meetings of a quorum of members of any board, council, commission or other policy making body of any state or local public agency held for the purpose of formulating public policy, discussing public business or for the purpose of taking any action within the authority of or the delegated authority of such body, are declared to be public meetings open to the public at all times; and

WHEREAS the board, commission or other policy making body shall keep written minutes of all its meetings. The minutes shall include at a minimum the date, time and place of the meeting, the names of members in attendance and those absent, the substance of the proposals considered and a record of any decisions and votes taken that show how each member voted; and

WHEREAS all minutes are open to public inspection. Draft minutes shall be prepared within ten working days after the meeting and shall be approved, amended or disapproved at the next meeting where a quorum is present. Minutes shall not become official until approved by the policymaking body.

WHEREAS, NMSA 1978, Section 4-38-12 as amended, allows the County Commission to establish rules and regulations to govern the transaction of county business in these meetings.

NOW, THEREFORE, BE IT RESOLVED by the Board of County Commissioners of Lea County that the attached minutes are hereby approved.

PASSED AND APPROVED on this 21st day of March, 2019, by the Lea County Board of County Commissioners in an open meeting in Lovington, New Mexico.

LEA COUNTY BOARD OF COUNTY COMMISSIONERS

Rebecca Long (District 2), Chair
Voted: Yes No Abstain

Dean Jackson (District 1), Vice Chair
Voted: Yes No Abstain

Gary G. Eidson (District 3), Member
Voted: Yes No Abstain

Jonathan Sena (District 4), Member
Voted: Yes No Abstain



**LEA COUNTY BOARD OF COUNTY COMMISSIONERS
AGENDA ITEM SUMMARY FORM**

LCBCC Meeting Date: Thursday, March 21, 2019

Submit this summary form & all attachments to the Finance Director clow@leacounty.net & cc the Executive Coordinator sstout@leacounty.net by: **March 5, 2019**

County Manager Approval (mgallagher@leacounty.net) required for all time sensitive issues that do not meet the above deadline.

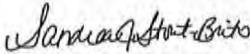
DATE SUBMITTED mm-dd-yyyy: 03/11/2019		SUBMITTED BY Name/Title/Dept: Kelli Williams, Recording Secretary/Deputy Clerk, Clerk's Office	
SUBJECT: Minutes		ATTACHMENT(S): Resolution Draft Minutes	
NO. OF ORIGINALS FOR SIGNATURE: 01 Resolution 01 Minutes 00 ***Select One**		ACTION REQUESTED: Action Item	
STRATEGIC PLAN Implementation of 5 Year Strategic Plan: Section 2 - 6: Transparency and ethical decision making continue to be the framework in which the county operates.			
SUMMARY: See attached draft minutes for the following LCBCC meetings: March 7, 2019 Regular Meeting			
Requested Items Needed for Presentation Easels/Laptop/Projector/Etc.: Easel <input type="checkbox"/> Laptop <input checked="" type="checkbox"/> Projector <input checked="" type="checkbox"/> Other:		See Additional Summary Attached <input type="checkbox"/>	
SUBMITTER'S RECOMMENDATION(S): Review & Approve Minutes		Submitter's Signature Department Director, Etc. 	
FINANCE REVIEW Fiscal Impact/Cost: ByPass Finance Review		Reviewed by Finance Director ByPass Finance Review Digitally signed by ByPass Finance Review Date: 2019.03.19 15:22:45 -06'00'	
LEGAL REVIEW: ByPass Legal Review (Note: Travel does not need legal review)		Reviewed by County Attorney ByPass Legal Review Digitally signed by ByPass Legal Review Date: 2019.03.19 15:22:57 -06'00'	
COUNTY MANAGER REVIEW: 03/11: Reviewed by LCBCC D4 with Changes; 03/11: Reviewed by LCBCC D3		Approved by County Manager to be Placed on Agenda Digitally signed by Michael P. Gallagher II Date: 2019.03.19 14:00:45 -06'00'	
Item 0101 RECORDING SECRETARY'S USE ONLY ~ COMMISSION ACTION TAKEN			
Approved: _____ Resolution No. <u>19-MAR-089R</u> Continued To: _____		Denied: _____ Policy No. _____ Referred To: _____	
		Other: _____ Ordinance No. _____ Comments: _____	

STATE OF NEW MEXICO
COUNTY OF LEA
RESOLUTION NO. 19-MAR-089R

**A RESOLUTION APPROVING THE LEA COUNTY
BOARD OF COUNTY COMMISSIONERS MEETING MINUTES**

WHEREAS, Section 10-15-1 through 10-15-4 of the Open Meetings Act (NMSA 1978), states that, except as may be otherwise provided in the Constitution or the provisions of the Open Meetings Act, all meetings of a quorum of members of any board, council, commission or other policy making body of any state or local public agency held for the purpose of formulating public policy, discussing public business or for the purpose of taking any action within the authority of or the delegated authority of such body, are declared to be public meetings open to the public at all times; and

WHEREAS the board, commission or other policy making body shall keep written minutes of all its meetings. The minutes shall include at a minimum the date, time and place of the meeting, the names of members in attendance and those absent, the substance of the proposals considered and a record of any decisions and votes taken that show how each member voted; and

WHEREAS all minutes are open to public inspection. Draft minutes shall be prepared within ten working days after the meeting and shall be approved, amended or disapproved at the next meeting where a quorum is present. Minutes shall not become official until approved by the policymaking body.

WHEREAS, NMSA 1978, Section 4-38-12 as amended, allows the County Commission to establish rules and regulations to govern the transaction of county business in these meetings.

NOW, THEREFORE, BE IT RESOLVED by the Board of County Commissioners of Lea County that the attached minutes are hereby approved.

PASSED AND APPROVED on this 21st day of March, 2019, by the Lea County Board of County Commissioners in an open meeting in Lovington, New Mexico.

LEA COUNTY BOARD OF COUNTY COMMISSIONERS

Rebecca Long (District 2), Chair
Voted: Yes No Abstain

Dean Jackson (District 1), Vice Chair
Voted: Yes No Abstain

Gary G. Eidson (District 3), Member
Voted: Yes No Abstain

Jonathan Sena (District 4), Member
Voted: Yes No Abstain

Richard Don Jones (District 5), Member
Voted: Yes No Abstain

ATTEST: Keith Manes
Lea County Clerk

**APPROVED AS TO FORM AND LEGAL
SUFFICIENCY:**

By: _____
Kelli Williams, Deputy Clerk

John W. Caldwell, County Attorney

**Minutes of Meeting
Lea County Board of Commissioners
March 7, 2019**

Chair Long called the meeting to order at 9:00 a.m. in the Lea County Courthouse

Commissioners present were, to wit: Vice Chair Dean Jackson, District 1, Chair Rebecca Long, District 2, Gary G. Eidson, District 3, Commissioner Jonathan Sena, District 4, and Commissioner Richard Don Jones, District 5.

Also present were Lea County Manager Michael P. Gallagher II, and Lea County Attorney John W. Caldwell.

Commissioner Eidson led the Pledge of Allegiance followed by the Invocation by Commissioner Sena.

ITEM 01: COMMISSION

- Consideration of Lea County Resolution No. 19-MAR-072R Approving the February 28, 2019 Regular Meeting Minutes

Chair Long asked if there were any public comments concerning this agenda item. Vice Chair Jackson moved to approve Lea County Resolution No. 19-MAR-072R Approving the February 28, 2019 Regular Meeting Minutes. The motion was seconded by Commissioner Sena. Secretary polled the Commission. Chair Long, yes; Vice Chair Jackson, yes; Commissioner Eidson, yes; Commissioner Sena, yes; Commissioner Jones, yes. The motion passed.

- Public Comments

There were no public comments.

- Commissioner and Manager Comments

Commissioner Sena stated we are so proud of our Hobbs Eagles and Lady Eagles.

Commissioner Eidson stated we need to continue to pray for our legislatures.

Chair Long stated I was in Santa Fe in attendance of the Cooperation & Commissions Committee Meeting this past week. She stated I stood in favor of De-earmarking the 318 hold harmless increments.

- Consideration of Lea County Resolution No. 19-MAR-073R Approving Appointments and/or Confirming Appointments to the Lea County Road Advisory Committee

Chair Long appointed Kyle Johnston to the Lea County Road Advisory Committee. Chair Long asked if there were any public comments concerning this

agenda item. Vice Chair Jackson moved to approve Lea County Resolution No. 19-MAR-073R Approving Appointments and/or Confirming Appointments to the Lea County Road Advisory Committee. The motion was seconded by Commissioner Sena. Secretary polled the Commission. Chair Long, yes; Vice Chair Jackson, yes; Commissioner Eidson, yes; Commissioner Sena, yes; Commissioner Jones, yes. The motion passed.

- Consideration of Lea County Resolution No. 19-MAR-074R Approving Appointments and/or Confirming Appointments to the New Horizons Foundation Board of Directors

Commissioner Jones nominated Gary Eidson to join the New Horizons Board of Directors. Chair Long asked if there were any public comments concerning this agenda item. Commissioner Jones moved to approve Lea County Resolution No. 19-MAR-074R Approving Appointments and/or Confirming Appointments to the New Horizons Foundation Board of Directors. The motion was seconded by Commissioner Sena. Secretary polled the Commission. Chair Long, yes; Vice Chair Jackson, yes; Commissioner Eidson, yes; Commissioner Sena, yes; Commissioner Jones, yes. The motion passed.

Chair Long recognized the City of Tatum Chief of Police Mae Jackson for her attendance.

ITEM 02: ACTION ITEMS

- Consideration of Lea County Resolution No. 19-MAR-075R Authorizing the Approval and Execution of an Application for Law Enforcement Protection Funds (LEPF) for FY 2019-2020 (Corey Helton, County Sheriff)

Chief Deputy Jimenez in lieu of Sheriff Helton requested approval. Chair Long asked if there were any public comments concerning this agenda item. Vice Chair Jackson moved to approve Lea County Resolution No. 19-MAR-075R Authorizing the Approval and Execution of an Application for Law Enforcement Protection Funds (LEPF) for FY 2019-2020. The motion was seconded by Commissioner Sena. Secretary polled the Commission. Chair Long, yes; Vice Chair Jackson, yes; Commissioner Eidson, yes; Commissioner Sena, yes; Commissioner Jones, yes. The motion passed.

- Consideration of Lea County Resolution No. 19-MAR-076R Approving an Amendment to Agreement between Lea County and the Town of Tatum (Funding of Infrastructure and Facilities – Dated September 20, 2018) to Allow the Purchase of Law and Public Safety Equipment/Supplies and Extend Deadline (Michael Gallagher, County Manager)

Manager Gallagher requested approval. Chair Long asked if there were any public comments concerning this agenda item. Vice Chair Jackson moved to approve Lea Resolution No. 19-MAR-076R Approving an Amendment to Agreement between Lea County and the Town of Tatum (Funding of Infrastructure and facilities – Dated September 20, 2018) to Allow the Purchase of Law and Public Safety Equipment/Supplies and Extend Deadline. The motion was seconded by Commissioner Eidson. Secretary polled the Commission. Chair Long, yes; Vice Chair Jackson, yes; Commissioner Eidson, yes; Commissioner Sena, yes; Commissioner Jones, yes. The motion passed.

- Consideration of Lea County Resolution No. 19-MAR-077R Approving County Manager Employment Agreement (Chair Rebecca Long, Commissioner District 2)

Chair Long requested approval. Commissioner Sena made comments in approval of this Resolution and thanking Manager Gallagher for a job well done. Chair Long asked if there were any public comments concerning this agenda item. Mara Salcido from Lovington Main Street made comments in support of Manager Gallagher. Commissioner Eidson moved to approve Lea County Resolution No. 19-MAR-077R Approving County Manager Employment Agreement. The motion was seconded by Commissioner Sena. Secretary polled the Commission. Chair Long, yes; Vice Chair Jackson, yes; Commissioner Eidson, yes; Commissioner Sena, yes; Commissioner Jones, yes. The motion passed.

- Consideration of Lea County Resolution No. 19-MAR-078R Approving Assistant County Manager Employment Agreement (Michael Gallagher, County Manager)

Manager Gallagher requested approval. Chair Long asked if there were any public comments concerning this agenda item. Vice Chair Jackson moved to approve Lea County Resolution No. 19-MAR-078R Approving Assistant County Manager Employment Agreement. The motion was seconded by Commissioner Jones. Secretary polled the Commission. Chair Long, yes; Vice Chair Jackson, yes; Commissioner Eidson, yes; Commissioner Sena, yes; Commissioner Jones, yes. The motion passed.

- Consideration of Lea County Resolution No. 19-MAR-079R Approving County Attorney Employment Agreement (Michael Gallagher, County Manager)

Manager Gallagher requested approval. Chair Long asked if there were any public comments concerning this agenda item. Commissioner Eidson moved to approve Lea County Resolution No. 19-MAR-079R Approving County Attorney Employment Agreement. The motion was seconded by Commissioner Sena. Secretary polled the Commission. Chair Long, yes; Vice Chair Jackson, yes; Commissioner Eidson, yes; Commissioner Sena, yes; Commissioner Jones, yes. The motion passed.

- Consideration of Lea County Resolution No. 19-MAR-080R Authorizing In State Travel to Attend the Professional Standards Council Meeting, March 18-19, 2019 In Las Cruces, New Mexico (Michael Gallagher, County Manager)

Manager Gallagher requested approval. Chair Long asked if there were any public comments concerning this agenda item. Vice Chair Jackson moved to approve Lea County Resolution No. 19-MAR-080R Authorizing In State Travel to Attend the Professional Standards Council Meeting, March 18-19-2019 in Las Cruces, New Mexico. The motion was seconded by Commissioner Jones. Secretary polled the Commission. Chair Long; yes, Vice Chair Jackson, yes; Commissioner Eidson, yes; Commissioner Sena, yes; Commissioner Jones, yes. The motion passed.

- Consideration of Lea County Resolution No. 19-MAR-081R Approving a Grant Agreement No. E26-19-03 between Lea County and the New Mexico Department of Transportation to Replace Plasi with PAPI at the Lea County Jal Airport (Corey Needham, Assistant County Manager – Operations)

Assistant County Manager of Operations Needham requested approval. Chair Long asked if there were any public comments concerning this agenda item. Commissioner Eidson moved to approve Lea County Resolution No. 19-MAR-081R Approving a Grant Agreement No. E26-19-03 between Lea County and the New Mexico Department of Transportation to Replace Plasi with PAPI at the Lea County Jal Airport. The motion was seconded by Commissioner Jones. Secretary polled the Commission. Chair Long, yes; Vice Chair Jackson, yes; Commissioner Eidson, yes; Commissioner Sena, yes; Commissioner Jones, yes. The motion passed.

- Consideration of Lea County Resolution No. 19-MAR-082R Approving Task Order No. 2015-37 with Molzen Corbin for Engineering Services Related to PAPI Installation at the Lea County Jal Airport (Corey Needham, Assistant County Manager – Operations)

Assistant County Manager of Operations Needham requested approval. Chair Long asked if there were any public comments concerning this agenda item. Vice Chair Jackson moved to approve Lea County Resolution No. 19-MAR-082R Approving Task Order No. 2015-37 with Molzen Corbin for Engineering Services Related to PAPI Installation at the Lea County Jal Airport. The motion was seconded by Commissioner Jones. Secretary polled the Commission. Chair Long, yes; Vice Chair Jackson, yes; Commissioner Eidson, yes; Commissioner Sena, yes; Commissioner Jones, yes. The motion passed.

- Consideration of Lea County Resolution No. 19-MAR-083R Approving a Grant Agreement No. E06-19-02 between Lea County and the New Mexico Department of Transportation to Install New Electrical Vault at the Zip Franklin Memorial Airport (Corey Needham, Assistant County Manager – Operations)

Assistant County Manager of Operations Needham requested approval. Chair Long asked if there were any public comments concerning this agenda item. Vice Chair Jackson moved to approve Lea County Resolution No. 19-MAR-083R Approving a Grant Agreement No. E06-19-02 between Lea County and the New Mexico Department of Transportation to Install New Electrical Vault at the Zip Franklin Memorial Airport. The motion was seconded by Commissioner Jones. Secretary polled the Commission. Chair Long, yes; Vice Chair Jackson, yes; Commissioner Eidson, yes; Commissioner Sena, yes; Commissioner Jones, yes. The motion passed.

- Consideration of Lea County Resolution No. 19-MAR-84R Approving Task Order No. 2015-38 with Molzen Corbin for Engineering Services Related to the Installation of a New Electrical Vault at the Zip Franklin Memorial Airport (Corey Needham, Assistant County Manager – Operations)

Assistant County Manager of Operations Needham requested approval. Chair Long asked if there were any public comments concerning this agenda item. Vice Chair Jackson moved to approve Lea County Resolution No. 19-MAR-084R Approving Task Order No. 2015-38 with Molzen Corbin for Engineering Services Related to the Installation of a New Electrical Vault at the Zip Franklin Memorial Airport. The motion was seconded by Commissioner Eidson. Secretary polled the Commission. Chair Long, yes; Vice Chair Jackson, yes; Commissioner Eidson, yes; Commissioner Sena, yes; Commissioner Jones, yes. The motion passed.

- Consideration of Lea County Resolution No. 19-MAR-085R Approving the 2019 Annual Certified County Maintained Mileage Report (Corey Needham, Assistant County Manager – Operations)

Assistant County Manager of Operations Needham requested approval. Chair Long asked if there were any public comments concerning this agenda item. Commissioner Eidson moved to approve Lea County Resolution No. 19-MAR-085R Approving the 2019 Annual Certified County Maintained Mileage Report. The motion was seconded by Vice Chair Jackson. Secretary polled the Commission. Chair Long, yes; Vice Chair Jackson, yes; Commissioner Eidson, yes; Commissioner Sena, yes; Commissioner Jones, yes. The motion passed.

- Consideration of Lea County Resolution No. 19-MAR-086R Approving a Cooperative Educational Services (CES) Agreement between Lea County and Ramirez & Sons for the Paving of the Lea County Fairgrounds South Parking Lot (Erich Francke, Facilities Director)

Director Francke requested approval. Chair Long asked if there were any public comments concerning this agenda item. Vice Chair Jackson moved to approve Lea County Resolution No. 19-MAR-086R Approving a Cooperative Educational Services (CES) Agreement between Lea County and Ramirez & Sons for the Paving of the Lea County Fairgrounds South Parking Lot. The motion was seconded by Commissioner

Jones. Secretary polled the Commission. Chair Long, yes; Vice Chair Jackson, yes; Commissioner Eidson, yes; Commissioner Sena, yes; Commissioner Jones, yes. The motion passed.

- Consideration of Lea County Resolution No. 19-MAR-087R Approving Lea County's Salary Matrix (Craig Bova, Human Resources Director)

Director Bova requested approval. Chair Long asked if there were any public comments concerning this agenda item. Vice Chair Jackson moved to approve Lea County Resolution No. 19-MAR-087R Approving Lea County's Salary Matrix. The motion was seconded by Commissioner Sena. Secretary polled the Commission. Chair Long, yes; Vice Chair Jackson, yes; Commissioner Eidson, yes; Commissioner Sena, yes; Commissioner Jones, yes. The motion passed.

- Consideration of Lea County Resolution No. 19-MAR-088R Approving Recommendation from the Freeholders Committee Regarding the Vacation Dedicated Right of Way (ROW) of Arizona Avenue between Blocks One and Three in Camino Del Norte Subdivision in Lea County, New Mexico (Bruce Reid, County Planner)

County Planner Reid requested approval. Chair Long asked if there were any public comments concerning this agenda item. Vice Chair Jackson moved to postpone Lea County Resolution No. 19-MAR-088R Approving Recommendation from the Freeholders Committee Regarding the Vacation Dedicated Right of Way (ROW) of Arizona Avenue between Blocks One and Three in Camino Del Norte Subdivision in Lea County, New Mexico. The motion was seconded by Commissioner Eidson. Secretary polled the Commission. Chair Long, yes; Vice Chair Jackson, yes; Commissioner Eidson, yes; Commissioner Sena, yes; Commissioner Jones, yes. The motion passed.

ITEM 03: DISCUSSION ITEMS

- Discussion of Lea County Road Projects (Corey Needham, Assistant County Manager – Operations)

Assistant County Manager of Operations Needham presented a discussion of Lea County Road Projects.

ITEM 05: OTHER BUSINESS

There was no other business.

The meeting was adjourned at 9:44 a.m.

**BOARD OF COUNTY COMMISSIONERS
LEA COUNTY, NEW MEXICO**

Rebecca Long, Chair

Dean Jackson, Vice Chair

Gary G. Eidson, Member

Jonathan Sena, Member

Richard Don Jones, Member

**ATTEST: Keith Manes
Lea County Clerk**

Kelli Williams

Public Comments (Non Agenda Items).

1





LEA COUNTY BOARD OF COUNTY COMMISSIONERS

PUBLIC COMMENT SUMMARY FORM

Thursday, March 21, 2019 9:00 A.M.

LCBCC MEETING

Lea County Courthouse – Commission Chambers 1st Floor
100 North Main Avenue , Lovington, New Mexico 882620 575.396-8602

Submit this summary form to the Lea County Manager's Office at leacounty@leacounty.net by:

Tuesday, March 19, 2019

DATE SUBMITTED:	SUBMITTED BY:
CONTACT INFO: Phone No.: _____ Email Address: _____ Mailing Address: _____ _____	Please check in with the Lea County Manager prior to the start of the meeting. See attached Lea County Resolution No. 19-JAN-017R Open Meetings and Procedures.
SUMMARY OF PUBLIC COMMENT:	
<div style="background-color: #cccccc; padding: 5px;"> <p><small>Item 0102</small> RECORDING SECRETARY'S USE ONLY</p> <p>Comments: _____</p> <p>_____</p> </div>	

**STATE OF NEW MEXICO
COUNTY OF LEA
RESOLUTION NO. 19-JAN-017R**

OPEN MEETINGS PROCEDURES

WHEREAS, Section 10-15-1(B) of the Open Meetings Act (NMSA 1978) states that, except as may be otherwise provided in the Constitution or the provisions of the Open Meetings Act, all meetings of a quorum of members of any board, council, commission or other policy making body of any state or local public agency held for the purpose of formulating public policy, discussing public business or for the purpose of taking any action within the authority of or the delegated authority of such body, are declared to be public meetings open to the public at all times; and

WHEREAS, any meetings subject to the Open Meetings and held for the purpose of formulating public policy, discussing public business or for the purpose of taking any action within the authority of or the delegated authority of the Board of County Commissioners of Lea County (hereinafter "County Commission") shall be held only after reasonable notice to the public; and

WHEREAS, the Open Meetings Act, NMSA 1978, Section 10-15-1(D), requires the County Commission to determine annually what constitutes reasonable notice of its public meetings; and

WHEREAS, NMSA 1978, Section 4-38-12 as amended, allows the County Commission to establish rules and regulations to govern the transaction of county business in these meetings.

NOW, THEREFORE, BE IT RESOLVED that:

1. All meetings of the County Commission will be held at the Commission Meeting Room at the Lea County Courthouse, 100 N. Main, Lovington, New Mexico 88260, at 9:00 a.m. or as otherwise indicated in the meeting notice.
2. Unless otherwise noticed, there will be two regular meetings each month held on the date announced at the prior meeting. Notice of regular meetings will be given at least seven days in advance. The agenda will be available at least seventy-two (72) hours in advance of regular Commission Meetings from the office of the County Manager located on the fourth floor of the Lea County Courthouse, Lovington, New Mexico 88260 and posted on the Lea County website (www.leacounty.net). In addition, a meeting agenda will be sent to all broadcast stations licensed by the Federal Communications Commission and newspapers of general circulation that have provided a written request for such notice. The agenda will indicate the time, date, place and specific items to be discussed during the County Commission meeting. The County Commission shall take action only on items appearing on the agenda.
3. In addition to the Board's regular meetings, work sessions and special meetings may be called at the discretion of the Chair or upon the request of two Commissioners upon seventy-two (72) hours notice, in accordance with paragraph 5. The final agenda for work sessions

and special meetings shall be available at least seventy-two (72) hours in advance of the work session or special meeting.

4. Emergency meetings will be called only under unforeseen circumstances that, if not addressed immediately by the County Commission, will likely result in injury or damage to persons or property or substantial financial loss to Lea County. The County Commission will avoid emergency meetings whenever possible. Emergency meetings may be called by the Chair or any two Commissioners upon twenty-four hours (24) notice, unless a threat of personal injury, property damage or substantial financial loss requires less notice. The notice for all emergency meetings shall include an agenda for the meeting or information on how the public may obtain a copy of the agenda. Within ten days of taking action on an emergency matter, the County Commission shall report to the attorney general's office the action taken and the circumstances creating the emergency; provided that the requirement to report to the attorney general is waived upon the declaration of a state or national emergency.
5. For the purposes of regular meetings described in paragraph two of this resolution, as well as special meetings and work sessions described in paragraph three of this resolution, notice requirements are met if notice of the date, time, place and agenda or information on how the public may obtain a copy of such an agenda is posted on the Lea County website and provided to all broadcast stations licensed by the Federal Communications Commission and newspapers of general circulation that have provided a written request for such notice.
6. For the purposes of emergency meetings described in paragraph four of this resolution, notice requirements shall be met if notice of the date, time, place and agenda is posted on the outermost doors of the Courthouse and in the offices of the County Manager, who shall also provide telephonic notice to those broadcast stations licensed by the Federal Communications Commission and newspapers of general circulation that have made a written request for notice of public meetings.
7. In addition to the information specified above, all notices shall include the following language:

If you are an individual with a disability who is in need of a reader, amplifier, qualified sign language interpreter, or any other form of auxiliary aid or service to attend or participate in the hearing or meeting, please contact the Lea County Manager's office located in the Lea County Courthouse in Lovington, New Mexico at least one week prior to the meeting or as soon as possible. Public documents, including the agenda and minutes, can be provided in various accessible formats. Please contact the Lea County Manager's Office at the Lea County Courthouse if a summary or other type of accessible format is needed.
8. The County Commission may close a meeting to the public only if the subject matter of such discussion or action is exempted from the open meeting requirements under the Open Meetings Act, Section 10-15-1(H) NMSA 1978 Comp.
 - A. If any meeting is closed during an open meeting, such closure shall be approved by a majority vote of a quorum of the County Commission taken during the open meeting.

The authority for the closure and the subjects to be discussed shall be stated in the motion for closure and the vote on closure of each individual member shall be recorded in the minutes. Only those subjects specified in the motion may be discussed in a closed meeting.

- B. If a closed meeting is conducted when the County Commission is not in an open meeting, the closed meeting shall not be held until public notice, appropriate under the circumstances, stating the specific provision of law authorizing the closed meeting and the subjects to be discussed with reasonable specificity, is given to the members and to the general public.
 - C. Following completion of any closed meeting, the minutes of the open meeting that was closed, or the minutes of the next open meeting if the closed meeting was separately scheduled, shall state whether the matters discussed in the closed meeting were limited only to those specified in the motion or notice for closure.
 - D. Except as provided in Section 10-15-1(H) of the Open Meetings Act, any action taken as a result of discussions in a closed meeting shall be made by vote of the County Commission in an open public meeting.
9. The notice requirements set forth above in paragraphs two, three, and four shall apply to all Boards and Committees appointed by the County Commission.
10. The public may address the County Commission on county matters not listed on a meeting's agenda during the portion of the meeting identified as Public Input. All persons, agencies or organizations who desire to discuss public business or matters with the County Commission at a County Commission meeting, must make their request to the County Manager prior to the commencement of the County Commission meeting.
- A. The request may be oral or written and must include the name of the person making the request and the subject on which they wish to address the County Commission. Such persons addressing the County Commission will be limited to three (3) minutes.
 - B. All persons, agencies or organizations that require additional time to discuss public business or matters with the County Commission, must make their request, in writing, at least seven (7) days prior to the County Commission meeting. Such persons addressing the County Commission will be allowed up to fifteen (15) minutes in the discretion of the Chairman.
11. On matters involving agenda items, the Chair will ask for public comments before any vote or other action is taken by the County Commission. Such comments will be limited to three (3) minutes.

12. The County Commission may, by Resolution, adopt additional rules and regulations regarding the conduct of the meetings of the County Commission and any of its subordinate Boards or Committees.

PASSED, APPROVED and ADOPTED on this 7th day of January, 2019, by the Lea County Board of County Commissioners in an open meeting in Lovington, New Mexico.

LEA COUNTY BOARD OF COUNTY COMMISSIONERS



Rebecca Long (District 2), Chair
Voted: Yes No Abstain



Dean Jackson (District 1), Vice Chair
Voted: Yes No Abstain

*Lea County
JAN 07 2019
LCBCC Meeting*



Gary G. Eidson (District 3), Member
Voted: Yes No Abstain



Jonathan Sena (District 4), Member
Voted: Yes No Abstain



Richard Don Jones (District 5), Member
Voted: Yes No Abstain

ATTEST: Keith Manes
Lea County Clerk

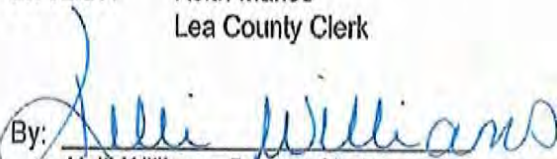
By: 

Kelli Williams, Deputy Clerk

APPROVED AS TO FORM AND LEGAL SUFFICIENCY:

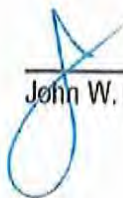

John W. Caldwell, County Attorney



Commissioners and Manager Comments

1





**LEA COUNTY BOARD OF COUNTY COMMISSIONERS
AGENDA ITEM SUMMARY FORM**

LCBCC Meeting Date: Thursday, March 21, 2019

Submit this summary form & all attachments to the Finance Director clow@leacounty.net & cc the Executive Coordinator sstout@leacounty.net by: **March 5, 2019**

County Manager Approval (mgallagher@leacounty.net) required for all time sensitive issues that do not meet the above deadline.

DATE SUBMITTED mm-dd-yyyy: 03/19/2019		SUBMITTED BY Name/Title/Dept: Sandra J. Stout-Brito/Executive Coordinator/Exec Dept.	
SUBJECT: Commission/Manager Comments		ATTACHMENT(S):	
NO. OF ORIGINALS FOR SIGNATURE: 00 ***Select One** 00 ***Select One** 00 ***Select One**		ACTION REQUESTED: Discussion Item	
STRATEGIC PLAN Implementation of 5 Year Strategic Plan: Section 2.3: Continuous communication with the public is beneficial and necessary.			
SUMMARY: Comments from the Commissioners & County Manager			
Requested Items Needed for Presentation Easels/Laptop/Projector/Etc.: Easel <input type="checkbox"/> Laptop <input checked="" type="checkbox"/> Projector <input checked="" type="checkbox"/> Other:		See Additional Summary Attached <input type="checkbox"/>	
SUBMITTER'S RECOMMENDATION(S): Discussion Only		Submitter's Signature Department Director, Etc. 	
FINANCE REVIEW Fiscal Impact/Cost: ByPass Finance Review		Reviewed by Finance Director ByPass Finance Review Digitally signed by ByPass Finance Review Date: 2019.03.19 17:36:35 -06'00'	
LEGAL REVIEW: ByPass Legal Review (Note: Travel does not need legal review)		Reviewed by County Attorney ByPass Legal Review Digitally signed by ByPass Legal Review Date: 2019.03.19 17:36:45 -06'00'	
COUNTY MANAGER REVIEW:		Approved by County Manager to be Placed on Agenda Digitally signed by Michael P. Gallagher II Date: 2019.03.19 14:00:45 -06'00'	
Item 0103 RECORDING SECRETARY'S USE ONLY ~ COMMISSION ACTION TAKEN			
Approved: _____ Resolution No. _____ Continued To: _____	Denied: _____ Policy No. _____ Referred To: _____	Other: <u>Discussion</u> Ordinance No. _____ Comments: _____	

1 Year

Eva Clayton – Detention

Catrina Pando – Detention

Randy Veerkamp – Detention

Dylan Holley – Sheriff's Office

5 Years

Sharron Long – Clerk

Clarence Fite – Road

Samantha Capps - Assessor

10 Years

Elsie Carreon - Detention





**LEA COUNTY BOARD OF COUNTY COMMISSIONERS
AGENDA ITEM SUMMARY FORM**

LCBCC Meeting Date: Thursday, March 21, 2019

Submit this summary form & all attachments to the Finance Director cflow@leacounty.net & cc the Executive Coordinator sshout@leacounty.net by: **March 5, 2019**

County Manager Approval (mgallagher@leacounty.net) required for all time sensitive issues that do not meet the above deadline.

DATE SUBMITTED mm-dd-yyyy: 03/05/2019		SUBMITTED BY Name/Title/Dept: Craig Bova/HR Director/Human Resources	
SUBJECT: Recognition of County Employees		ATTACHMENT(S):	
NO. OF ORIGINALS FOR SIGNATURE: 00 ***Select One** 00 ***Select One** 00 ***Select One**		ACTION REQUESTED: Discussion Item	
STRATEGIC PLAN Implementation of 5 Year Strategic Plan: Employees are valued			
SUMMARY: Recognize the following employees for years of service. Eva Clayton - Detention - 1 year Elsie Carreon - Detention - 10 years Catrina Pando - Detention - 1 year Randy Veerkamp - Detention - 1 year Dylan Holley - Sheriff's Office - 1 year Sharon Long - Clerk's Office - 5 years Clarence Fite - Road - 5 years Samantha Capps - Assessor - 5 years			
Requested Items Needed for Presentation Easels/Laptop/Projector/Etc.:		See Additional Summary Attached <input type="checkbox"/>	
Easel <input type="checkbox"/> Laptop <input checked="" type="checkbox"/> Projector <input checked="" type="checkbox"/> Other: _____ <small>If checked, how many:</small>			
SUBMITTER'S RECOMMENDATION(S): Recognize employees		Submitter's Signature Department Director, Etc. Craig Bova <small>Digitally signed by Craig Bova DN: cn=Craig Bova, o=Lea County, ou=Human Resources, email=cflow@leacounty.net, c=US Date: 2019.03.05 11:28:43 -0700</small>	
FINANCE REVIEW Fiscal Impact/Cost:		Reviewed by Finance Director	
LEGAL REVIEW: (Note: Travel does not need legal review)		Reviewed by County Attorney	
COUNTY MANAGER REVIEW:		Approved by County Manager to be Placed on Agenda <i>Michael P. Gallagher</i> Digitally signed by Michael P. Gallagher Date: 2019.03.20 08:28:47 -06'00'	
Item 0104 RECORDING SECRETARY'S USE ONLY ~ COMMISSION ACTION TAKEN			
Approved: _____	Denied: _____	Other: <u>Presentation</u> _____	
Resolution No. _____	Policy No. _____	Ordinance No. _____	
Continued To: _____	Referred To: _____	Comments: _____	

Consideration of Lea County Resolution No. 19-MAR-090R Approving Appointment(s) and/or Confirming Appointment(s) to the Lea County Road Advisory Committee.



Lea County Roads Advisory Committee:

- District 1: Brad Woody (Term 01/01/2018-12/31/2019)
- District 1: Randy Pettigrew (Term 01/01/2019-12/31/2020)
- District 2: Replace Mark Gainer with _____
(Term 01/01/2018-12/31/2019)**
- District 2: Kyle Johnston (Term 01/01/2019-12/31/2020)
- District 3: Ken Batson (Term 01/01/2018-01/02/2019)
- District 3: TJ Parks (Term 01/01/2019-12/31/2020)
- District 4: Vivian Flemens (Term 01/01/2018-12/31/2019)
- District 4: Mark Bateman (Term 01/01/2019-12/31/2020)
- District 5: James Smith (Term 01/01/2018-12/31/2019)
- District 5: Cindy Shoobridge (Term 01/01/2019-12/31/2020)

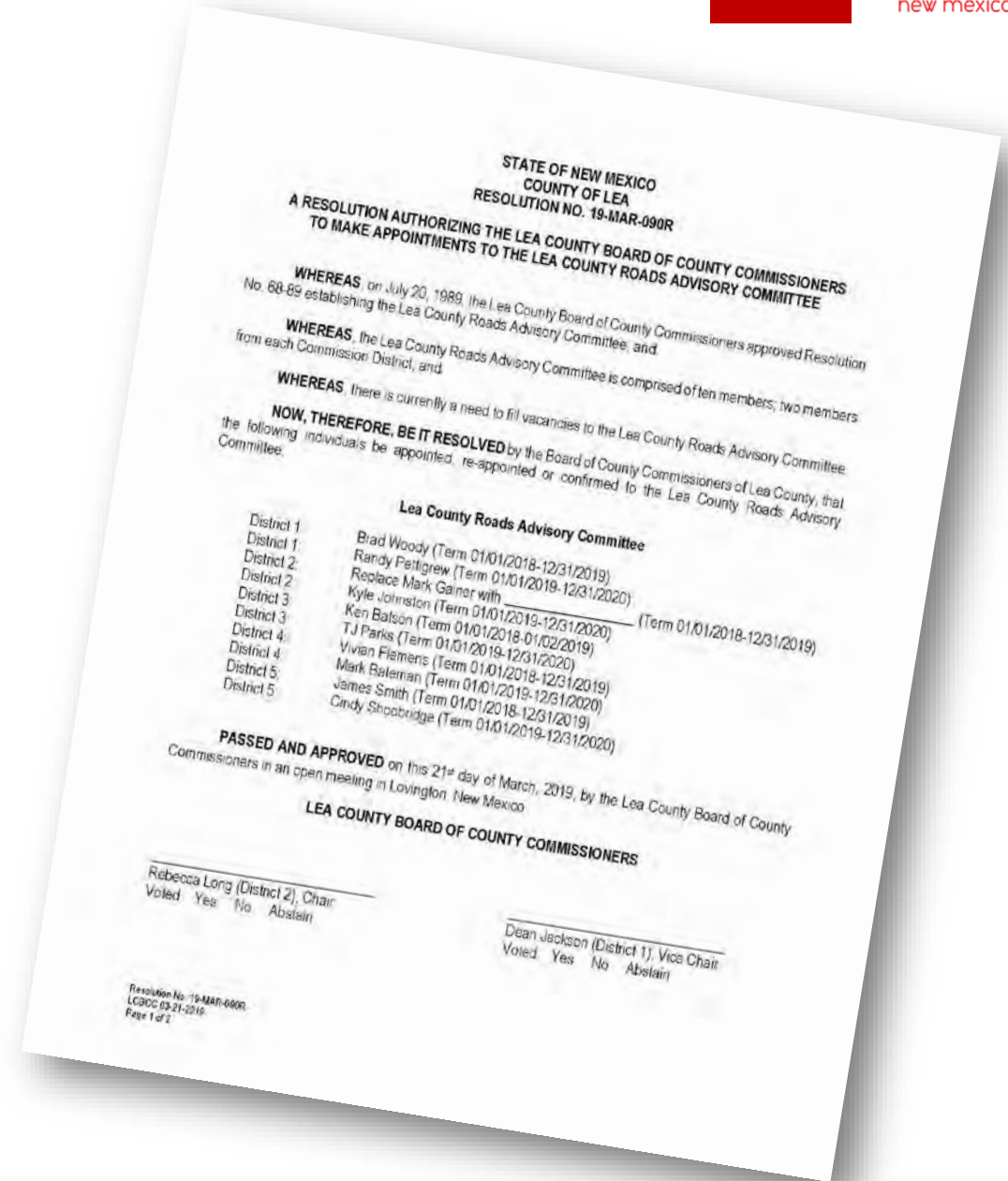



**LEA COUNTY BOARD OF COUNTY COMMISSIONERS
AGENDA ITEM SUMMARY FORM**

LCBCC Meeting Date: Thursday, March 21, 2019

Submit this summary form & all attachments to the Finance Director cjow@leacounty.net & cc the Executive Coordinator sstout@leacounty.net by: **March 5, 2019**

County Manager Approval (mgallagher@leacounty.net) required for all time sensitive issues that do not meet the above deadline.

DATE SUBMITTED mm-dd-yyyy: 03/19/2019		SUBMITTED BY Name/Title/Dept: Sandrea J. Stout-Brito/Executive Coordinator/Exec Dept.	
SUBJECT: Appointments to the Lea County Roads Advisory Committee		ATTACHMENT(S): Resolution	
NO. OF ORIGINALS FOR SIGNATURE: 01 Resolution 00 ***Select One** 00 ***Select One**		ACTION REQUESTED: Action Item	
STRATEGIC PLAN Implementation of 5 Year Strategic Plan: Section 2.3 Continuous communication with the public is beneficial and necessary. Section 2.4 Leverage resources to the fullest extent to maximize the return to the public and minimize cost to tax payer. Section 2.5 Public and employee involvement and participation is beneficial, needed and valued.			
SUMMARY: <u>Lea County Roads Advisory Committee:</u> District 1: Brad Woody (Term 01/01/2018-12/31/2019) District 1: Randy Pettigrew (Term 01/01/2019-12/31/2020) District 2: Replace Mark Gainer with _____ (Term 01/01/2018-12/31/2019) District 2: Kyle Johnston (Term 01/01/2019-12/31/2020) <p align="right">See Next Page</p>			
Requested Items Needed for Presentation Easels/Laptop/Projector/Etc.: Easel <input type="checkbox"/> Laptop <input checked="" type="checkbox"/> Projector <input checked="" type="checkbox"/> Other: _____ <small>If checked, how many.</small>		See Additional Summary Attached <input type="checkbox"/>	
SUBMITTER'S RECOMMENDATION(S): Reappoint, Replace or Confirm Appointments to the Lea County Roads Advisory Board		Submitter's Signature Department Director, Etc. 	
FINANCE REVIEW Fiscal Impact/Cost: ByPass Finance Review		Reviewed by Finance Director ByPass Finance Review Digitally signed by ByPass Finance Review Date: 2019.03.19 17:36:35 -06'00'	
LEGAL REVIEW: ByPass Legal Review (Note: Travel does not need legal review)		Reviewed by County Attorney ByPass Legal Review Digitally signed by ByPass Legal Review Date: 2019.03.19 17:36:45 -06'00'	
COUNTY MANAGER REVIEW:		Approved by County Manager to be Placed on Agenda Digitally signed by Michael P. Gallagher Date: 2019.03.19 14:00:45 -06'00'	
Item 0105 RECORDING SECRETARY'S USE ONLY ~ COMMISSION ACTION TAKEN			
Approved: _____ Resolution No. <u>19-MAR-090R</u> Continued To: _____		Denied: _____ Policy No. _____ Referred To: _____	
		Other: _____ Ordinance No. _____ Comments: _____	

Summary Form Continued...

Lea County Roads Advisory Committee (continued):

District 3: Ken Batson (Term 01/01/2018-01/02/2019)
District 3: TJ Parks (Term 01/01/2019-12/31/2020)
District 4: Vivian Flemens (Term 01/01/2018-12/31/2019)
District 4: Mark Bateman (Term 01/01/2019-12/31/2020)
District 5: James Smith (Term 01/01/2018-12/31/2019)
District 5: Cindy Shoobridge (Term 01/01/2019-12/31/2020)

STATE OF NEW MEXICO
COUNTY OF LEA
RESOLUTION NO. 19-MAR-090R

**A RESOLUTION AUTHORIZING THE LEA COUNTY BOARD OF COUNTY COMMISSIONERS
TO MAKE APPOINTMENTS TO THE LEA COUNTY ROADS ADVISORY COMMITTEE**

WHEREAS, on July 20, 1989, the Lea County Board of County Commissioners approved Resolution No. 68-89 establishing the Lea County Roads Advisory Committee; and

WHEREAS, the Lea County Roads Advisory Committee is comprised of ten members; two members from each Commission District; and

WHEREAS, there is currently a need to fill vacancies to the Lea County Roads Advisory Committee.

NOW, THEREFORE, BE IT RESOLVED by the Board of County Commissioners of Lea County, that the following individuals be appointed, re-appointed or confirmed to the Lea County Roads Advisory Committee:

Lea County Roads Advisory Committee

District 1:	Brad Woody (Term 01/01/2018-12/31/2019)
District 1:	Randy Pettigrew (Term 01/01/2019-12/31/2020)
District 2:	Replace Mark Gainer with _____ (Term 01/01/2018-12/31/2019)
District 2:	Kyle Johnston (Term 01/01/2019-12/31/2020)
District 3:	Ken Batson (Term 01/01/2018-01/02/2019)
District 3:	TJ Parks (Term 01/01/2019-12/31/2020)
District 4:	Vivian Flemens (Term 01/01/2018-12/31/2019)
District 4:	Mark Bateman (Term 01/01/2019-12/31/2020)
District 5:	James Smith (Term 01/01/2018-12/31/2019)
District 5:	Cindy Shoobridge (Term 01/01/2019-12/31/2020)

PASSED AND APPROVED on this 21st day of March, 2019, by the Lea County Board of County Commissioners in an open meeting in Lovington, New Mexico.

LEA COUNTY BOARD OF COUNTY COMMISSIONERS

Rebecca Long (District 2), Chair
Voted: Yes No Abstain

Dean Jackson (District 1), Vice Chair
Voted: Yes No Abstain

Gary G. Eidson (District 3), Member
Voted: Yes No Abstain

Jonathan Sena (District 4), Member
Voted: Yes No Abstain

Richard Don Jones (District 5), Member
Voted: Yes No Abstain

ATTEST: Keith Manes
Lea County Clerk

**APPROVED AS TO FORM AND LEGAL
SUFFICIENCY:**

By: _____
Kelli Williams, Deputy Clerk

John W. Caldwell, County Attorney

Consideration of Lea County Resolution No. 19-MAR-091R Designating a Subcommittee to Visit and Inspect the Lea County Detention Center.



NMSA 1978 Section 33-3-4 requires that the governing body of the county conducts an annual site visit to inspect the overall conditions of the jail or detention center under its jurisdiction.

NMSA 1978 Section 33-3-4 requires that following the site visit, an inspection report shall be presented at a regular meeting of the governing body.

Designated Subcommittee

1.) Commissioner _____

2.) Commissioner _____

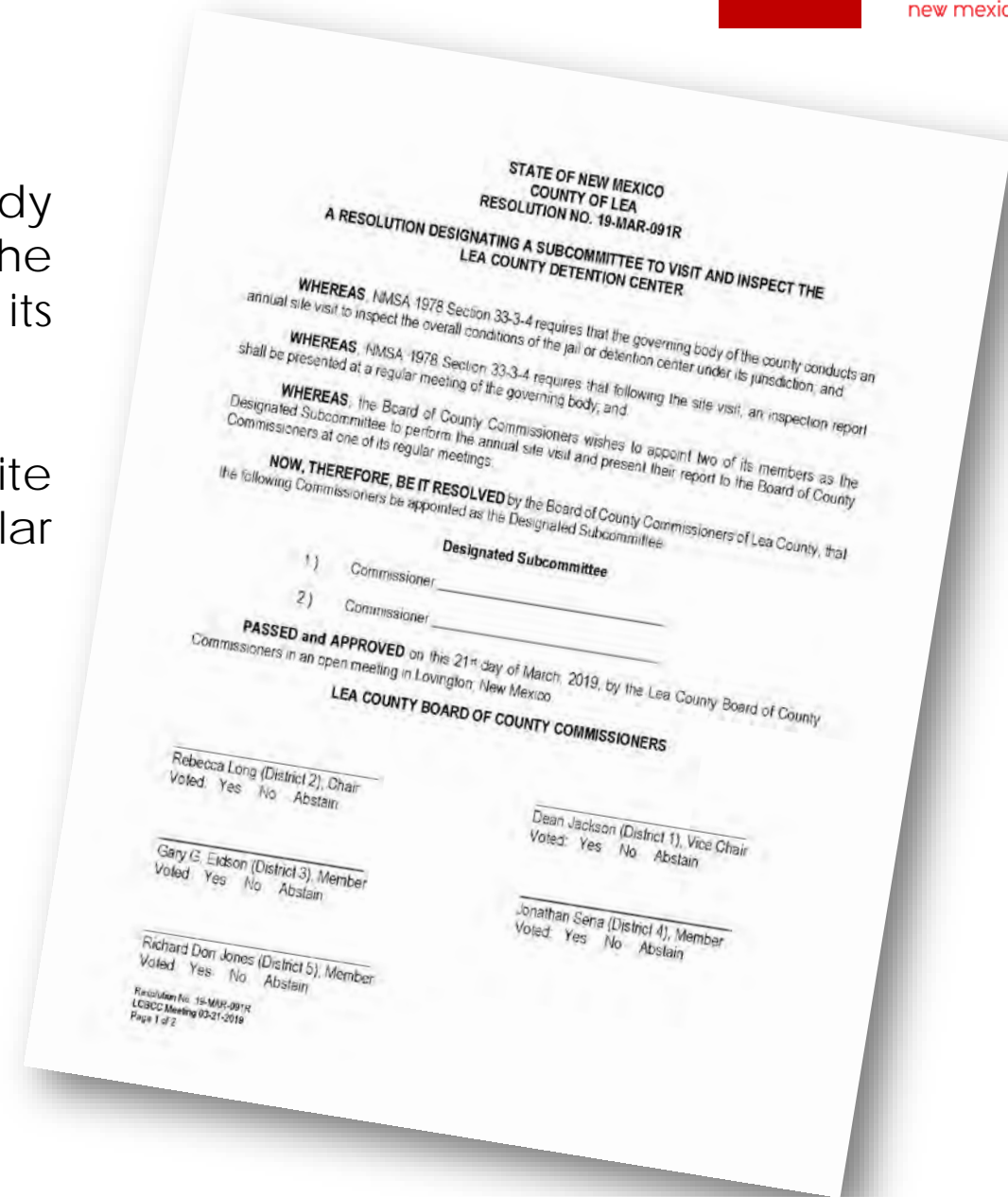



**LEA COUNTY BOARD OF COUNTY COMMISSIONERS
AGENDA ITEM SUMMARY FORM**

LCBCC Meeting Date: Thursday, March 21, 2019

Submit this summary form & all attachments to the Finance Director crow@leacounty.net & cc the Executive Coordinator ssout@leacounty.net by: **March 5, 2019**

County Manager Approval (mgallagher@leacounty.net) required for all time sensitive issues that do not meet the above deadline.

DATE SUBMITTED mm-dd-yyyy: 03/19/2019		SUBMITTED BY Name/Title/Dept: Sandra J. Stout-Brito/Executive Coordinator/Exec Dept.	
SUBJECT: Designate Subcommittee to Visit & Inspect the LCDC		ATTACHMENT(S): Resolution	
NO. OF ORIGINALS FOR SIGNATURE: 01 Resolution 00 ***Select One** 00 ***Select One**		ACTION REQUESTED: Action Item	
STRATEGIC PLAN Implementation of 5 Year Strategic Plan: Section 01: Lea County shall be results-oriented, accountable to the public, with professional and regional leadership focused on economic vitality, healthy lifestyles, quality of life and safety of the community.			
SUMMARY: NMSA 1978 Section 33-3-4 requires that the governing body of the county conducts an annual site visit to inspect the overall conditions of the jail or detention center under its jurisdiction. Following the site visit, an inspection report shall be presented at a regular meeting of the governing body. The Board of County Commissioners of Lea County wishes to appoint two of its members as the Designated Subcommittee to perform the annual site visit and present their report to the Board of County Commissioners at one of its regular meetings.			
Requested Items Needed for Presentation Easels/Laptop/Projector/Etc.:		See Additional Summary Attached <input type="checkbox"/>	
Easel <input type="checkbox"/>	Laptop <input checked="" type="checkbox"/>	Projector <input checked="" type="checkbox"/>	Other:
If checked, how many:			
SUBMITTER'S RECOMMENDATION(S): Designate 2 LCBCC to the Subcommittee		Submitter's Signature Department Director, Etc. <i>Sandra J. Stout-Brito</i>	
FINANCE REVIEW Fiscal Impact/Cost:		Reviewed by Finance Director	
LEGAL REVIEW: (Note: Travel does not need legal review)		Reviewed by County Attorney	
COUNTY MANAGER REVIEW:		Approved by County Manager to be Placed on Agenda Digitally signed by Michael P. Gallagher <i>Michael P. Gallagher</i> Date: 2019.03.19 14:00:45 -06'00'	

Item 0106 **RECORDING SECRETARY'S USE ONLY ~ COMMISSION ACTION TAKEN**

Approved: _____	Denied: _____	Other: _____
Resolution No. <u>19-MAR-091R</u>	Policy No. _____	Ordinance No. _____
Continued To: _____	Referred To: _____	Comments: _____

STATE OF NEW MEXICO
COUNTY OF LEA
RESOLUTION NO. 19-MAR-091R

**A RESOLUTION DESIGNATING A SUBCOMMITTEE TO VISIT AND INSPECT THE
LEA COUNTY DETENTION CENTER**

WHEREAS, NMSA 1978 Section 33-3-4 requires that the governing body of the county conducts an annual site visit to inspect the overall conditions of the jail or detention center under its jurisdiction; and

WHEREAS, NMSA 1978 Section 33-3-4 requires that following the site visit, an inspection report shall be presented at a regular meeting of the governing body; and

WHEREAS, the Board of County Commissioners wishes to appoint two of its members as the Designated Subcommittee to perform the annual site visit and present their report to the Board of County Commissioners at one of its regular meetings.

NOW, THEREFORE, BE IT RESOLVED by the Board of County Commissioners of Lea County, that the following Commissioners be appointed as the Designated Subcommittee:

Designated Subcommittee

- 1.) Commissioner _____
- 2.) Commissioner _____

PASSED and APPROVED on this 21st day of March, 2019, by the Lea County Board of County Commissioners in an open meeting in Lovington, New Mexico.

LEA COUNTY BOARD OF COUNTY COMMISSIONERS

Rebecca Long (District 2), Chair
Voted: Yes No Abstain

Dean Jackson (District 1), Vice Chair
Voted: Yes No Abstain

Gary G. Eidson (District 3), Member
Voted: Yes No Abstain

Jonathan Sena (District 4), Member
Voted: Yes No Abstain

Richard Don Jones (District 5), Member
Voted: Yes No Abstain

ATTEST: Keith Manes
Lea County Clerk

**APPROVED AS TO FORM AND LEGAL
SUFFICIENCY:**

By: _____
Kelli Williams, Deputy Clerk

John W. Caldwell, County Attorney



Consideration of Lea County Resolution No. 19-MAR-092R Authorizing In State Travel to Attend the 2019 New Mexico Broadband Summit "Connecting New Mexico – the Future of Broadband in Our State", March 22, 2019 in Albuquerque, New Mexico.

On 09/15/2016, the LCBCC adopted LC Resolution No. 16-SEP-188R approving Travel, Per Diem, Mileage, & Reimbursement Policies for Lea County. The LCBCC approval or ratification by majority of the vote is required for all in-state travel for the LCBCC. The County Manager has submitted the following in-state travel request(s) for approval:

- Traveler(s):** County Manager Michael Gallagher
- Department:** Manager
- Travel Dates:** March 21 - 22, 2019
- Location:** Albuquerque, NM
- Purpose:** 2019 New Mexico Broadband Summit
Connecting New Mexico
The Future of Broadband in Our State

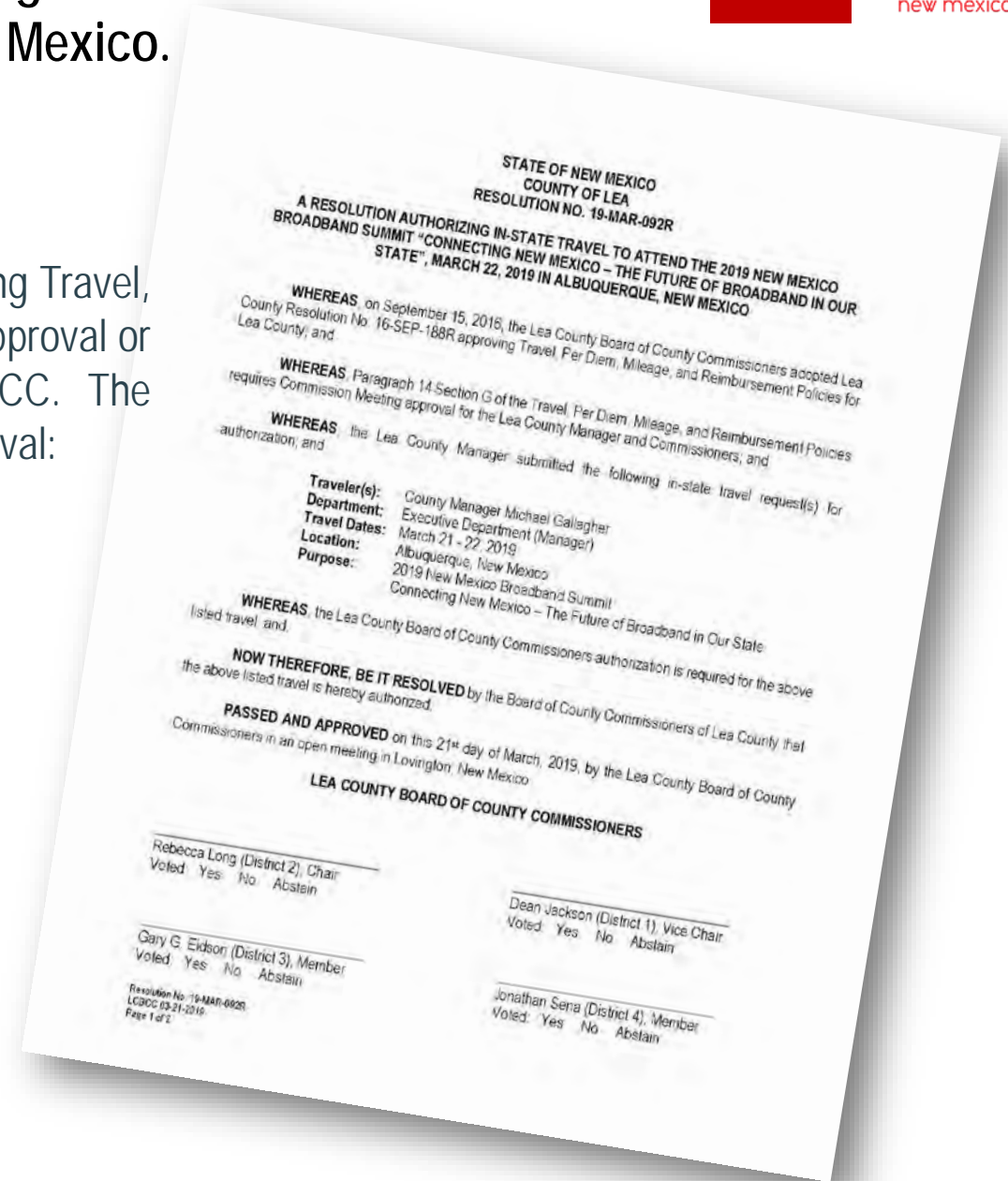



**LEA COUNTY BOARD OF COUNTY COMMISSIONERS
AGENDA ITEM SUMMARY FORM**

LCBCC Meeting Date: Thursday, March 21, 2019

Submit this summary form & all attachments to the Finance Director clow@leacounty.net & cc the Executive Coordinator sstout@leacounty.net by: **March 5, 2019**

County Manager Approval (mgallagher@leacounty.net) required for all time sensitive issues that do not meet the above deadline.

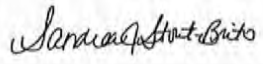
DATE SUBMITTED mm-dd-yyyy: 03/19/2019		SUBMITTED BY Name/Title/Dept: Sandrea J. Stout-Brito/Executive Coordinator/Exec Dept.	
SUBJECT: In-State Travel Authorization for LCM to Attend the 2019 NM Broadband Summit in Albuquerque, NM, March 22, 2019		ATTACHMENT(S): Resolution Travel Order	
NO. OF ORIGINALS FOR SIGNATURE: 01 Resolution 01 Travel Form 00 ***Select One**		ACTION REQUESTED: Action Item	
STRATEGIC PLAN Implementation of 5 Year Strategic Plan: Section 2.1: Collaboration & partnership with local communities, agencies and government entities is essential for success. Section 2.8: Continuous interaction with the State of New Mexico and statewide organizations is required to protect the County's interests.			
SUMMARY: On 09/15/2016, the LCBCC adopted LC Resolution No. 16-SEP-188R approving Travel, Per Diem, Mileage, & Reimbursement Policies for Lea County. The LCBCC approval or ratification by majority of the vote is required for all in-state travel for the County Manager and LCBCC. The County Manager has submitted the following in-state travel request(s) for approval: Traveler(s): LGBGG-Chair-Rebecca Long; County Manager Mike Gallagher Department: Commission; Manager Travel Dates: March 21 - 22, 2019 (Summit on 03/22) Location: Albuquerque, NM Purpose: 2019 New Mexico Broadband Summit "Connecting New Mexico - the Future of Broadband in Our State"			
Requested Items Needed for Presentation Easels/Laptop/Projector/Etc.: Easel <input type="checkbox"/> Laptop <input checked="" type="checkbox"/> Projector <input checked="" type="checkbox"/> Other: _____ <small>If checked, how many</small>			See Additional Summary Attached <input type="checkbox"/>
SUBMITTER'S RECOMMENDATION(S): Approve Travel		Submitter's Signature Department Director, Etc. 	
FINANCE REVIEW Fiscal Impact/Cost:		Reviewed by Finance Director	
LEGAL REVIEW: ByPass Legal Review <small>(Note: Travel does not need legal review)</small>		Reviewed by County Attorney ByPass Legal Review Digitally signed by ByPass Legal Review Date: 2019.03.19 17:36:45 -06'00'	
COUNTY MANAGER REVIEW: 03/19/2019: LCBCC D2 will not be able to attend.		Approved by County Manager to be Placed on Agenda Digitally signed by Michael P. Gallagher  Date: 2019.03.19 14:00:45 -06'00'	
Item 0107 RECORDING SECRETARY'S USE ONLY ~ COMMISSION ACTION TAKEN			
Approved: _____	Denied: _____	Other: _____	
Resolution No. <u>19-MAR-092R</u>	Policy No. _____	Ordinance No. _____	
Continued To: _____	Referred To: _____	Comments: _____	

STATE OF NEW MEXICO
COUNTY OF LEA
RESOLUTION NO. 19-MAR-092R

A RESOLUTION AUTHORIZING IN-STATE TRAVEL TO ATTEND THE 2019 NEW MEXICO BROADBAND SUMMIT "CONNECTING NEW MEXICO – THE FUTURE OF BROADBAND IN OUR STATE", MARCH 22, 2019 IN ALBUQUERQUE, NEW MEXICO

WHEREAS, on September 15, 2016, the Lea County Board of County Commissioners adopted Lea County Resolution No. 16-SEP-188R approving Travel, Per Diem, Mileage, and Reimbursement Policies for Lea County; and

WHEREAS, Paragraph 14 Section G of the Travel, Per Diem, Mileage, and Reimbursement Policies requires Commission Meeting approval for the Lea County Manager and Commissioners; and

WHEREAS, the Lea County Manager submitted the following in-state travel request(s) for authorization; and

Traveler(s): County Manager Michael Gallagher
Department: Executive Department (Manager)
Travel Dates: March 21 - 22, 2019
Location: Albuquerque, New Mexico
Purpose: 2019 New Mexico Broadband Summit
Connecting New Mexico – The Future of Broadband in Our State

WHEREAS, the Lea County Board of County Commissioners authorization is required for the above listed travel; and,

NOW THEREFORE, BE IT RESOLVED by the Board of County Commissioners of Lea County that the above listed travel is hereby authorized.

PASSED AND APPROVED on this 21st day of March, 2019, by the Lea County Board of County Commissioners in an open meeting in Lovington, New Mexico.

LEA COUNTY BOARD OF COUNTY COMMISSIONERS

Rebecca Long (District 2), Chair
Voted: Yes No Abstain

Dean Jackson (District 1), Vice Chair
Voted: Yes No Abstain

Gary G. Eidson (District 3), Member
Voted: Yes No Abstain

Jonathan Sena (District 4), Member
Voted: Yes No Abstain

Richard Don Jones (District 5), Member
Voted: Yes No Abstain

ATTEST: Keith Manes
Lea County Clerk

**APPROVED AS TO FORM AND LEGAL
SUFFICIENCY:**

By: _____
Kelli Williams, Deputy Clerk

John W. Caldwell, County Attorney



Consideration of Lea County Resolution No. 19-MAR-093R Authorizing In State Travel to Attend the 2019 New Mexico Counties 83rd Annual Conference, June 17 - 21, 2019 in Curry County, New Mexico.

On 09/15/2016, the LCBCC adopted LC Resolution No. 16-SEP-188R approving Travel, Per Diem, Mileage, & Reimbursement Policies for Lea County. The LCBCC approval or ratification by majority of the vote is required for all in-state travel for the LCBCC. The County Manager has submitted the following in-state travel request(s) for approval:

- Traveler(s):** LCBCC D1 Dean Jackson, Vice Chair
LCBCC D2 Rebecca Long, Chair
LCBCC D3 Gary Eidson
LCBCC D4 Jonathan Sena
LCBCC D5 Don Jones
County Manager Mike Gallagher
- Department:** Commission/Manager
- Travel Dates:** June 17 - 21, 2019
- Location:** Curry County, NM
- Purpose:** 2019 New Mexico Counties 83rd Annual Conference

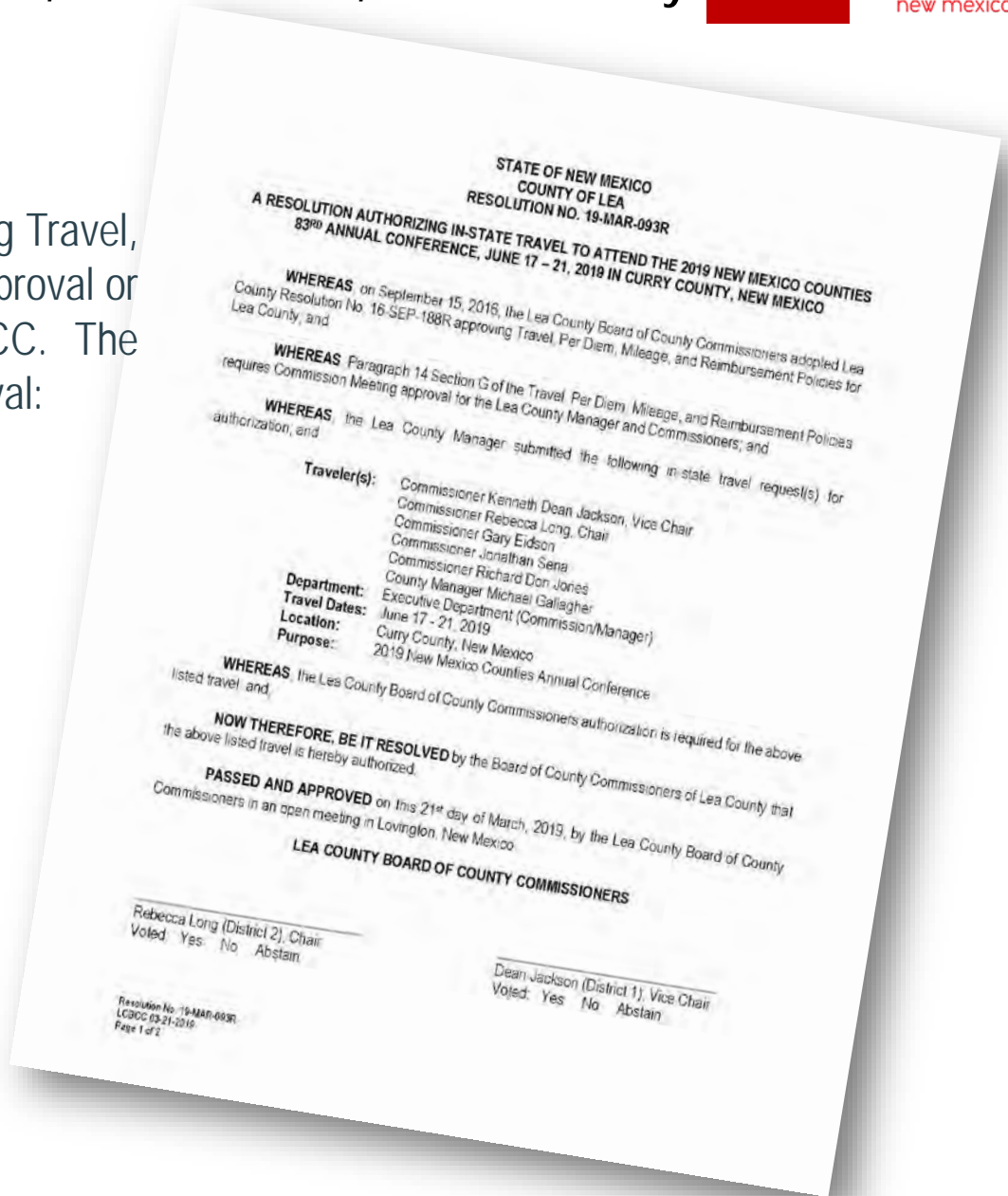

STATE OF NEW MEXICO
 COUNTY OF LEA
 RESOLUTION NO. 19-MAR-093R
 A RESOLUTION AUTHORIZING IN-STATE TRAVEL TO ATTEND THE 2019 NEW MEXICO COUNTIES 83RD ANNUAL CONFERENCE, JUNE 17 - 21, 2019 IN CURRY COUNTY, NEW MEXICO

WHEREAS on September 15, 2016, the Lea County Board of County Commissioners adopted Lea County Resolution No. 16-SEP-188R approving Travel, Per Diem, Mileage, and Reimbursement Policies for Lea County, and

WHEREAS Paragraph 14 Section G of the Travel, Per Diem, Mileage, and Reimbursement Policies requires Commission Meeting approval for the Lea County Manager and Commissioners; and

WHEREAS the Lea County Manager submitted the following in-state travel request(s) for authorization, and

Traveler(s): Commissioner Kenneth Dean Jackson, Vice Chair
 Commissioner Rebecca Long, Chair
 Commissioner Gary Eidson
 Commissioner Jonathan Sena
 Commissioner Richard Don Jones
 County Manager Michael Gallagher

Department: Executive Department (Commission/Manager)

Travel Dates: June 17 - 21, 2019

Location: Curry County, New Mexico

Purpose: 2019 New Mexico Counties Annual Conference

WHEREAS the Lea County Board of County Commissioners authorization is required for the above listed travel and,

NOW THEREFORE, BE IT RESOLVED by the Board of County Commissioners of Lea County that the above listed travel is hereby authorized.

PASSED AND APPROVED on this 21st day of March, 2019, by the Lea County Board of County Commissioners in an open meeting in Lovington, New Mexico.

LEA COUNTY BOARD OF COUNTY COMMISSIONERS

Rebecca Long (District 2), Chair
 Voted: Yes No Abstain

Dean Jackson (District 1), Vice Chair
 Voted: Yes No Abstain

Resolution No. 19-MAR-093R
 LCBCC 03-21-2019
 Page 1 of 2



**LEA COUNTY BOARD OF COUNTY COMMISSIONERS
AGENDA ITEM SUMMARY FORM**

LCBCC Meeting Date: Thursday, March 21, 2019

Submit this summary form & all attachments to the Finance Director clow@leacounty.net & cc the Executive Coordinator sstout@leacounty.net by: **March 5, 2019**

County Manager Approval (mgallagher@leacounty.net) required for all time sensitive issues that do not meet the above deadline.

DATE SUBMITTED mm-dd-yyyy: 03/19/2019		SUBMITTED BY Name/Title/Dept: Sandra J. Stout-Brito/Executive Coordinator/Exec Dept.	
SUBJECT: In-State Travel Authorization for LCBCC & LCM to Attend the 2019 NM Counties Annual Conference in Curry County, NM, June 17 - 21, 2019		ATTACHMENT(S): Resolution Travel Order	
NO. OF ORIGINALS FOR SIGNATURE: 01 Resolution 01 Travel Form 00 ***Select One**		ACTION REQUESTED: Action Item	
STRATEGIC PLAN Implementation of 5 Year Strategic Plan: Section 2.1: Collaboration & partnership with local communities, agencies and government entities is essential for success. Section 2.8: Continuous interaction with the State of New Mexico and statewide organizations is required to protect the County's interests.			
SUMMARY: On 09/15/2016, the LCBCC adopted LC Resolution No. 16-SEP-188R approving Travel, Per Diem, Mileage, & Reimbursement Polices for Lea County. The LCBCC approval or ratification by majority of the vote is required for all in-state travel for the County Manager and LCBCC. The County Manager has submitted the following in-state travel request(s) for approval: Traveler(s): LCBCC Dean Jackson, Rebecca Long, Gary Eidson, Jonathan Sena, Don Jones & County Manager Mike Gallagher Department: Commission; Manager Travel Dates: June 17 - 21, 2019 Location: Curry County, NM Purpose: 2019 New Mexico Counties 83rd Annual Conference			
Requested Items Needed for Presentation Easels/Laptop/Projector/Etc.: Easel <input type="checkbox"/> Laptop <input checked="" type="checkbox"/> Projector <input checked="" type="checkbox"/> Other: _____ <small>If checked; how many;</small>		See Additional Summary Attached <input type="checkbox"/>	
SUBMITTER'S RECOMMENDATION(S): Approve Travel		Submitter's Signature Department Director, Etc. <i>Sandra J. Stout-Brito</i>	
FINANCE REVIEW Fiscal Impact/Cost:		Reviewed by Finance Director	
LEGAL REVIEW: ByPass Legal Review (Note: Travel does not need legal review)		Reviewed by County Attorney ByPass Legal Review Digitally signed by ByPass Legal Review Date: 2019.03.19 17:36:45 -06'00'	
COUNTY MANAGER REVIEW:		Approved by County Manager to be Placed on Agenda Digitally signed by Michael P. Gallagher <i>Michael P. Gallagher</i> Date: 2019.03.19 14:00:45 -06'00'	
Item 0108 RECORDING SECRETARY'S USE ONLY ~ COMMISSION ACTION TAKEN			
Approved: _____ Resolution No. <u>19-MAR-093R</u>		Denied: _____ Policy No. _____	
Continued To: _____		Referred To: _____	
		Other: _____ Ordinance No. _____ Comments: _____	

STATE OF NEW MEXICO
COUNTY OF LEA
RESOLUTION NO. 19-MAR-093R

**A RESOLUTION AUTHORIZING IN-STATE TRAVEL TO ATTEND THE 2019 NEW MEXICO COUNTIES
83RD ANNUAL CONFERENCE, JUNE 17 – 21, 2019 IN CURRY COUNTY, NEW MEXICO**

WHEREAS, on September 15, 2016, the Lea County Board of County Commissioners adopted Lea County Resolution No. 16-SEP-188R approving Travel, Per Diem, Mileage, and Reimbursement Policies for Lea County; and

WHEREAS, Paragraph 14 Section G of the Travel, Per Diem, Mileage, and Reimbursement Policies requires Commission Meeting approval for the Lea County Manager and Commissioners; and

WHEREAS, the Lea County Manager submitted the following in-state travel request(s) for authorization; and

Traveler(s): Commissioner Kenneth Dean Jackson, Vice Chair
Commissioner Rebecca Long, Chair
Commissioner Gary Eidson
Commissioner Jonathan Sena
Commissioner Richard Don Jones
County Manager Michael Gallagher
Department: Executive Department (Commission/Manager)
Travel Dates: June 17 - 21, 2019
Location: Curry County, New Mexico
Purpose: 2019 New Mexico Counties Annual Conference

WHEREAS, the Lea County Board of County Commissioners authorization is required for the above listed travel; and,

NOW THEREFORE, BE IT RESOLVED by the Board of County Commissioners of Lea County that the above listed travel is hereby authorized.

PASSED AND APPROVED on this 21st day of March, 2019, by the Lea County Board of County Commissioners in an open meeting in Lovington, New Mexico.

LEA COUNTY BOARD OF COUNTY COMMISSIONERS

Rebecca Long (District 2), Chair
Voted: Yes No Abstain

Dean Jackson (District 1), Vice Chair
Voted: Yes No Abstain

Gary G. Eidson (District 3), Member
Voted: Yes No Abstain

Jonathan Sena (District 4), Member
Voted: Yes No Abstain

Richard Don Jones (District 5), Member
Voted: Yes No Abstain

ATTEST: Keith Manes
Lea County Clerk

**APPROVED AS TO FORM AND LEGAL
SUFFICIENCY:**

By: _____
Kelli Williams, Deputy Clerk

John W. Caldwell, County Attorney



Consideration of Lea County Resolution No. 19-MAR-094R Approving Grant No. G18SN0017A Modification No. 4 between Lea County and the Office of National Drug Control Policy Increasing Funds for the High Intensity Drug Trafficking Area (HIDTA) Region VI Awarded 01/01/2018 to 12/31/2019.

Lea County is the fiscal agent for the Region VI Drug Task Force.

For the grant period of 01/01/2018 to 12/31/2019, HIDTA was awarded a grant in the amount of \$400,261.00.

- May 29, 2018, Modification No. 01 increased the grant in the amount of \$743,343.00 for a total awarded of \$1,143,604.00.
- July 13, 2018, Modification No. 02 decreased the grant in the amount of \$1,653.00 for a total awarded of \$1,141,951.00.
- October 30, 2018, Modification No. 03 increased the grant in the amount of \$25,000.00 for a total awarded of \$1,166,951.00.
- January 23, 2019, Modification No. 04 increased the grant in the amount of \$6,408.00 for a total awarded of \$1,173,359.00

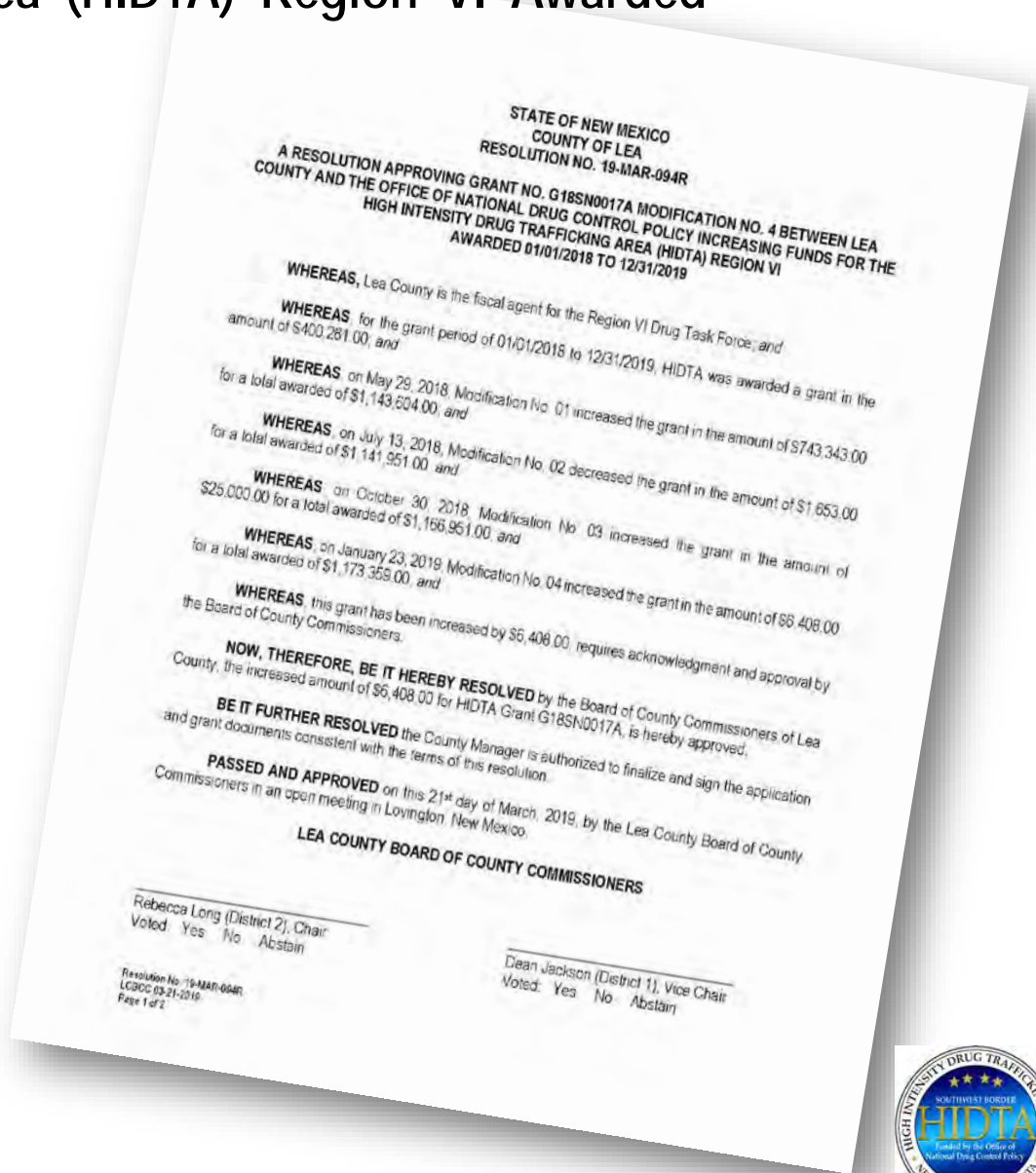



**LEA COUNTY BOARD OF COUNTY COMMISSIONERS
AGENDA ITEM SUMMARY FORM**

LCBCC Meeting Date: Thursday, March 21, 2019

Submit this summary form & all attachments to the Finance Director clow@leacounty.net & cc the Executive Coordinator sstout@leacounty.net by: March 5, 2019

County Manager Approval (mgallagher@leacounty.net) required for all time sensitive issues that do not meet the above deadline.

DATE SUBMITTED mm-dd-yyyy: 03/05/2019		SUBMITTED BY Name/Title/Dept: Wm. Robert Sullivan; Coordinator	
SUBJECT: G18SN0017A Region VI - Modification #4		ATTACHMENT(S): Modification #4	
NO. OF ORIGINALS FOR SIGNATURE: 00 Resolution 00 ***Select One** 00 ***Select One** 01 Modification		ACTION REQUESTED: Action Item	
STRATEGIC PLAN Implementation of 5 Year Strategic Plan:			
SUMMARY: This Modification 4 for G18SN0017A is to increase Region VI Drug Task Force - Pecos Valley Drug Task Force by \$6,408.00 for additional Other and Service Funds.			
Requested Items Needed for Presentation Easels/Laptop/Projector/Etc.: Easel <input type="checkbox"/> Laptop <input checked="" type="checkbox"/> Projector <input checked="" type="checkbox"/> Other: _____ <small>If checked; how many;</small>		See Additional Summary Attached <input type="checkbox"/>	
SUBMITTER'S RECOMMENDATION(S): We recommend that this Modification #4 be approved.		Submitter's Signature Department Director, Etc. Wm. Robert Sullivan <small>Digitally signed by Wm. Robert Sullivan Date: 2019.03.05 14:59:52 -0700</small>	
FINANCE REVIEW Fiscal Impact/Cost:		Reviewed by Finance Director	
LEGAL REVIEW: (Note: Travel does not need legal review)		Reviewed by County Attorney	
COUNTY MANAGER REVIEW:		Approved by County Manager to be Placed on Agenda <i>Mike Collopy</i>	
Item 0201 RECORDING SECRETARY'S USE ONLY ~ COMMISSION ACTION TAKEN			
Approved: _____	Denied: _____	Other: _____	
Resolution No. <u>19-MAR-094R</u>	Policy No. _____	Ordinance No. _____	
Continued To: _____	Referred To: _____	Comments: _____	

STATE OF NEW MEXICO
COUNTY OF LEA
RESOLUTION NO. 19-MAR-094R

A RESOLUTION APPROVING GRANT NO. G18SN0017A MODIFICATION NO. 4 BETWEEN LEA COUNTY AND THE OFFICE OF NATIONAL DRUG CONTROL POLICY INCREASING FUNDS FOR THE HIGH INTENSITY DRUG TRAFFICKING AREA (HIDTA) REGION VI AWARDED 01/01/2018 TO 12/31/2019

WHEREAS, Lea County is the fiscal agent for the Region VI Drug Task Force; *and*

WHEREAS, for the grant period of 01/01/2018 to 12/31/2019, HIDTA was awarded a grant in the amount of \$400,261.00; *and*

WHEREAS, on May 29, 2018, Modification No. 01 increased the grant in the amount of \$743,343.00 for a total awarded of \$1,143,604.00; *and*

WHEREAS, on July 13, 2018, Modification No. 02 decreased the grant in the amount of \$1,653.00 for a total awarded of \$1,141,951.00; *and*

WHEREAS, on October 30, 2018, Modification No. 03 increased the grant in the amount of \$25,000.00 for a total awarded of \$1,166,951.00; *and*

WHEREAS, on January 23, 2019, Modification No. 04 increased the grant in the amount of \$6,408.00 for a total awarded of \$1,173,359.00; *and*

WHEREAS, this grant has been increased by \$6,408.00, requires acknowledgment and approval by the Board of County Commissioners.

NOW, THEREFORE, BE IT HEREBY RESOLVED by the Board of County Commissioners of Lea County, the increased amount of \$6,408.00 for HIDTA Grant G18SN0017A, is hereby approved.

BE IT FURTHER RESOLVED the County Manager is authorized to finalize and sign the application and grant documents consistent with the terms of this resolution.

PASSED AND APPROVED on this 21st day of March, 2019, by the Lea County Board of County Commissioners in an open meeting in Lovington, New Mexico.

LEA COUNTY BOARD OF COUNTY COMMISSIONERS

Rebecca Long (District 2), Chair
Voted: Yes No Abstain

Dean Jackson (District 1), Vice Chair
Voted: Yes No Abstain

Gary G. Eidson (District 3), Member
Voted: Yes No Abstain

Jonathan Sena (District 4), Member
Voted: Yes No Abstain

Richard Don Jones (District 5), Member
Voted: Yes No Abstain

ATTEST: Keith Manes
Lea County Clerk

**APPROVED AS TO FORM AND LEGAL
SUFFICIENCY:**

By: _____
Kelli Williams, Deputy Clerk

John W. Caldwell, County Attorney



Southwest Border HIDTA - New Mexico

High Intensity Drug Trafficking Areas Program

2450 Lakeside Dr. Bldg. A, Las Cruces, NM 88007
PH (575) 541-7501 Fax (575) 541-7510

February 19, 2019

County Manager Michael Gallagher
Lea County
100 North Main
Lovington, NM 88260

Dear Mr. Gallagher:

High Intensity Drug Trafficking (HIDTA) FY 18 funds have increased by \$6,408.00 as indicated on Modification 4 for the Region VI Drug Task Force-Pecos Valley Initiative. The enclosed grant award modification should be completed and **returned to the NM HIDTA Director's Office** as soon as possible.

Detailed information is provided in a letter to you from Michael K. Gottlieb, National HIDTA Director. *In his letters he does ask that you send the signed Award Modifications to Miami; however I am asking that you return this paperwork to our office.* We will forward this information to the Miami Assistance Center to ensure that we have the same records.

If you have any questions, please contact Sandra A. Russell, Finance Director at (575) 541-7503.

Sincerely,

A handwritten signature in blue ink, appearing to read "Mark Payne".

Mark Payne
Director, Southwest Border HIDTA-New Mexico Region

Attachments

MP:sar



January 23, 2019

County Manager Michael Gallagher
Lea County
100 N Main
Lovington, NM 88260-4030

Dear Mr. Gallagher:

Grant number G18SN0017A has been increased and now totals \$1,173,359.00.

The original of Modification 4 is enclosed. If you accept this Modification, sign the Modification and return a copy to the Assistance Center in Miami. Keep the original Modification for your file.

All terms and conditions of the original award apply to the Modification. If you have any questions pertaining to this grant award, please contact Jayme Delano at (202) 395-6794.

Sincerely,

A handwritten signature in cursive script that reads "Michael K. Gottlieb".

Michael K. Gottlieb
Associate Director

Enclosures

Executive Office of the President Office of National Drug Control Policy		AWARD Grant	Page 1 of 1
1. Recipient Name and Address County Manager Michael Gallagher Lea County 100 N Main Lovington, NM 88260-4030		4. Award Number: G18SN0017A	
		5. Grant Period: From 01/01/2018 to 12/31/2019	
2. Total Amount of the Federal Funds Obligated: \$1,173,359	6. Federal Award Date: 1/23/2019	7. Action Initial <input checked="" type="checkbox"/> Supplemental	
2A. Budget Approved by the Federal Awarding Agency \$1,173,359	8. Supplement Number 4		
3. CFDA Name and Number: <i>High Intensity Drug Trafficking Areas Program - 95.001</i>	9. Previous Award Amount: \$1,166,951.00		
3A. Project Description <i>High Intensity Drug Trafficking Areas (HIDTA) Program</i>	10. Amount of Federal Funds Obligated by this Action: \$6,408.00		
	11. Total Amount of Federal Award: \$1,173,359.00		
12. The above grant is approved subject to such conditions or limitation as are set forth in the original Grant.			
13. Statutory Authority for Grant: Public Law:115-141			
AGENCY APPROVAL		RECIPIENT ACCEPTANCE	
14. Typed Name and Title of Approving Official Michael K. Gottlieb Associate Director Office of National Drug Control Policy		15. Typed Name and Title of Authorized Official Michael Gallagher Lea County	
16. Signature of Approving ONDCP Official <i>Michael K. Gottlieb</i>		17. Signature of Authorized Recipient/Date	
AGENCY USE ONLY			
18. Accounting Classification Code DUNS: 010485308 EIN: 1856000226A2		19. HIDTA AWARD OND1070DB1819XX OND6113 OND2000000000 OC 410001 JID: 61832	

Initiative Cash by HIDTA

FY 2018

HIDTA	Agency Name	Initiative	Cash	Type	Grant
SWB - New Mexico	Lea County	BI - Region VI Drug Task Force - Chaves County	25,000.00	Investigation	G18SN0017A
		Region VI Drug Task Force - Administration	106,015.00	Investigation	G18SN0017A
		Region VI Drug Task Force - Chaves County	136,681.00	Investigation	G18SN0017A
		Region VI Drug Task Force - Lea County	399,211.00	Investigation	G18SN0017A
		Region VI Drug Task Force - Lincoln County	134,546.00	Investigation	G18SN0017A
		Region VI Drug Task Force - Pecos Valley	371,906.00	Investigation	G18SN0017A
	Agency Total : Lea County		1,173,359.00		
Total			1,173,359.00		

Budget Detail

2018 - SWB - New Mexico

Initiative - Region VI Drug Task Force - Pecos Valley

Investigation

Award Recipient - Lea County (G18SN0017A)

Resource Recipient - Eddy County

Indirect Cost: 0.0%

Current Budget (net of reprogrammed funds)		\$6,408.00
Services	Quantity	Amount
Services		\$908.00
Total Services		\$908.00
Other	Quantity	Amount
Other		\$5,500.00
Total Other		\$5,500.00
Total Budget		\$6,408.00



Consideration of Lea County Resolution No. 19-MAR-095R Approving Grant No. G18SN0017A Modification No. 5 between Lea County and the Office of National Drug Control Policy Increasing Funds for the High Intensity Drug Trafficking Area (HIDTA) Region VI Awarded 01/01/2018 to 12/31/2019.

Lea County is the fiscal agent for the Region VI Drug Task Force.

For the grant period of 01/01/2018 to 12/31/2019, HIDTA was awarded a grant in the amount of \$400,261.00.

- May 29, 2018, Modification No. 01 increased the grant in the amount of \$743,343.00 for a total awarded of \$1,143,604.00.
- July 13, 2018, Modification No. 02 decreased the grant in the amount of \$1,653.00 for a total awarded of \$1,141,951.00.
- October 30, 2018, Modification No. 03 increased the grant in the amount of \$25,000.00 for a total awarded of \$1,166,951.00.
- January 23, 2019, Modification No. 04 increased the grant in the amount of \$6,408.00 for a total awarded of \$1,173,359.00.
- February 27, 2019, Modification No. 05 increased the grant in the amount of \$3,000.00 for a total awarded of \$1,176,359.00.

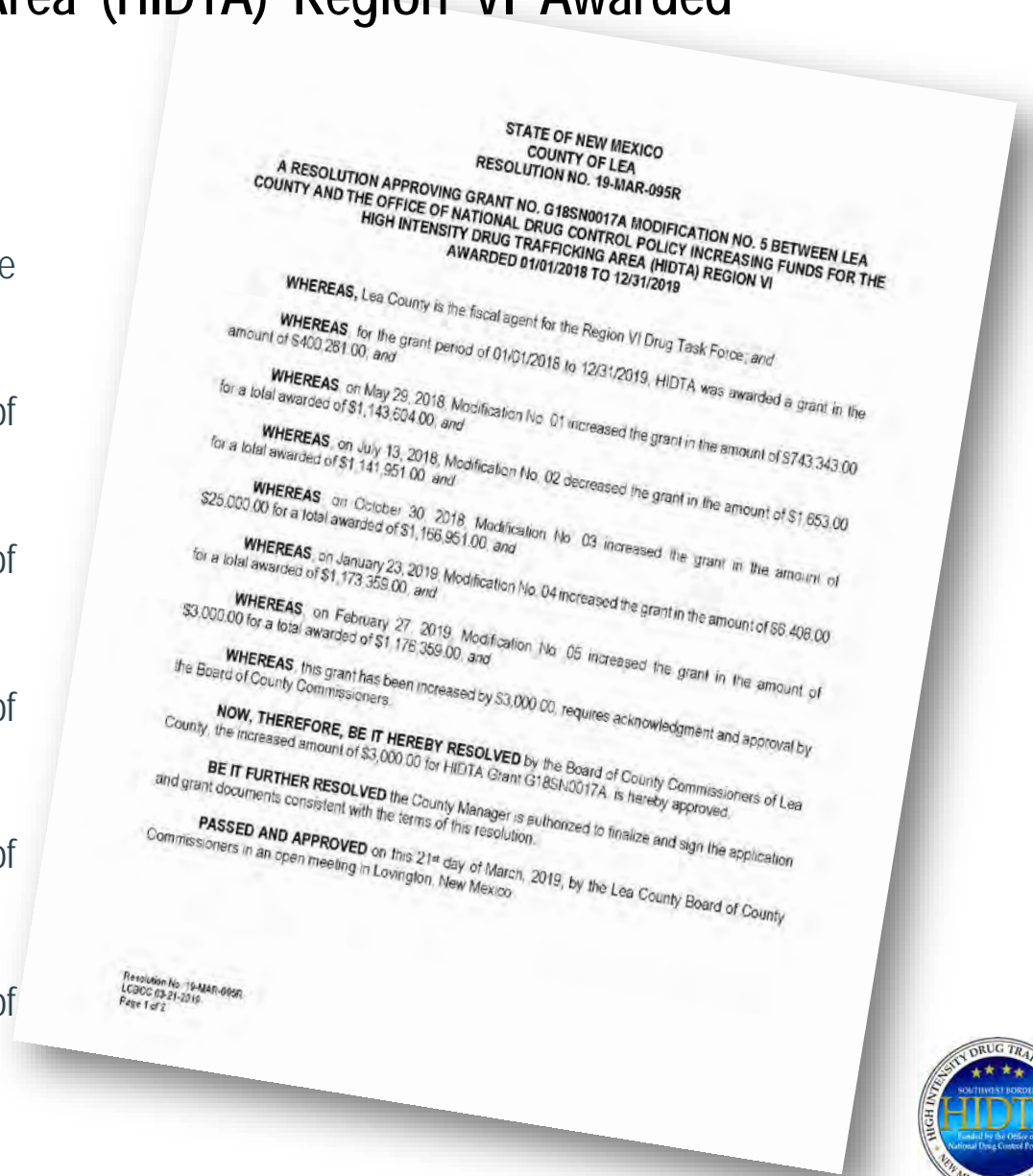



**LEA COUNTY BOARD OF COUNTY COMMISSIONERS
AGENDA ITEM SUMMARY FORM**

LCBCC Meeting Date: Thursday, March 21, 2019

Submit this summary form & all attachments to the Finance Director clow@leacounty.net & cc the Executive Coordinator [sstout@leacounty.net](mailto:ss Stout@leacounty.net) by: March 5, 2019

County Manager Approval (mgallagher@leacounty.net) required for all time sensitive issues that do not meet the above deadline.

DATE SUBMITTED mm-dd-yyyy: 03/07/2019		SUBMITTED BY Name/Title/Dept: Wm Robert Sullivan; Coordinator	
SUBJECT: G18SN0017A Region VI - Modification #5		ATTACHMENT(S): Modification #5	
NO. OF ORIGINALS FOR SIGNATURE: 00 Resolution 00 ***Select One** 00 ***Select One** 01 Modification		ACTION REQUESTED: Action Item	
STRATEGIC PLAN Implementation of 5 Year Strategic Plan:			
SUMMARY: This Modification 5 for G18SN0017A is to increase Region VI Drug Task Force - Lincoln County NEU by \$3,000.00 for additional Overtime Funds.			
Requested Items Needed for Presentation Easels/Laptop/Projector/Etc.: Easel <input type="checkbox"/> Laptop <input checked="" type="checkbox"/> Projector <input checked="" type="checkbox"/> Other: _____ <small>If checked; how many:</small>		See Additional Summary Attached <input type="checkbox"/>	
SUBMITTER'S RECOMMENDATION(S): We recommend that this Modification #5 be approved		Submitter's Signature Department Director, Etc. Wm. Robert Sullivan <small>Digitally signed by Wm. Robert Sullivan Date: 2019.03.07 16:31:13 -0700</small>	
FINANCE REVIEW Fiscal Impact/Cost:		Reviewed by Finance Director	
LEGAL REVIEW: (Note: Travel does not need legal review)		Reviewed by County Attorney	
COUNTY MANAGER REVIEW:		Approved by County Manager to be Placed on Agenda <i>Mike Collopy</i>	
Item 0202 RECORDING SECRETARY'S USE ONLY ~ COMMISSION ACTION TAKEN			
Approved: _____ Resolution No. <u>19-MAR-095R</u>		Denied: _____ Policy No. _____	
Continued To: _____		Referred To: _____ Other: _____ Ordinance No. _____ Comments: _____	

STATE OF NEW MEXICO
COUNTY OF LEA
RESOLUTION NO. 19-MAR-095R

A RESOLUTION APPROVING GRANT NO. G18SN0017A MODIFICATION NO. 5 BETWEEN LEA
COUNTY AND THE OFFICE OF NATIONAL DRUG CONTROL POLICY INCREASING FUNDS FOR THE
HIGH INTENSITY DRUG TRAFFICKING AREA (HIDTA) REGION VI
AWARDED 01/01/2018 TO 12/31/2019

WHEREAS, Lea County is the fiscal agent for the Region VI Drug Task Force; *and*

WHEREAS, for the grant period of 01/01/2018 to 12/31/2019, HIDTA was awarded a grant in the amount of \$400,261.00; *and*

WHEREAS, on May 29, 2018, Modification No. 01 increased the grant in the amount of \$743,343.00 for a total awarded of \$1,143,604.00; *and*

WHEREAS, on July 13, 2018, Modification No. 02 decreased the grant in the amount of \$1,653.00 for a total awarded of \$1,141,951.00; *and*

WHEREAS, on October 30, 2018, Modification No. 03 increased the grant in the amount of \$25,000.00 for a total awarded of \$1,166,951.00; *and*

WHEREAS, on January 23, 2019, Modification No. 04 increased the grant in the amount of \$6,408.00 for a total awarded of \$1,173,359.00; *and*

WHEREAS, on February 27, 2019, Modification No. 05 increased the grant in the amount of \$3,000.00 for a total awarded of \$1,176,359.00; *and*

WHEREAS, this grant has been increased by \$3,000.00, requires acknowledgment and approval by the Board of County Commissioners.

NOW, THEREFORE, BE IT HEREBY RESOLVED by the Board of County Commissioners of Lea County, the increased amount of \$3,000.00 for HIDTA Grant G18SN0017A, is hereby approved.

BE IT FURTHER RESOLVED the County Manager is authorized to finalize and sign the application and grant documents consistent with the terms of this resolution.

PASSED AND APPROVED on this 21st day of March, 2019, by the Lea County Board of County Commissioners in an open meeting in Lovington, New Mexico.

LEA COUNTY BOARD OF COUNTY COMMISSIONERS

Rebecca Long (District 2), Chair
Voted: Yes No Abstain

Dean Jackson (District 1), Vice Chair
Voted: Yes No Abstain

Gary G. Eidson (District 3), Member
Voted: Yes No Abstain

Jonathan Sena (District 4), Member
Voted: Yes No Abstain

Richard Don Jones (District 5), Member
Voted: Yes No Abstain

ATTEST: Keith Manes
Lea County Clerk

**APPROVED AS TO FORM AND LEGAL
SUFFICIENCY:**

By: _____
Kelli Williams, Deputy Clerk

John W. Caldwell, County Attorney



Southwest Border HIDTA - New Mexico

High Intensity Drug Trafficking Areas Program

2450 Lakeside Dr. Bldg. A, Las Cruces, NM 88007
PH (575) 541-7501 Fax (575) 541-7510

March 7, 2019

County Manager Michael Gallagher
Lea County
100 North Main
Lovington, NM 88260

Dear Mr. Gallagher:

High Intensity Drug Trafficking (HIDTA) FY 18 funds have increased by \$3,000.00 as indicated on Modification 5 for the Region VI Drug Task Force-Lincoln County Initiative. The enclosed grant award modification should be completed and **returned to the NM HIDTA Director's Office** as soon as possible.

Detailed information is provided in a letter to you from Michael K. Gottlieb, National HIDTA Director. *In his letters he does ask that you send the signed Award Modifications to Miami; however I am asking that you return this paperwork to our office.* We will forward this information to the Miami Assistance Center to ensure that we have the same records.

If you have any questions, please contact Sandra A. Russell, Finance Director at (575) 541-7503.

Sincerely,

A handwritten signature in blue ink, appearing to read "M. Payne".

Mark Payne
Director, Southwest Border HIDTA-New Mexico Region

Attachments

MP:sar



February 27, 2019

County Manager Michael Gallagher
Lea County
100 N Main
Lovington, NM 88260-4030

Dear Mr. Gallagher:

Grant number G18SN0017A has been increased and now totals \$1,176,359.00.

The original of Modification 5 is enclosed. If you accept this Modification, sign the Modification and return a copy to the Assistance Center in Miami. Keep the original Modification for your file.

All terms and conditions of the original award apply to the Modification. If you have any questions pertaining to this grant award, please contact Jayme Delano at (202) 395-6794.

Sincerely,

A handwritten signature in cursive script that reads "Shannon J. Kelly".

Shannon Kelly
National HIDTA Director

Enclosures

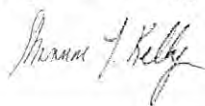
Executive Office of the President Office of National Drug Control Policy		AWARD Grant	Page 1 of 1
1. Recipient Name and Address County Manager Michael Gallagher Lea County 100 N Main Lovington, NM 88260-4030		4. Award Number: G18SN0017A	
		5. Grant Period: From 01/01/2018 to 12/31/2019	
2. Total Amount of the Federal Funds Obligated: \$1,176,359	6. Federal Award Date: 2/27/2019	7. Action Initial <input type="checkbox"/> Supplemental	
2A. Budget Approved by the Federal Awarding Agency \$1,176,359	8. Supplement Number 5		
3. CFDA Name and Number: <i>High Intensity Drug Trafficking Areas Program - 95.001</i>	9. Previous Award Amount: \$1,173,359.00		
3A. Project Description <i>High Intensity Drug Trafficking Areas (HIDTA) Program</i>	10. Amount of Federal Funds Obligated by this Action: \$3,000.00		
	11. Total Amount of Federal Award: \$1,176,359.00		
12. The above grant is approved subject to such conditions or limitation as are set forth in the original Grant.			
13. Statutory Authority for Grant: Public Law:115-141			
AGENCY APPROVAL		RECIPIENT ACCEPTANCE	
14. Typed Name and Title of Approving Official Shannon Kelly National HIDTA Director Office of National Drug Control Policy		15. Typed Name and Title of Authorized Official Michael Gallagher Lea County	
16. Signature of Approving ONDCP Official 		17. Signature of Authorized Recipient/Date	
AGENCY USE ONLY			
18. Accounting Classification Code DUNS: 010485308 EIN: 1856000226A2		19. HIDTA AWARD OND1070DB1819XX OND6113 OND2000000000 OC 410001 JID: 62493	

Budget Detail

2018 - SWB - New Mexico

Initiative - Region VI Drug Task Force - Lincoln County

Investigation

Award Recipient - Lea County (G18SN0017A)

Resource Recipient - City of Alamogordo

Indirect Cost: 0.0%

Current Budget (net of reprogrammed funds) **\$3,000.00**

Overtime	Quantity	Amount
Overtime		\$1,500.00
Total Overtime		\$1,500.00
Total Budget		\$1,500.00

Budget Detail

2018 - SWB - New Mexico

Initiative - Region VI Drug Task Force - Lincoln County

Investigation

Award Recipient - Lea County (G18SN0017A)

Resource Recipient - Otero County

Current Budget (net of approved transactions) ***\$1,500.00***

Overtime	Quantity	Amount
-----------------	-----------------	---------------

Overtime		\$1,500.00
----------	--	------------

Total Overtime		\$1,500.00
-----------------------	--	-------------------

Total Budget		\$1,500.00
---------------------	--	-------------------

Consideration of Lea County Resolution No. 19-MAR-096R Approving a Memorandum of Understanding - Air Traffic Control Tower Operations Agreement between Lea County and the Federal Aviation Administration (FAA) for the Lea County Regional Airport.

1



The Federal Aviation Administration (FAA) is standardizing its operating agreements with local sponsors throughout the county.

The Federal Aviation Administration (FAA) and Lea County operate the air traffic control tower located at the Lea County Regional Airport near Hobbs, NM.

The tower is operated by a third party contractor (RVA Aviation) hired by the FAA through the Contract Towers Program. Lea County is also member of the FCT Cost Share Tower Program. Due to the commercial airline service, the current FAA Reauthorization Act of 2018 caps the sponsors cost at 20%.

The HOB Tower is one of six ATCT in New Mexico. The ATCT tower is responsible for controlling air and ground traffic within the Class D airspace, maintaining FAA owned facilities and equipment, collecting hourly and daily operations, and providing weather to aviators and ground personnel.

Within the agreement, FAA will continue to provide these services. Lea County will continue to be responsible for supplying the Air Traffic Control Tower, maintain all non-FAA owned tower equipment, and all utilities as the county does at this time.

None of the responsibilities of the FAA or the Airport Sponsor (Lea County) change in this agreement.





**LEA COUNTY BOARD OF COUNTY COMMISSIONERS
AGENDA ITEM SUMMARY FORM**

LCBCC Meeting Date: Thursday, March 21, 2019

Submit this summary form & all attachments to the Finance Director clow@leacounty.net & cc the Executive Coordinator sstout@leacounty.net by: **March 5, 2019**

County Manager Approval (mgallagher@leacounty.net) required for all time sensitive issues that do not meet the above deadline.

DATE SUBMITTED mm-dd-yyyy: 03/15/2019		SUBMITTED BY Name/Title/Dept: Corey Needham/ Assistant County Manager	
SUBJECT: - FAA - Air Traffic Control Tower Operations Agreement		ATTACHMENT(S): ATC Tower Operations Agreement, TOA Cover Letter, NDA Cover V1, DOT-FAA NDA for SSI-SUI, Resolution, Power Point	
NO. OF ORIGINALS FOR SIGNATURE: 01 Resolution 01 Agreement 00 ***Select One**		ACTION REQUESTED: Action Item	
STRATEGIC PLAN Implementation of 5 Year Strategic Plan: Airports that are maintained and improved with new facilities (goal: increase capacity for changing commercial aircraft)			
SUMMARY: The Federal Aviation Administration (FAA) is standardizing its operating agreements with local sponsors throughout the county. The Federal Aviation Administration (FAA) and Lea County operate the air traffic control tower located at the Lea County Regional Airport near Hobbs, NM. The tower is operated by a third party contractor (RVA Aviation) hired by the FAA through the Contract Towers Program. Lea County is also member of the FCT Cost Share Tower Program. Due to the commercial airline service, the current FAA Reauthorization Act of 2018 caps the sponsors cost at 20%. The HOB Tower is one of six ATCT in New Mexico. The ATCT tower is responsible for controlling air and ground traffic within the Class D airspace,			
Requested Items Needed for Presentation Easels/Laptop/Projector/Etc.: Easel <input type="checkbox"/> Laptop <input checked="" type="checkbox"/> Projector <input checked="" type="checkbox"/> Other: _____ <small>If checked, how many:</small>		See Additional Summary Attached <input checked="" type="checkbox"/>	
SUBMITTER'S RECOMMENDATION(S): Staff recommends LCBC accept the agreement as proposed and allow the chairman and airport manager to sign where appropriate.		Submitter's Signature Department Director, Etc. Corey Needham <small>Digitally signed by Corey Needham DN: cn=Corey Needham, o=Lea County, ou=Lea County, email=coreyneedham@leacounty.net, c=US Date: 2019.03.15 17:33:56 -0600</small>	
FINANCE REVIEW Fiscal Impact/Cost: The financial impact to Lea County will be the costs of maintaining the control tower at Lea Regional (utilities, maintenance, etc.). Funds are budgeted in the 454 - Lea Regional Airport.		Reviewed by Finance Director Henry C Low Jr <small>Digitally signed by Henry C Low Jr Date: 2019.03.16 12:20:33 -06'00'</small>	
LEGAL REVIEW: (Note: Travel does not need legal review)		Reviewed by County Attorney	
COUNTY MANAGER REVIEW:		Approved by County Manager to be Placed on Agenda <i>Michael P. Gallagher</i> <small>Digitally signed by Michael P. Gallagher Date: 2019.03.20 12:21:22 -06'00'</small>	
Item 0203 RECORDING SECRETARY'S USE ONLY ~ COMMISSION ACTION TAKEN			
Approved: _____ Resolution No. <u>19-MAR-096R</u>		Denied: _____ Policy No. _____	
Continued To: _____		Other: _____ Ordinance No. _____ Comments: _____	

Summary Form Continued...

maintaining FAA owned facilities and equipment, collecting hourly and daily operations, and providing weather to aviators and ground personnel.

Within the agreement, FAA will continue to provide these services. Lea County will continue to be responsible for supplying the Air Traffic Control Tower, maintain all non-FAA owned tower equipment, and all utilities as the county does at this time.

None of the responsibilities of the FAA or the Airport Sponsor (Lea County) change in this agreement.

STATE OF NEW MEXICO
COUNTY OF LEA
RESOLUTION NO. 19-MAR-096R

**A RESOLUTION APPROVING A MEMORANDUM OF UNDERSTANDING – AIR TRAFFIC CONTROL
TOWER OPERATIONS AGREEMENT BETWEEN LEA COUNTY AND THE FEDERAL AVIATION
ADMINISTRATION (FAA) FOR THE LEA COUNTY REGIONAL AIRPORT**

WHEREAS, the Federal Aviation Administration (FAA) is standardizing its operating agreements with local sponsors throughout the county; *and*

WHEREAS, the FAA and Lea County operate the air traffic control tower located at the Lea County Regional Airport near Hobbs, NM; *and*

WHEREAS, Lea County is also member of the FCT Cost Share Tower Program. Due to the commercial airline service, the current FAA Reauthorization Act of 2018 caps the sponsors cost at 20%; *and*

WHEREAS, within the agreement, FAA will continue to provide these services. Lea County will continue to be responsible for supplying the Air Traffic Control Tower, maintain all non-FAA owned tower equipment, and all utilities as the county does at this time. None of the responsibilities of the FAA or the Airport Sponsor (Lea County) change in this agreement.

NOW, THEREFORE, BE IT HEREBY RESOLVED by the Board of County Commissioners of Lea County, that the Memorandum of Understanding Air Traffic Control Tower Operations Agreement between Lea County and the FAA is hereby approved.

BE IT FURTHER RESOLVED that the Commission Chair may finalize and sign any agreements consistent with the terms of this resolution.

PASSED and APPROVED on this 21st day of March, 2019, by the Lea County Board of County Commissioners in an open meeting in Lovington, New Mexico.

LEA COUNTY BOARD OF COUNTY COMMISSIONERS

Rebecca Long (District 2), Chair
Voted: Yes No Abstain

Dean Jackson (District 1), Vice Chair
Voted: Yes No Abstain

Gary G. Eidson (District 3), Member
Voted: Yes No Abstain

Jonathan Sena (District 4), Member
Voted: Yes No Abstain

Richard Don Jones (District 5), Member
Voted: Yes No Abstain

ATTEST: Keith Manes
Lea County Clerk

**APPROVED AS TO FORM AND LEGAL
SUFFICIENCY:**

By: _____
Kelli Williams, Deputy Clerk

John W. Caldwell, County Attorney

**AIR TRAFFIC CONTROL TOWER OPERATIONS AGREEMENT BETWEEN
FEDERAL AVIATION ADMINISTRATION (FAA)
AND
LEA COUNTY GOVERNMENT**

I. PARTIES

This Air Traffic Control Tower Operations Agreement (TOA) (hereinafter "Agreement"), is hereby made and entered into this _____ day of _____, 20____ by and between the Federal Aviation Administration ("FAA") and the Lea County ("Airport Sponsor") (collectively known as the "Parties").

II. SCOPE

The purpose of this Memorandum of Understanding (MOU) between the FAA and the Airport Sponsor is to set forth the terms under which the FAA will provide air traffic control (ATC) services to the Airport Sponsor at *Lea County Regional Airport* ("Airport"), located near Hobbs, NM. This Agreement replaces and supersedes any prior TOA signed by the parties.

III. ROLES AND RESPONSIBILITIES OF THE PARTIES

A. Roles and responsibilities of the FAA.

The FAA shall provide ATC services at the Airport, by way of a contractual agreement between the FAA and an air traffic control services provider of the FAA's choice, in accordance with standards established by the FAA, subject to the availability of funds.

The tower hours of operation will be 0600 to 1800.

The FAA reserves the right to adjust those hours in accordance with applicable FAA standards, regulations and policy.

The FAA/ATC contractor will collect hourly and daily traffic count data during tower operating hours.

The FAA will maintain all FAA-owned equipment installed in the tower.

The FAA will conduct annual occupational safety and health inspections, for any FCT that is an FAA employee's duty station.

The FAA will conduct periodic security inspections based upon the criteria identified in FAA Order 1600.69, as may be amended. Relevant portions of the Order will be provided to Airport Sponsors. (A Signed Non-Disclosure Agreement (NDA) will be required to receive a copy of the Order.)

B. Roles and responsibilities of the Airport Sponsor.

The Airport Sponsor shall provide and maintain, at no expense to the FAA, an Airport Traffic Control Tower (ATCT) that meets all applicable state and local codes, standards and regulations.

In the absence of applicable state and local codes, standards, and regulations, the Airport Sponsor shall provide and maintain, at no expense to the FAA, an Airport Traffic Control Tower (ATCT) that meets all applicable Federal codes, standards and regulations.

The Airport Sponsor shall provide, maintain, and replace, at no expense to the FAA, all non-FAA-owned tower equipment required by the Minimum Equipment and Facilities List (MEL).

The Airport Sponsor shall provide and continually maintain all utilities and services, including but not limited to: heating, air conditioning, electrical, water, gas and sewer. The Airport Sponsor shall maintain janitorial services (to include washing tower cab windows and shades, interior and exterior, when necessary).

The Airport Sponsor shall be responsible for the proper and continued functioning of all equipment that the FAA determines is necessary for ATC operations, including that which cannot be placed in operation or otherwise controlled from the ATCT building or that is not otherwise within the control of the FAA, its agents, representatives or contractors. Examples include, but are not limited to airport lighting, windsock, obstruction lights, rotating beacon, etc.

The Airport Sponsor is responsible for ensuring security and controlled access to the tower is established and maintained in accordance with FAA Order 1600.69, as may be amended. Relevant portions of the Order will be provided to Airport Sponsors. (A Signed NDA will be required to receive a copy of the Order.)

The Airport Sponsor agrees to enter into a Letter of Agreement (LOA) with the ATC service provider's local representative specifically for the purpose of providing an airport point of contact and procedures to follow to ensure a timely response to requests concerning equipment, security or building problems.

In accordance with FAA Order JO 7210.3, as revised, other Letters of Agreement may be necessary for topics such as airport emergency service, control of vehicular traffic on airport movement areas, operation of airport lighting, local procedures and reporting airport conditions. However, the terms and conditions

set forth in this Agreement or the FAA Contract Tower (FCT) contract cannot be waived or superseded by such local agreements.

IV. BENEFIT/COST RATIOS CONSIDERATION

Current procedures require FAA to recalculate benefit/cost ratios periodically to determine the percentage of funds for which the FAA and the airport are responsible. The FAA currently provides full funding for sites with a benefit/cost ratio of 1.0 or greater. Fully funded sites whose benefit/cost ratio decreases to less than 1.0 will be offered the opportunity to participate in the FCT Cost Share Program.

V. SUPPLEMENTAL HOURS

If the Airport Sponsor requests ATC services outside of FAA approved tower hours of operation, the provision of such additional services shall be at the expense of the Airport Sponsor. These supplemental hours of operation may be achieved through an agreement with the air traffic control services provider, supplemental agreement with the FAA, or by other authorized means.

VI. POINTS OF CONTACT

Airport Sponsor

Corey Needham
Assistant County Manager/ Airports Director
(575) 391-2934
cneedham@leacounty.net

FCT Program Implementation Manager

FCT Program Manager

VII. CHANGES AND/OR MODIFICATIONS

Changes and/or modifications to this Agreement shall be in writing and signed by both parties. The modification shall cite the subject Agreement, and shall state the exact nature of the modification. No oral statement by any person shall be interpreted as modifying or otherwise affecting the terms of this Agreement.

VIII. TERMINATION

The Airport Sponsor agrees that notwithstanding any other provisions of this TOA, the FAA's ability to provide contract ATC service is contingent upon the appropriation of adequate funds. If adequate annual appropriations are not provided, the FAA may terminate this Agreement without penalty.

In addition to any other termination rights provided by this Agreement, either party may terminate this Agreement at any time prior to its expiration date, with or without cause, and without incurring any liability or obligation to the terminated party (other than payment of amounts due and owing and performance of obligations accrued, in each case on or prior to the termination date) by giving the other party at least Ninety (90) days prior written notice of termination. Upon receipt of a notice of termination, the receiving party shall take immediate steps to stop the accrual of any additional obligations, which might require payment.

IX. TERM OF THE AGREEMENT

This Agreement shall automatically renew annually on the effective date unless terminated by either of the parties in writing, as provided herein.

X. DISPUTES

Where possible, disputes will be resolved by informal discussion between the parties. In the event the parties are unable to resolve any disagreement through good faith negotiations, the Director of Operations- Headquarters (AJT-2) will resolve the dispute. The decision of the Director of Operations-Headquarters is not subject to further administrative review and, to the extent permitted by law, is final and binding.

XI. INSURANCE

The Airport Sponsor shall arrange by insurance or otherwise for the full protection of the Airport Sponsor from and against all liability to third parties arising out of, or related to, the performance of this Agreement to the extent permitted by law. *(If necessary, Airport Sponsor may insert a description of any State laws that apply here.)*

XII. LIABILITY

The FAA assumes no liability under this Agreement for any losses arising out of any action or inaction by the Airport Sponsor, its employees or contractors, or any third party acting on its behalf. The Airport Sponsor agrees to hold the FAA harmless against any claim by third persons for injury, death, or property damage arising out of or in connection with the Airport Sponsor's performance under this Agreement.

XIII. LEGAL AUTHORITY

This "other transaction" MOU is entered into under the authority of 49 U.S.C. §§ 106 (f)(2)(A) and 106(l) and (m), which authorizes agreements and other transactions on such terms and conditions as the Administrator determines necessary. This MOU is not a Memorandum of Agreement, procurement contract, grant or cooperative agreement. Nothing in this Agreement shall be construed as incorporating by reference or implication any provision of Federal acquisition law or regulation.

XIV. CIVIL RIGHTS ACT

The Airport Sponsor shall comply with Title VI of the Civil Rights Act of 1964 relating to nondiscrimination in federally assisted programs and, if requested, provide a certification to that effect.

XV. PROTECTION OF INFORMATION

The parties agree that they shall take appropriate measures to protect proprietary, privileged, or otherwise confidential information that may come into their possession as a result of this MOU.

XVI. FUNDING

No funds are obligated under this MOU. Each party shall bear the full cost it incurs in performing, managing, and administering its responsibilities under this MOU.

XVII. CONSTRUCTION

Parties agree to exercise good faith in achieving the goals of this MOU; this means that the Government will adopt and perform the above delineated roles and responsibilities and will provide air traffic control services for the above designated airport sponsor at the designated location. The Airport Sponsor also agrees to adopt and perform the above delineated roles and responsibilities. Neither party is authorized or empowered to act on behalf of the other with regard to any matter, and neither party shall be bound by the acts or conduct of the other in connection with any activity under this MOU. This provision shall survive termination of this MOU. The undersigned TOA holder affirms that this MOU is entered knowingly and voluntarily.

The FAA reserves the right to withdraw FAA funding for ATC services from Airport Sponsors that do not comply with the terms of this agreement.

AGREED:

Airport Sponsor

Federal Aviation Administration

BY: _____

BY: _____

TITLE: _____

TITLE: _____

DATE: _____

DATE: _____

Consideration of Lea County Resolution No. 19-MAR-097R Approving the 2nd Option to Renew (Proposal No. 02 2015 – 2016) Agreement between Lea County and Securus Technologies, Inc. for Inmate Telephone Equipment and Service Agreement for the Lea County Detention Center.



- ▶ Proposal No. 02 2015 – 2016 was Awarded to Securus Technologies
- ▶ 1st Option to Renew was approved on October 19, 2017

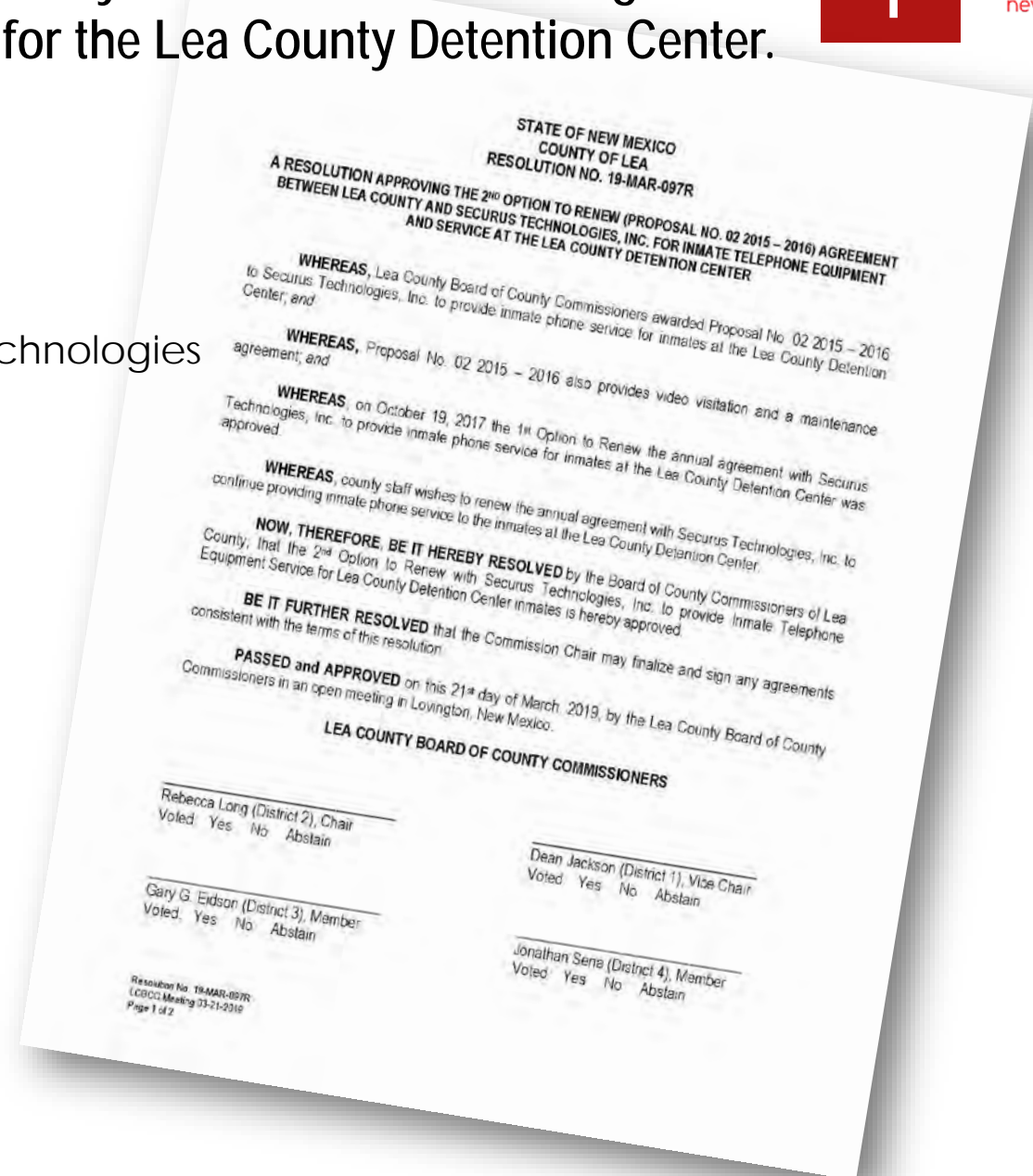



**LEA COUNTY BOARD OF COUNTY COMMISSIONERS
AGENDA ITEM SUMMARY FORM**

LCBCC Meeting Date: Thursday, March 21, 2019

Submit this summary form & all attachments to the Finance Director clow@leacounty.net & cc the Executive Coordinator ssout@leacounty.net by: **March 5, 2019**

County Manager Approval (mgallagher@leacounty.net) required for all time sensitive issues that do not meet the above deadline.

DATE SUBMITTED mm-dd-yyyy: 03/14/2019		SUBMITTED BY Name/Title/Dept: Warden Ruben Quintana	
SUBJECT: 2nd OTR Inmate Telephone Equipment & Service Agreement with Securus Technologies Inc.		ATTACHMENT(S): 2nd OTR Inmate Telephone Equipment & Service Agreement with Securus Technologies Inc.	
NO. OF ORIGINALS FOR SIGNATURE: 01 Resolution 02 Agreement 00 ***Select One**		ACTION REQUESTED: Action Item	
STRATEGIC PLAN Implementation of 5 Year Strategic Plan:			
SUMMARY: Proposal No 02 (15-16) provides inmate telephone service for Lea County Detention Center inmates. This proposal also provides video visitation and a maintenance agreement for Lea County Detention Center inmates. There is no financial impact to Lea County with this agreement.			
Requested Items Needed for Presentation Easels/Laptop/Projector/Etc.:		See Additional Summary Attached <input type="checkbox"/>	
Easel <input type="checkbox"/> Laptop <input checked="" type="checkbox"/> Projector <input checked="" type="checkbox"/> Other: _____ <small>If checked, how many:</small>			
SUBMITTER'S RECOMMENDATION(S): Approve and sign agreement between Lea County and Securus Technologies, Inc.		Submitter's Signature Department Director, Etc. <i>Ruben Quintana</i>	
FINANCE REVIEW Fiscal Impact/Cost: There is no financial impact to Lea County with this agenda item.		Reviewed by Finance Director Henry C Low Jr Digitally signed by Henry C Low Jr Date: 2019.03.18 08:27:45 -06'00'	
LEGAL REVIEW: (Note: Travel does not need legal review)		Reviewed by County Attorney	
COUNTY MANAGER REVIEW:		Approved by County Manager to be Placed on Agenda Digitally signed by Michael P. Gallagher <i>Michael P. Gallagher</i> Date: 2019.03.20 16:29:55 -06'00'	
Item 0204 RECORDING SECRETARY'S USE ONLY ~ COMMISSION ACTION TAKEN			
Approved: _____		Denied: _____	
Resolution No. <u>19-MAR-097R</u>		Policy No. _____	
Continued To: _____		Referred To: _____	
		Other: _____	
		Ordinance No. _____	
		Comments: _____	

STATE OF NEW MEXICO
COUNTY OF LEA
RESOLUTION NO. 19-MAR-097R

**A RESOLUTION APPROVING THE 2ND OPTION TO RENEW (PROPOSAL NO. 02 2015 – 2016) AGREEMENT
BETWEEN LEA COUNTY AND SECURUS TECHNOLOGIES, INC. FOR INMATE TELEPHONE EQUIPMENT
AND SERVICE AT THE LEA COUNTY DETENTION CENTER**

WHEREAS, Lea County Board of County Commissioners awarded Proposal No. 02 2015 – 2016 to Securus Technologies, Inc. to provide inmate phone service for inmates at the Lea County Detention Center; *and*

WHEREAS, Proposal No. 02 2015 – 2016 also provides video visitation and a maintenance agreement; *and*

WHEREAS, on October 19, 2017 the 1st Option to Renew the annual agreement with Securus Technologies, Inc. to provide inmate phone service for inmates at the Lea County Detention Center was approved.

WHEREAS, county staff wishes to renew the annual agreement with Securus Technologies, Inc. to continue providing inmate phone service to the inmates at the Lea County Detention Center.

NOW, THEREFORE, BE IT HEREBY RESOLVED by the Board of County Commissioners of Lea County, that the 2nd Option to Renew with Securus Technologies, Inc. to provide Inmate Telephone Equipment Service for Lea County Detention Center inmates is hereby approved.

BE IT FURTHER RESOLVED that the Commission Chair may finalize and sign any agreements consistent with the terms of this resolution.

PASSED and APPROVED on this 21st day of March, 2019, by the Lea County Board of County Commissioners in an open meeting in Lovington, New Mexico.

LEA COUNTY BOARD OF COUNTY COMMISSIONERS

Rebecca Long (District 2), Chair
Voted: Yes No Abstain

Dean Jackson (District 1), Vice Chair
Voted: Yes No Abstain

Gary G. Eidson (District 3), Member
Voted: Yes No Abstain

Jonathan Sena (District 4), Member
Voted: Yes No Abstain

Richard Don Jones (District 5), Member
Voted: Yes No Abstain

ATTEST: Keith Manes
Lea County Clerk

**APPROVED AS TO FORM AND LEGAL
SUFFICIENCY:**

By: _____
Kelli Williams, Deputy Clerk

John W. Caldwell, County Attorney

2018-2019 -- (2nd) OPTION TO RENEW

INMATE TELEPHONE EQUIPMENT AND SERVICE

THIS AGREEMENT is made between the LEA COUNTY BOARD OF COMMISSIONERS, acting by and through its Chairman and located in the County of Lea, State of New Mexico, (hereinafter referred to as "COUNTY") and **SECURUS TECHNOLOGIES, INC.** located at 4000 International Parkway, Carrollton, TX 75007, (hereinafter referred to as "Securus").

WHEREAS, the COUNTY has engaged Securus for inmate telephone equipment services for the COUNTY;

NOW THEREFORE, the COUNTY hereby exercises their right to renew **Request for Proposal (RFP) #02 - (15-16)** for a 12-month term **beginning October 27, 2018 ending October 27, 2019**, upon the *same specifications, terms and conditions contained in the original RFP.*

IN WITNESS WHEREOF, we have hereunto affixed our hands and seals this

21st day of March, 2019.

SECURUS TECHNOLOGIES, INC

BOARD OF COUNTY COMMISSIONERS
LEA COUNTY, NEW MEXICO

[Signature]

By: _____
Rebecca Long, Chair



Keith Manes
Lea County Clerk

Approved as to form & legal sufficiency:

By: _____
Kelli Williams, Deputy Clerk

John W. Caldwell, County Attorney

STATE OF Texas)
COUNTY OF Denton) ss.

The foregoing instrument was acknowledged before me this 3rd day of
January, 2018 by Robert Pickens, President/CEO
(Name) (Title)
of Securus Technologies, Inc. a Delaware corporation, on
(Corporation) (Place of Incorporation)
behalf of said corporation.

My Commission Expires: September 7, 2021 Cindy A. Carey
Notary Public

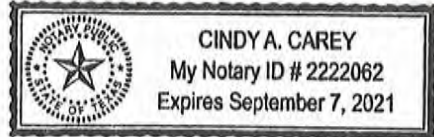

Consideration of Lea County Resolution No. 19-MAR-098R Approving Public Employees Retirement Association (PERA) Volunteer Fire Departments Annual Reporting for Knowles, Maljamar and Monument.

Emergency Management & Fire Marshal

Request Approval to submit Annual Volunteer Firefighters Reporting form to PERA for Service credit of Volunteer Firefighters

- ▶ Knowles Fire 21 Volunteers
- ▶ Maljamar Fire 10 Volunteers
- ▶ Monument Fire 10 Volunteers





**LEA COUNTY BOARD OF COUNTY COMMISSIONERS
AGENDA ITEM SUMMARY FORM**

LCBCC Meeting Date: Thursday, March 21, 2019

Submit this summary form & all attachments to the Finance Director clow@leacounty.net & cc the Executive Coordinator sstout@leacounty.net by: **March 5, 2019**

County Manager Approval (mgallagher@leacounty.net) required for all time sensitive issues that do not meet the above deadline.

DATE SUBMITTED mm-dd-yyyy: 03/13/2019		SUBMITTED BY Name/Title/Dept: Lorenzo Velasquez Director, Emergency Management	
SUBJECT: Volunteer Firefighters Annual Reporting Form		ATTACHMENT(S): three	
NO. OF ORIGINALS FOR SIGNATURE: 01 Resolution 00 ***Select One** 00 ***Select One**		ACTION REQUESTED: Action Item	
STRATEGIC PLAN Implementation of 5 Year Strategic Plan: Section 3.4 Lower ISO ratings for county fire districts			
SUMMARY: Request approval to submit annual Volunteer firefighters Reporting Form for Knowles, Maljamar and Monument Volunteer Fire Departments to PERA			
Requested Items Needed for Presentation Easels/Laptop/Projector/Etc.: Easel <input type="checkbox"/> Laptop <input checked="" type="checkbox"/> Projector <input checked="" type="checkbox"/> Other: _____ <small>If checked; how many.</small>			See Additional Summary Attached <input type="checkbox"/>
SUBMITTER'S RECOMMENDATION(S): Request Approval			Submitter's Signature Department Director, Etc.
FINANCE REVIEW Fiscal Impact/Cost: There is no financial impact to Lea County with this agenda item.			Reviewed by Finance Director Henry C Low Jr Digitally signed by Henry C Low Jr Date: 2019.03.15 13:42:42 -06'00'
LEGAL REVIEW: (Note: Travel does not need legal review)			Reviewed by County Attorney
COUNTY MANAGER REVIEW:			Approved by County Manager to be Placed on Agenda Digitally signed by Michael P. Gallagher <i>Michael P. Gallagher</i> Date: 2019.03.20 14:55:53 -06'00'
Item 0205 RECORDING SECRETARY'S USE ONLY ~ COMMISSION ACTION TAKEN			
Approved: _____		Denied: _____	
Resolution No. <u>19-MAR-098R</u>		Policy No. _____	
Continued To: _____		Referred To: _____	
		Other: _____	
		Ordinance No. _____	
		Comments: _____	

STATE OF NEW MEXICO
COUNTY OF LEA
RESOLUTION NO. 19-MAR-098R

A RESOLUTION APPROVING PUBLIC EMPLOYEES RETIREMENT ASSOCIATION (PERA)
VOLUNTEER FIRE DEPARTMENTS ANNUAL REPORTING FOR
KNOWLES, MALJAMAR AND MONUMENT

WHEREAS, Lea County shall notarize and submit an Annual Volunteer Firefighters Reporting Form to Public Employees Retirement Association of New Mexico; *and*

WHEREAS, Lea County has prepared the 2018 Annual Reporting (PERA) Form from the Volunteer Fire Departments (Knowles, Maljamar, Monument) to report the personnel roster of each Volunteer Fire Department for service credit; *and*

NOW THEREFORE BE IT HEREBY RESOLVED by the Board of County Commissioners of Lea County, that Lea County shall submit its Annual Reporting Form to PERA.

BE IT FURTHER RESOLVED that the County Manager may finalize this request with the terms of this resolution and in the best interests of Lea County, and that the Chair of the Board of County Commissioners may sign the request on behalf of the Board of County Commissioners of Lea County.

PASSED and APPROVED on this 21st day of March, 2019, by the Lea County Board of County Commissioners in an open meeting in Lovington, New Mexico.

LEA COUNTY BOARD OF COUNTY COMMISSIONERS

Rebecca Long (District 2), Chair
Voted: Yes No Abstain

Dean Jackson (District 1), Vice Chair
Voted: Yes No Abstain

Gary G. Eidson (District 3), Member
Voted: Yes No Abstain

Jonathan Sena (District 4), Member
Voted: Yes No Abstain

Richard Don Jones (District 5), Member
Voted: Yes No Abstain

ATTEST: Keith Manes
Lea County Clerk

**APPROVED AS TO FORM AND LEGAL
SUFFICIENCY:**

By: _____
Kelli Williams, Deputy Clerk

John W. Caldwell, County Attorney



33 Plaza La Prensa, Santa Fe, New Mexico 87507
 (505) 476-9300 voice
 (800) 342-3422 toll-free
www.nmpera.org

2018 Volunteer Firefighters Annual Reporting Form

SECTION A – VOLUNTEER FIREFIGHTER DEPARTMENT – GENERAL INFORMATION

1. Department Name: Knowles Fire Department

2. Department Mailing Address: 515 E Pinson Road
 City, State: Hobbs, NM Zip Code: 88242

3. PERA VFD Number (5 digit number): 09694

4. Fire Chief: Michael Singleton Email Address: msingleton@leacounty.net

5. Phone (work): (575) 399-3904 (home): (575) 631-1724

SECTION B – DEPARTMENT TOTALS

1.	New Member Enrollments reported this year:	4
2.	Current Active (Non-Retired) Members reported this year:	17
3.	Retired Members with Continuing Service reported this year:	2
4.	Total number of Volunteer Firefighters reported this year:	21

SECTION C - CERTIFICATION

I, Michael Singleton, Fire Chief of Knowles
 Volunteer Firefighter Department, affirm that the records submitted to PERA are true and correct and reflect 100% of my Department's 2018 roster.

Signature of Fire Chief: [Signature] Date: 3-12-19

Municipal Mayor or Chair of County Commission: Rebecca Long Date: 3-21-2019

State of New Mexico)
 County of Lea) SS:

Subscribed and sworn to before me by Michael Singleton on this the 12 day of March, 2019
(Printed name of Fire Chief)

My Commission Expires 06/24/2019 Notary Public Telephone No: 575-396-8600

Notary Signature: [Signature]



Return this form on or before March 31 of each calendar year to the Public Employees Retirement Association. Keep a copy for your department's records. Strikethroughs and white-out edits are not permitted.



33 Plaza La Prensa, Santa Fe, New Mexico 87507
 (505) 476-9300 voice
 (800) 342-3422 toll-free
www.nmpera.org

2018 Volunteer Firefighters Annual Reporting Form

SECTION A – VOLUNTEER FIREFIGHTER DEPARTMENT – GENERAL INFORMATION

1. Department Name: Maljamar Volunteer Fire Department

2. Department Mailing Address: P.O. Box 157
 City, State: Maljamar New Mexico Zip Code: 88264

3. PERA VFD Number (5 digit number): 09720

4. Fire Chief: Curry W. Pruitt Email Address: cpruit@leacounty.net

5. Phone (work): (575) 441-0214 (home): ()

SECTION B – DEPARTMENT TOTALS

1.	New Member Enrollments reported this year:	1
2.	Current Active (Non-Retired) Members reported this year:	9
3.	Retired Members with Continuing Service reported this year:	0
4.	Total number of Volunteer Firefighters reported this year:	10

SECTION C - CERTIFICATION

I, Curry W. Pruitt, Fire Chief of Maljamar Volunteer Fire Department
 Volunteer Firefighter Department, affirm that the records submitted to PERA are true and correct and reflect 100% of my Department's 2018 roster.

Signature of Fire Chief: *Curry W. Pruitt* Date: 2-20-2019

Municipal Mayor or Chair of County Commission: Rebecca Long Date: 3-21-2019

State of New Mexico)
 County of Lea) SS:

Subscribed and sworn to before me by Curry W. Pruitt on this the 20 day of Feb, 2019
(Printed name of Fire Chief)

My Commission Expires 06/24/2019 Notary Public Telephone No: 575-394-8600

Notary Signature: *[Signature]*



Return this form on or before March 31 of each calendar year to the Public Employees Retirement Association. Keep a copy for your department's records. Strikethroughs and white-out edits are not permitted.

2018 Volunteer Firefighters Annual Reporting Form

SECTION A – VOLUNTEER FIREFIGHTER DEPARTMENT – GENERAL INFORMATION

1. Department Name: Monument Fire Dept.
2. Department Mailing Address: Po Box 16
City, State: Monument nm Zip Code: 88260
3. PERA VFD Number (5 digit number): 09732
4. Fire Chief: Justin Solomon Email Address: ChiefSolomon@hotmail.com
5. Phone (work): (575) 390-4054 (home): ()

SECTION B – DEPARTMENT TOTALS

1.	New Member Enrollments reported this year:	1
2.	Current Active (Non-Retired) Members reported this year:	9
3.	Retired Members with Continuing Service reported this year:	0
4.	Total number of Volunteer Firefighters reported this year:	10

SECTION C - CERTIFICATION

I, Justin Solomon, Fire Chief of Monument Fire Dept
Volunteer Firefighter Department, affirm that the records submitted to PERA are true and correct and reflect 100% of my Department's 2018 roster.

Signature of Fire Chief Justin N. Solomon

Date 3-11-19

Lea County

Municipal Mayor or Chair of County Commission
Rebecca Long

Date 3-21-2019

MAR 21 2019
CBCC Meeting

State of New Mexico)
County of Lea) SS:

Subscribed and sworn to before me by Justin Solomon on this the 11 day of March, 2019
(Printed name of Fire Chief)

My Commission Expires 06/24/2019 Notary Public Telephone No: 575-396-8600

Notary Signature [Signature]

Return this form on or before March 31 of each calendar year to the Public Employees Retirement Association. Keep a copy for your department's records. Strikethroughs and white-out edits are not permitted.

Consideration of Lea County Resolution No. 19-MAR-099R Approving a Change Order between Lea County and Lasco Construction for the North Parking Lot Gates.



March 1, 2019

Lea County
100 W. Main Suite 11
Lovington, NM 88260
Attn: Erich Franke
Re: Lea County Parking Lot Improvements
Change Order 2 - REVISION 2

Below is the cost for the requested changes:

Gate

1. 26' x 6' single slide custom built XL enclosed track cantilever gate over all length 40', 3" X 3" trussed frame, standard ornamental picket design.
2. Includes all required foundations, post and hardware
3. Max 3200 commercial slide gate operator
4. Gate operators stand
5. Loop sensors
6. Safety entrapment contact sensors and photo eye
7. Drive up goose-neck pedestal with two (2) each bollards
8. Parking lot gates 20' x 8' pair of double drive swing gate to match 3" x 3" trussed frame, standard ornamental picket design
9. Set with 6" x 6" - 4" post

10. Custom built pedestrian gate to be installed in wall opening. Design to match, includes panic bar and hydraulic self closing hinges
11. Dumpster gates 20' x 8' pair of double drive swing gates to match 3" x 3" trussed frame, standard ornamental picket design. Set with 6" x 6" - 4" post
12. All to be epoxy painted bone white or color of choice
13. Total installed job cost below
14. Scale wages included

Price	962,753.00
18% P/O	16,699.54
Less 4% Discount	<u>18,377.94</u>
	105,070.60
Bond	2,101.41
Tax 7.2500%	107,172.01
Total	<u>\$114,941.98</u>

Exclusions: electrical, low voltage, and access controls, private staking, core drilling, concrete removal, final flat work.

If you have any questions please let me know.

Sincerely,

John Bergsdal
President





**LEA COUNTY BOARD OF COUNTY COMMISSIONERS
AGENDA ITEM SUMMARY FORM**

LCBCC Meeting Date: Thursday, March 21, 2019

Submit this summary form & all attachments to the Finance Director clow@leacounty.net & cc the Executive Coordinator sstout@leacounty.net by: **March 5, 2019**

County Manager Approval (mgallagher@leacounty.net) required for all time sensitive issues that do not meet the above deadline.

DATE SUBMITTED mm-dd-yyyy: 03/14/2019		SUBMITTED BY Name/Title/Dept: Erich Francke - Facilities Director	
SUBJECT: Gate change order for North Parking Lot to Lasco Construction.		ATTACHMENT(S): Change order 2 from Lasco Construction dated March 1, 2019.	
NO. OF ORIGINALS FOR SIGNATURE: 01 Resolution 00 ***Select One** 00 ***Select One**		ACTION REQUESTED: Action Item	
STRATEGIC PLAN Implementation of 5 Year Strategic Plan:			
SUMMARY: The gate change order will supply a secure drive through gate, pedestrian secure walk through gate, a double trash bin gate and a double manual drive through gate for \$137,929. This price includes gates and contingency.			
Requested Items Needed for Presentation Easels/Laptop/Projector/Etc.: Easel <input type="checkbox"/> Laptop <input checked="" type="checkbox"/> Projector <input checked="" type="checkbox"/> Other: _____ <small>If checked, how many.</small>		See Additional Summary Attached <input type="checkbox"/>	
SUBMITTER'S RECOMMENDATION(S): Approve gate change order for North Parking Lot for \$114,941.98 plus 20% contingency for a total of \$137,929.20.		Submitter's Signature Department Director, Etc. Erich L. Francke <small>Digitally signed by Erich L. Francke DN: cn = Erich L. Francke email = efrancke@leacounty.net C = US O = Lea County OU = Facilities Date: 2019.03.14 16:12:55 -0700'</small>	
FINANCE REVIEW Fiscal Impact/Cost: The financial impact to Lea County will be expenditures of up to \$137,929.20. Funds are budgeted and available in 430-004333.		Reviewed by Finance Director Henry C Low Jr <small>Digitally signed by Henry C Low Jr Date: 2019.03.15 13:31:03 -06'00'</small>	
LEGAL REVIEW: (Note: Travel does not need legal review)		Reviewed by County Attorney	
COUNTY MANAGER REVIEW:		Approved by County Manager to be Placed on Agenda <small>Digitally signed by Michael P. Gallagher Date: 2019.03.20 15:59:02 -06'00'</small>	
Item 0206 RECORDING SECRETARY'S USE ONLY ~ COMMISSION ACTION TAKEN			
Approved: _____ Resolution No. <u>19-MAR-099R</u> Continued To: _____		Denied: _____ Policy No. _____ Referred To: _____	
		Other: _____ Ordinance No. _____ Comments: _____	

STATE OF NEW MEXICO
COUNTY OF LEA
RESOLUTION NO. 19-MAR-099R

A RESOLUTION APPROVING A CHANGE ORDER BETWEEN LEA COUNTY AND LASCO
CONSTRUCTION FOR THE NORTH PARKING LOT GATES

WHEREAS, Lea County is under Cooperative Educations Services (CES) contract with Lasco Construction to reconstruct the north parking lot; *and*

WHEREAS, the gate change order will supply a secure drive through gate, pedestrian secure walk through gate, a double trash bin gate and a double manual drive through gate; *and*

WHEREAS, Lasco Construction has issued a gate change order for the north parking lot for \$114,941.98 plus contingency for a total of \$137,929.20.

NOW, THEREFORE, BE IT HEREBY RESOLVED by the Board of County Commissioners of Lea County, that the change order for the north parking lot gates to Lasco Construction for \$137,929.20 is hereby approved.

BE IT FURTHER RESOLVED that the Commission Chair may finalize and sign any agreements consistent with the terms of this resolution.

PASSED and APPROVED on this 21st day of March, 2019, by the Lea County Board of County Commissioners in an open meeting in Lovington, New Mexico.

LEA COUNTY BOARD OF COUNTY COMMISSIONERS

Rebecca Long (District 2), Chair
Voted: Yes No Abstain

Dean Jackson (District 1), Vice Chair
Voted: Yes No Abstain

Gary G. Eidson (District 3), Member
Voted: Yes No Abstain

Jonathan Sena (District 4), Member
Voted: Yes No Abstain

Richard Don Jones (District 5), Member
Voted: Yes No Abstain

ATTEST: Keith Manes
Lea County Clerk

**APPROVED AS TO FORM AND LEGAL
SUFFICIENCY:**

By: _____
Kelli Williams, Deputy Clerk

John W. Caldwell, County Attorney



License No. 13641

PHONE (575) 393-9161
FAX (575) 397-4993

BOX 877

314 W. MARLAND

HOBBS, N.M. 88241

March 1, 2019

Lea County
100 N. Main Suite 11
Lovington, NM 88260

Attn: Erich Franke

Re: Lea County Parking Lot Improvements
Change Order 2 - REVISION 2

Below is the cost for the requested changes:

Gate

1. 26" x 8' single slide custom built XL enclosed track cantilever gate over all length 40'. 3" X 3" Trussed frame, standard ornamental picket design.
2. Includes all required foundations, post and hardware
3. Max 2200 commercial slide gate operator
4. Gate operators stand
5. Loop sensors
6. Safety entrapment contact sensors and photo eye
7. Drive up gooseneck pedestal with two (2) each bollards
8. Parking lot gates 20' x 8' pair of double drive swing gate to match. 3" x 3" trussed frame, standard ornamental picket design
9. Set with 6" x 6" - 1/4" post

10. Custom built pedestrian gate to be installed in wall opening. Design to match, includes panic bar and hydraulic self closing hinges
11. Dumpster gates 20' x 8' pair of double drive swing gates to match. 3" x 3" trussed frame, standard ornamental picket design. Set with 6" x 6" - 1/4" post
12. All to be epoxy painted bone white or color of choice
13. Total installed job cost below
14. Scale wages included

Price	\$92,753.00
18% P/O	16,695.54
	<u>109,448.54</u>
Less 4% Discount	(4,377.94)
	105,070.60
Bond	2,101.41
	<u>107,172.01</u>
Tax 7.2500%	7,769.97
Total	<u>\$114,941.98</u>

Exclusions: electrical, low voltage, and access controls, private staking, core drilling, concrete removal, final flat work.

If you have any questions please let me know.

Sincerely,



John Ragsdal
President

Consideration of Lea County Resolution No. 19-MAR-100R Approving a Water Supply Equipment Replacement for the Lea County Detention Center.

Donner Plumbing & Heating Inc.

107 Candelaria NW, Albuquerque NM, 87107 - P/ 505-884-1017 - F/ 505-884-1165
 NM MM-98 # 10017 Texas - RMP#42138
 NM DOL # 0001920060701

BID PROPOSAL

Date: 3/13/2019
 Project: LCDC – Booster Pump and Backflow Replacement

We are pleased to provide the following bid for the above named project:

- Provide and install temporary 4" domestic water bypass with dual inline check in pump room
- Demo and disposal of existing booster pump and backflow
- Provide and install new meter vault, backflows, hot boxes and all necessary piping as shown
- Provide and install new booster pump, all necessary piping and wiring as shown
- Provide and install hydro pneumatic tanks and all associated piping as shown
- Provide and install 4" domestic water sub-meter (*no controls integration*)
- Provide and install 4" emergency solenoid valve and associated wiring
- Insulation patch and repair on new work
- Electrical as shown
- Provide concrete cutting, coring, patching and new housekeeping pads
- Landscape repair as needed (*see exclusion #f*)

Bond is included our bid

The following addenda are acknowledged. 0

We offer the following prices (*excluding New Mexico gross receipts tax*) firm for 60 days from bid date. 2.5% fee will be charged for credit card payments of \$2,500.00 and up - Payment Terms Net 30

Base Bid ----- \$ 319,533.00

CES Contract# - 2016-002D RFP-C

Not included in our bid

- 1) Controls integration
- 2) Holidays or weekends
- 3) No provision has been included in our exca hazardous conditions. Should such obstacle alternatives and costs will be required.
- 4) Relocation or replacement of trees affected

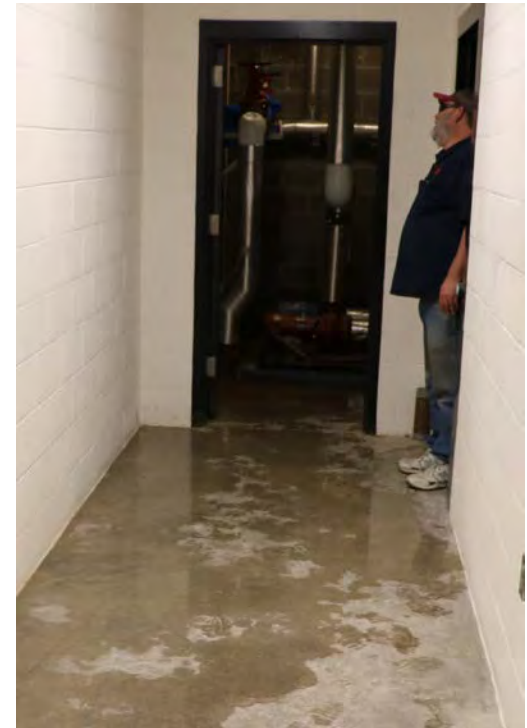

Donner Plumbing & Heating Inc.
 107 Candelaria NW, Albuquerque NM, 87107 - P/ 505-884-1017 - F/ 505-884-1165
 NM MM-98 # 10017 Texas - RMP#42138
 NM DOL # 0001920060701
 Date: 3/13/2019
 Project: LCDC – Booster Pump and Backflow Replacement

- 5) Requirements for additional insured or waiver of subrogation
- 6) Temporary sewer, toilet facilities, heat, or water
- 7) Pro-rata utility costs, restoration fees, utility expansion charges, and standby charges
- 8) Meter cost and fees
- 9) Asbestos or Hazardous materials abatement
- 10) Fire protection or fire alarm

Name of Bonding Company: United Fire & Casualty
 Name of Local Agent: Burke Insurance Phone: 505-574-2122
 Please do not hesitate to call me at 505-884-1017 if you have any questions.



LEA COUNTY BOARD OF COUNTY COMMISSIONERS
AGENDA ITEM SUMMARY FORM

LCBCC Meeting Date: Thursday, March 21, 2019

Submit this summary form & all attachments to the Finance Director clow@leacounty.net & cc the Executive Coordinator sstout@leacounty.net by: March 5, 2019

County Manager Approval (mgallagher@leacounty.net) required for all time sensitive issues that do not meet the above deadline.

Form with multiple sections: DATE SUBMITTED (03/14/2019), SUBJECT (Lea County Detention Center Domestic Water Supply Equipment Replacement), ATTACHMENT(S) (Plans Developed by Bridgers and Paxton. CES quote from Donner Plumbing.), ACTION REQUESTED (Action Item), SUMMARY (This project will move critical water equipment out of the building...), SUBMITTER'S RECOMMENDATION(S) (Approve CES quote to Donner Plumbing for \$319,533 plus 20% contingency of \$63,906.60 totaling \$383,439.60), FINANCE REVIEW (The financial impact to Lea County will be expenditures from the Detention Center Fund of up to \$383,439.60...), LEGAL REVIEW (Note: Travel does not need legal review), COUNTY MANAGER REVIEW (Approved by County Manager to be Placed on Agenda), and RECORDING SECRETARY'S USE ONLY ~ COMMISSION ACTION TAKEN (Approved: 19-MAR-100R, Denied: , Other: , Policy No., Ordinance No., Referred To: , Comments:)

STATE OF NEW MEXICO
COUNTY OF LEA
RESOLUTION NO. 19-MAR-100R

A RESOLUTION APPROVING A WATER SUPPLY EQUIPMENT REPLACEMENT FOR THE
LEA COUNTY DETENTION CENTER

WHEREAS, Lea County owns and operates the Lea County Detention Center located off Commercial Street, Lovington, NM; *and*

WHEREAS, this project will move critical water equipment out of the building and into a temperature controlled hot box for service purposes; *and*

WHEREAS, additional water pressure control booster pumps will be installed to help regulate city water pressure surges that will assist existing equipment to operate; *and*

WHEREAS, a Cooperative Education Services (CES) quote has been received from Donner Plumbing in the amount of \$319,533.00 plus contingency for a total of \$383,439.60.

NOW, THEREFORE, BE IT HEREBY RESOLVED by the Board of County Commissioners of Lea County, that the CES quote from Donner Plumbing to replace the domestic water supply equipment at the Lea County Detention Center is hereby approved.

BE IT FURTHER RESOLVED that the Commission Chair may finalize and sign any agreements consistent with the terms of this resolution.

PASSED and APPROVED on this 21st day of March, 2019, by the Lea County Board of County Commissioners in an open meeting in Lovington, New Mexico.

LEA COUNTY BOARD OF COUNTY COMMISSIONERS

Rebecca Long (District 2), Chair
Voted: Yes No Abstain

Dean Jackson (District 1), Vice Chair
Voted: Yes No Abstain

Gary G. Eidson (District 3), Member
Voted: Yes No Abstain

Jonathan Sena (District 4), Member
Voted: Yes No Abstain

Richard Don Jones (District 5), Member
Voted: Yes No Abstain

ATTEST: Keith Manes
Lea County Clerk

**APPROVED AS TO FORM AND LEGAL
SUFFICIENCY:**

By: _____
Kelli Williams, Deputy Clerk

John W. Caldwell, County Attorney

Donner Plumbing & Heating Inc.

107 Candelaria NW, Albuquerque NM, 87107 – P/ 505-884-1017 - F/ 505-884-1165

NM MM-98 # 10017
NM DOL # 0001920060701

Texas – RMP#42138

BID PROPOSAL

Date: 3/13/2019

Project: LCDC – Booster Pump and Backflow Replacement

We are pleased to provide the following bid for the above named project:

- Provide and install temporary 4” domestic water bypass with dual inline check in pump room
- Demo and disposal of existing booster pump and backflow
- Provide and install new meter vault, backflows, hot boxes and all necessary piping as shown
- Provide and install new booster pump, all necessary piping and wiring as shown
- Provide and install hydro pneumatic tanks and all associated piping as shown
- Provide and install 4” domestic water sub-meter (**no controls integration**)
- Provide and install 4” emergency solenoid valve and associated wiring
- Insulation patch and repair on new work
- Electrical as shown
- Provide concrete cutting, coring, patching and new housekeeping pads
- Landscape repair as needed (**see exclusion #4**)

Bond is included our bid

The following addenda are acknowledged. 0

We offer the following prices (**excluding New Mexico gross receipts tax**) firm for 60 days from bid date.
2.5% fee will be charged for credit card payments of \$2,500.00 and up - Payment Terms Net 30

Base Bid ----- \$ 319,533.00

CES Contract# - 2016-002D RFP-C

Not included in our bid

- 1) **Controls integration**
- 2) **Holidays or weekends**
- 3) **No provision has been included in our excavation for any rock or unforeseen underground obstacles or hazardous conditions. Should such obstacles or conditions be encountered, a separate evaluation of alternatives and costs will be required.**
- 4) **Relocation or replacement of trees affected by new meter vault and backflow preventers.**

Donner Plumbing & Heating Inc.

107 Candelaria NW, Albuquerque NM, 87107 – P/ 505-884-1017 - F/ 505-884-1165

NM MM-98 # 10017
NM DOL # 0001920060701

Texas – RMP#42138

Date: 3/13/2019

Project: LCDC – Booster Pump and Backflow Replacement

- 5) Requirements for additional insured or waiver of subrogation
- 6) Temporary sewer, toilet facilities, heat, or water
- 7) Pro-rata utility costs, restoration fees, utility expansion charges, and standby charges
- 8) Meter cost and fees
- 9) Asbestos or Hazardous materials abatement
- 10) Fire protection or fire alarm

Name of Bonding Company: United Fire & Casualty.
Name of Local Agent: Burke Insurance Phone: 505-575-2222

Please do not hesitate to call me at 505-884-1017 if you have any questions.

Date: Sep 25, 2018 - 11:19am User: ACBenovides Drawing File: H:\7472.03\CAD\AutoCAD\Lea County\Detention Domestic Booster\Sheets\PP101.dwg Last Saved By: ACBenovides Sep 24, 2018 - 3:56pm Layout Name: LEVEL 1 - PRESSURE PIPING PLAN

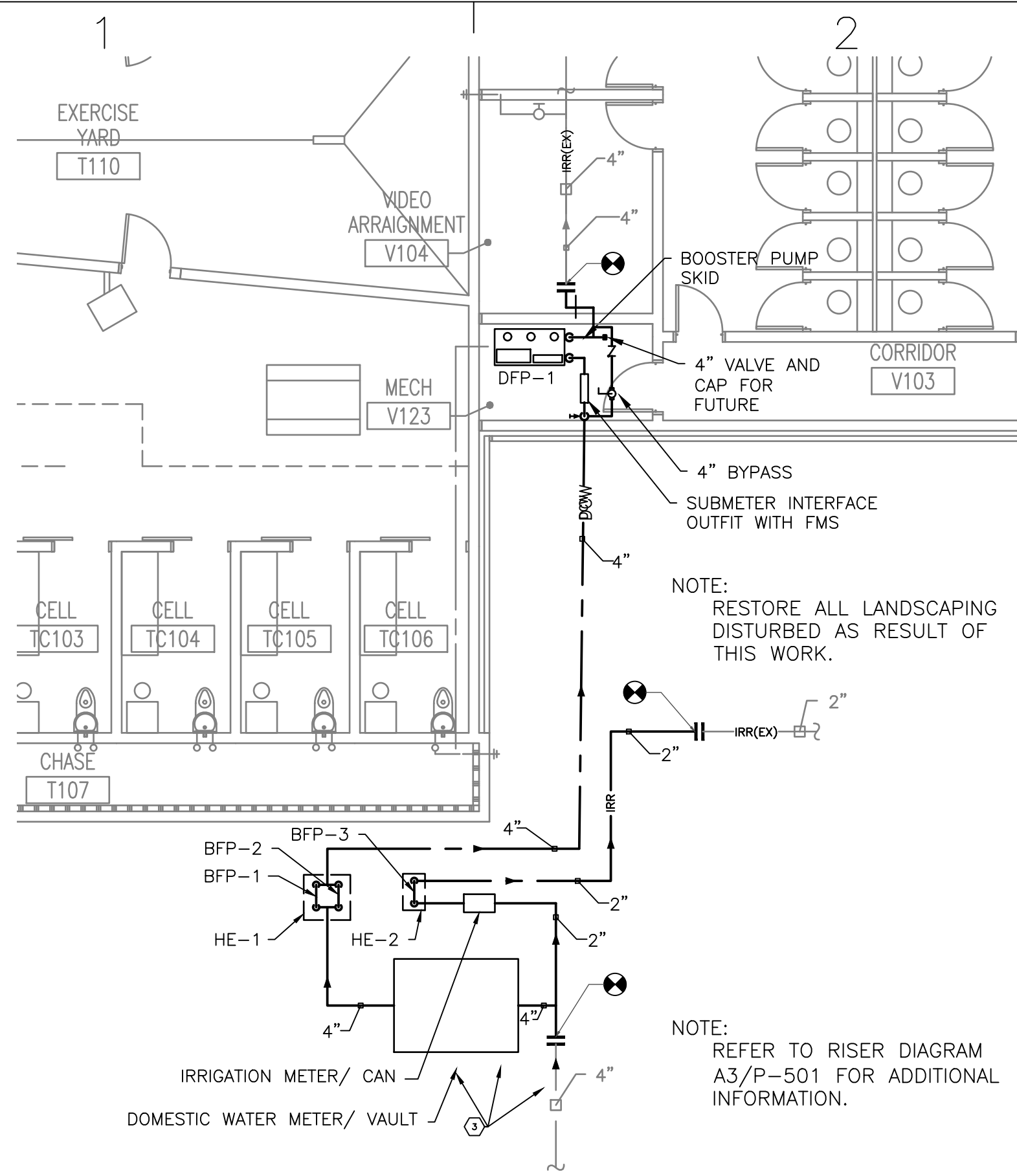

D1 NEW WORK ENLARGED PLAN
SCALE: 1/8" = 1'-0"
0 4' 8' 16'
SCALE: 1/8" = 1'-0"

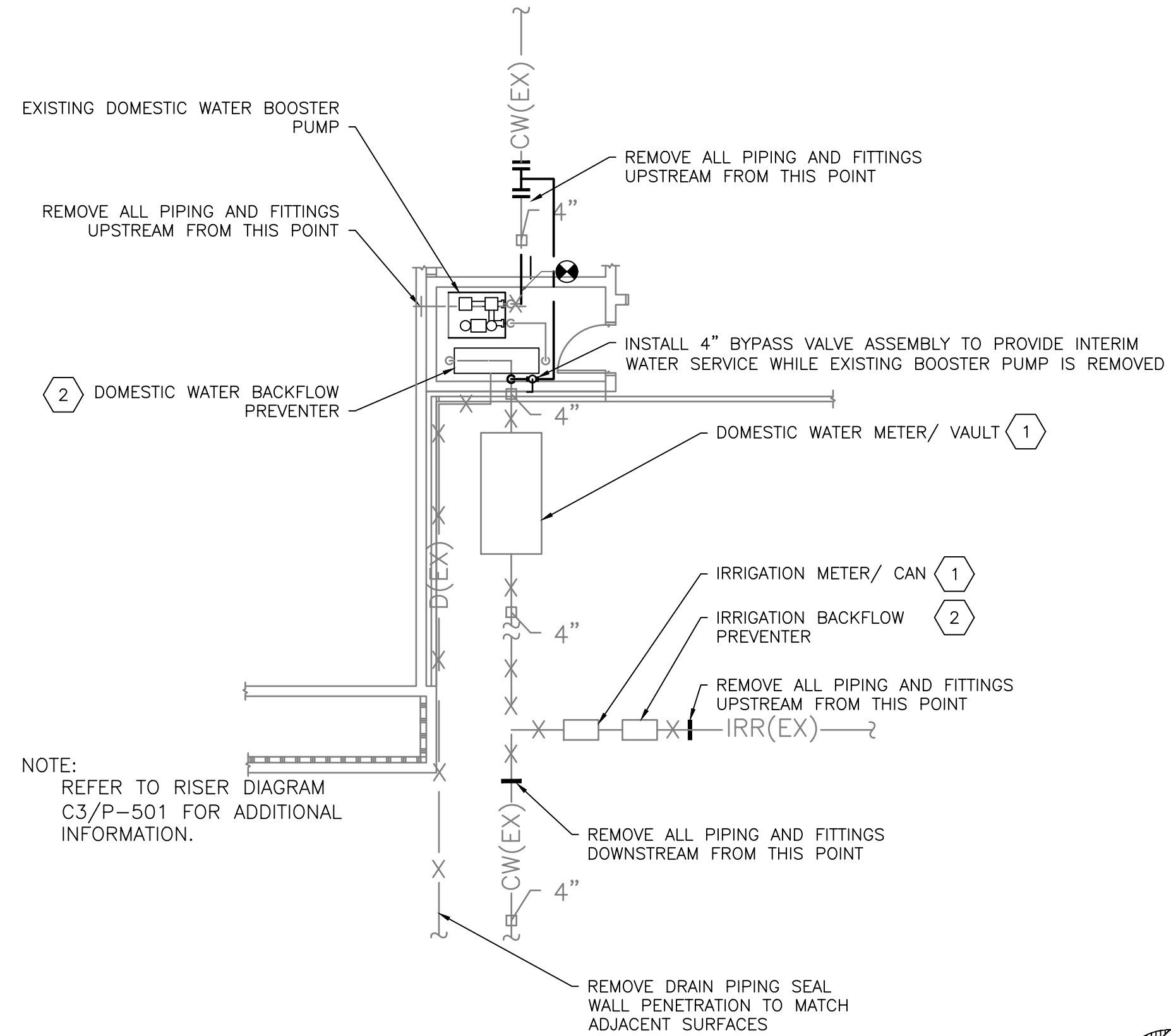

D3 DEMOLITION ENLARGED PLAN
SCALE: 1/8" = 1'-0"
0 4' 8' 16'
SCALE: 1/8" = 1'-0"

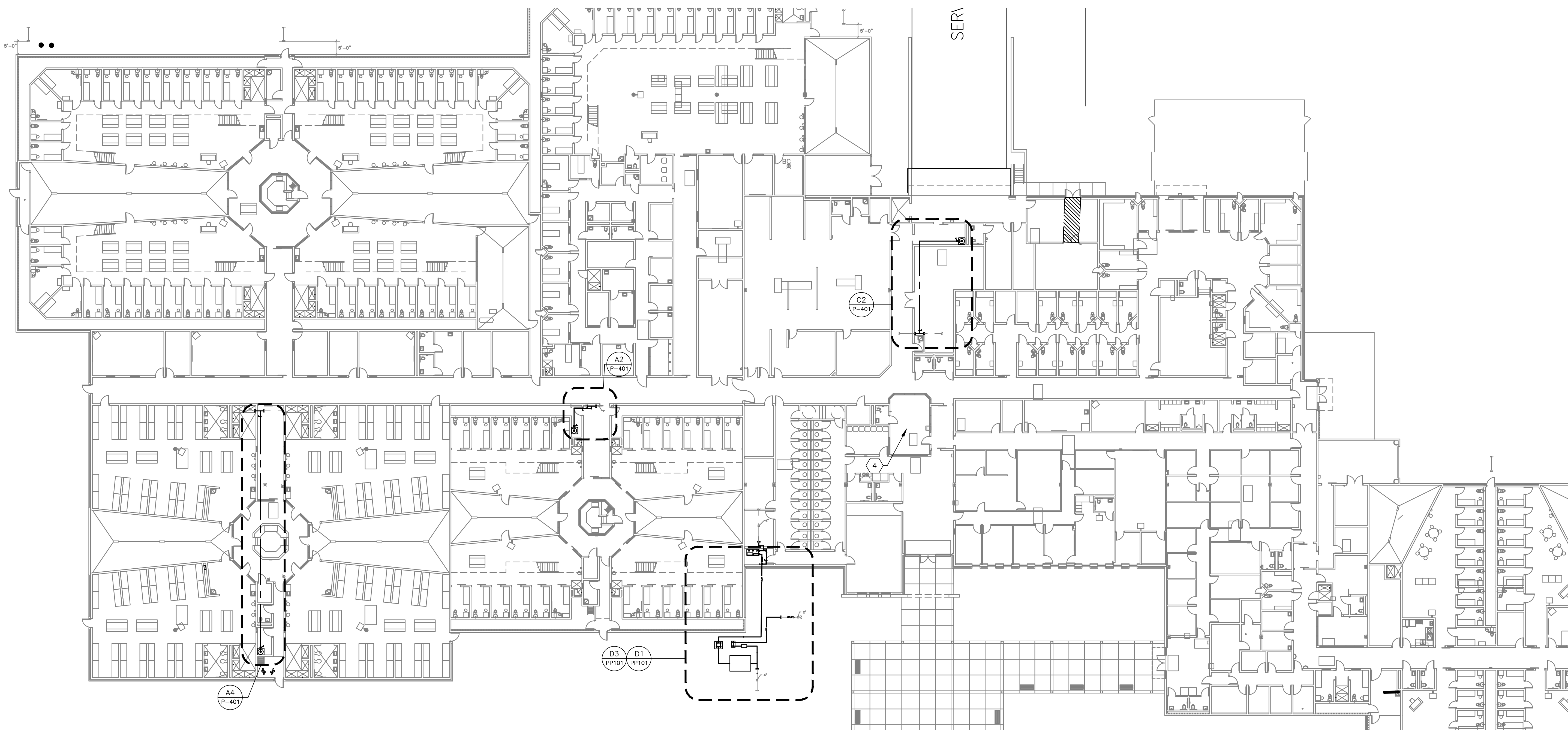

A1 LEVEL 1 - PRESSURE PIPING PLAN
SCALE: 1" = 20'-0"
0 10' 20' 40'
SCALE: 1" = 20'-0"

SHEET KEYED NOTES

1. REMOVE METER & METER PIT COMPLETE. RELOCATE METER AS SHOWN ON PLAN A1. D1/PP101
2. REMOVE BACKFLOW PREVENTER COMPLETE.
3. COORDINATE WITH PUBLIC WORKS DEPARTMENT.
4. COORDINATE WITH OWNER THE EXACT LOCATION OF EMERGENCY WATER SHUT-OFF ACTUATOR LOCATION, LABELING AND EXACT ROUTING OF CONDUIT.

GENERAL NOTES



CONSULTANTS

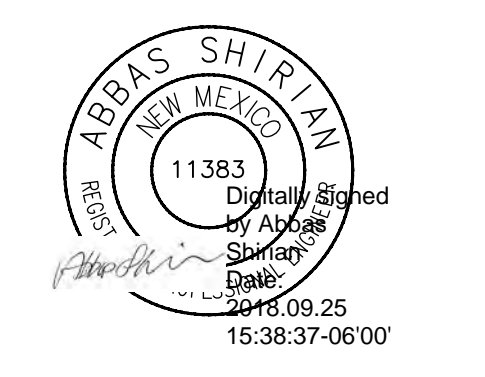

LEA COUNTY DETENTION CENTER
1401 S. Commercial St. Suite A,
Lovington, NM 88260

Domestic Booster Pump
CONSTRUCTION DOCUMENTS
SEPTEMBER 24, 2018

MARK	DATE	DESCRIPTION
PROJECT NO:	[7472.03]	
CAD FILE NAME:	747203-PP101.DWG	
DRAWN BY:	MAD	
CHK'D BY:	SDS	
SHEET TITLE		

LEVEL 1 - PRESSURE PIPING PLAN

PP101

Date: Sep 25, 2018 - 11:18am User: ACBenovidez . . . Drawing File: H:\7472.03\CAD\AutoCAD\Lea County, Detention Domestic Booster\Booster\Sheets\Plumbing\747203-P-401.dwg . . . Last Saved By: ACBenovidez Sep 24, 2018 - 3:33pm . . . Layout Name: ENLARGED PLUMBING PLANS

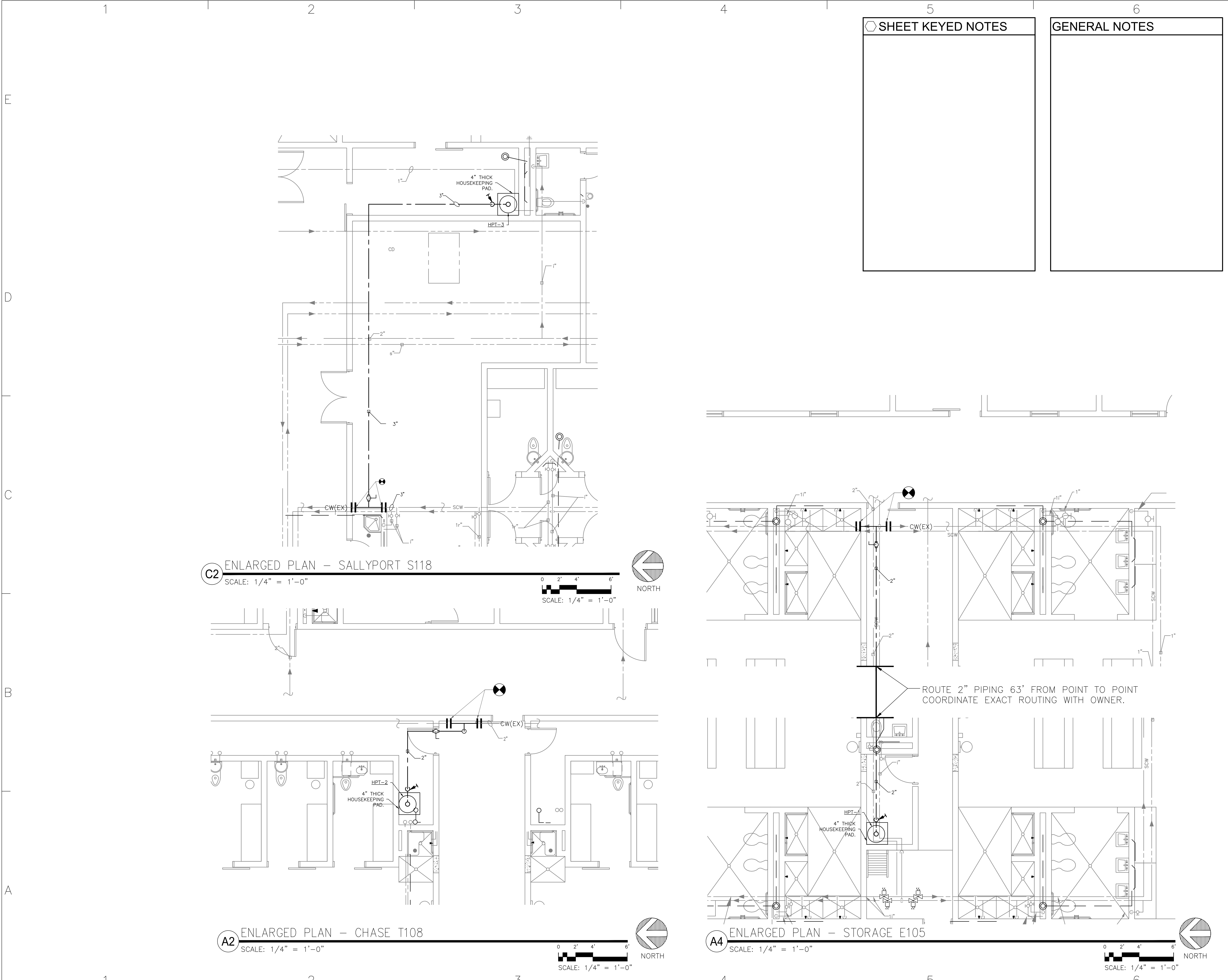

SHEET KEYED NOTES

GENERAL NOTES



CONSULTANTS

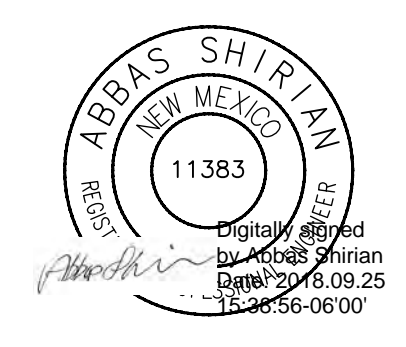

**LEA COUNTY
DETENTION
CENTER**

1401 S. Commercial St. Suite A,
Lovington, NM 88260

Domestic Booster Pump

**CONSTRUCTION
DOCUMENTS**

SEPTEMBER 24, 2018

MARK	DATE	DESCRIPTION
PROJECT NO:	[7472.03]	
CAD FILE NAME:	747203-P-401.DWG	
DRAWN BY:	MAD	
CHK'D BY:	SDS	
SHEET TITLE	ENLARGED PLUMBING PLANS	

**ENLARGED PLUMBING
PLANS**

P-401

Date: Sep 25, 2018 - 11:20am User: ACBenovidez Drawing File: H:\7472.03\CAD\AutoCAD\Lea County Detention Domestic Booster Sheets\Plumbing\747203-P-501.dwg Last Saved By: ACBenovidez Sep 24, 2018 - 3:58pm Layout Name: P-501



CONSULTANTS

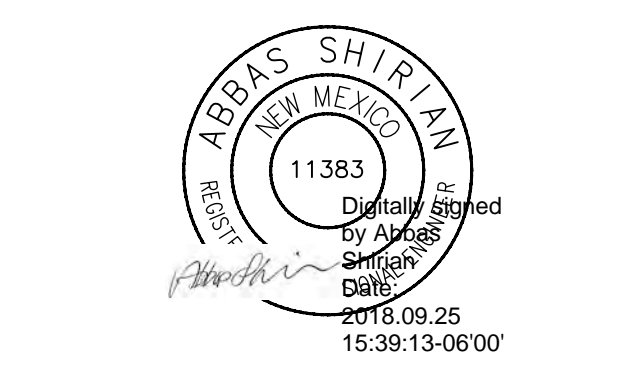

**LEA COUNTY
DETENTION
CENTER**
1401 S. Commercial St. Suite A,
Lovington, NM 88260

Domestic Booster Pump
**CONSTRUCTION
DOCUMENTS**
SEPTEMBER 24, 2018

MARK	DATE	DESCRIPTION
PROJECT NO:	[7472.03]	
CAD FILE NAME:	747203-P-501.DWG	
DRAWN BY:	MAD	
CHK'D BY:	SDS	
SHEET TITLE		

PLUMBING DETAILS

P-501

SYMBOL	MANUFACTURER	MODEL NO.	LOCATION	SERVICE	TYPE	CAPACITY (EACH PUMP)		PUMP (RPM)	MOTOR (HP EACH)	ELECTRICAL				REMARKS:		
						GPM	TOTAL FT. HD.			V	PH	HZ	AMPS		FLA	
DBP-1	HYFAB	MVP-T08G	MECH. V123	DOMESTIC COLD WATER	TRIPLEX	90	104	180	3500	5	460	3	60	-	-	TRIPLEX VFD CONTROLLED, THERMAL PROTECTION VALVES, 304 SS HEADER, PUMP ISOLATION VALVES, EPOXY COATED CHECK VALVES, SERVICE IN-PLACE CHECK VALVES, PRESSURE GAUGES, 3.5 INCH TOUCH SCREEN, NEMA 1 ENCLOSURE, NO FLOW SHUTDOWN, AUTOMATIC ALTERNATION, MANUAL OVERLOAD PROTECTION, INTERFACE WITH FMS.

SYMBOL	MANUFACTURER	MODEL NO.	LOCATION	SERVICE	NUMBER OF HEATERS	ELECTRICAL					INTERIOR DIMENSION	REMARKS:
						V	PH	HZ	WATTS	PAD SIZE		
HE-1	SAFE-T-COVER	CUSTOM	EXTERIOR	DOMESTIC WATER	1	480	1	60	3000	-	CUSTOM	ACCESS PANEL, DRAINAGE PANEL, ASSE 1060 COMPLIANT, LOCKABLE ENCLOSURE.
HE-2	SAFE-T-COVER	300TLU880-AL	EXTERIOR	IRRIGATION	1	120	1	60	500	46"X46"X6"	32W X 32L X 44T	

SYMBOL	MANUFACTURER	MODEL	LOCATION	SERVICE	TYPE	PIPE SIZE	PSI LOSS	GPM	REMARKS:
BFP-1	FEBCO	825YD	EXTERIOR	DOMESTIC	RPZ	4"	11PSI @ 150 GPM		PROVIDE LINE SIZE, HORIZONTALLY ARRANGED STRAINER WITH BLOWDOWN VALVE UPSTREAM OF EACH DEVICE, NRS VALVES.
BFP-2	FEBCO	825YD	EXTERIOR	DOMESTIC	RPZ	4"	11PSI @ 150 GPM		
BFP-3	FEBCO	LF625Y	EXTERIOR	IRRIGATION	RPZ	2"	13PSI @ 40 GPM		

SYMBOL	MANUFACTURER	MODEL NO.	SERVICE	PSI	TANK VOLUME (GAL.)	TANK DIMENSIONS	REMARKS:
HPT-1	WESSELS	FX 750V	COLD WATER	150	198	79" X 31" DIA	REPLACEABLE BLADDER TYPE, BUTYL BLADDER, SS 1-1/2" CONNECTIONS, CARBON STEEL SHELL, CHARGING VALVE CONNECTIONS, SUPPORT LEGS, LIFTING LUGS, VERTICALLY ARRANGE.
HPT-1	WESSELS	FX 750V	COLD WATER	150	198	79" X 31" DIA	
HPT-1	WESSELS	FX 750V	COLD WATER	150	198	79" X 31" DIA	

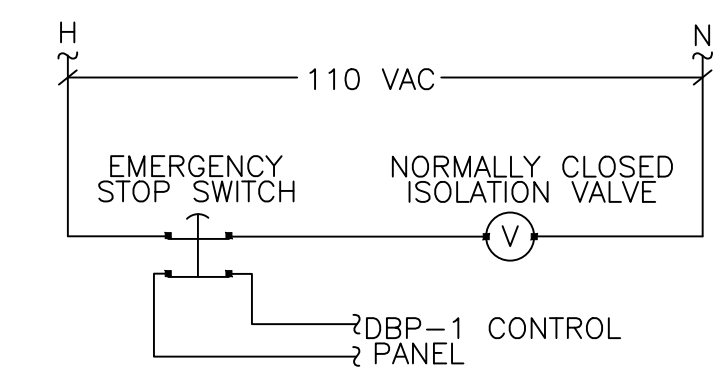

A TWO POSITION PUSH-PULL MAINTAINED EMERGENCY STOP SWITCH SHALL BE INSTALLED IN THE MAIN GUARD STATION. THE SWITCH SHALL BE CONNECTED TO THE NEW MOTORIZED ISOLATION VALVE ON DOMESTIC WATER SUPPLY LINE AND TO THE NEW BOOSTER PUMP. WHEN THE SWITCH IS IN THE NORMAL STATE, BOTH SETS OF CONTACTS SHALL BE CLOSED AND THE VALVE SHALL BE ENERGIZED OPEN AND THE BOOSTER PUMP SHALL BE ENABLED. WHEN THE SWITCH IS PRESSED, THE CONTACTS SHALL OPEN, CLOSING THE ISOLATION VALVE AND DISABLING THE BOOSTER PUMP. THE SYSTEM SHALL REMAIN IN THIS STATE UNTIL THE SWITCH IS PULLED BACK OUT RESETTING THE SYSTEM BACK TO THE NORMAL STATE.

D1 MOTORIZED ISOLATION VALVE
SCALE = NONE

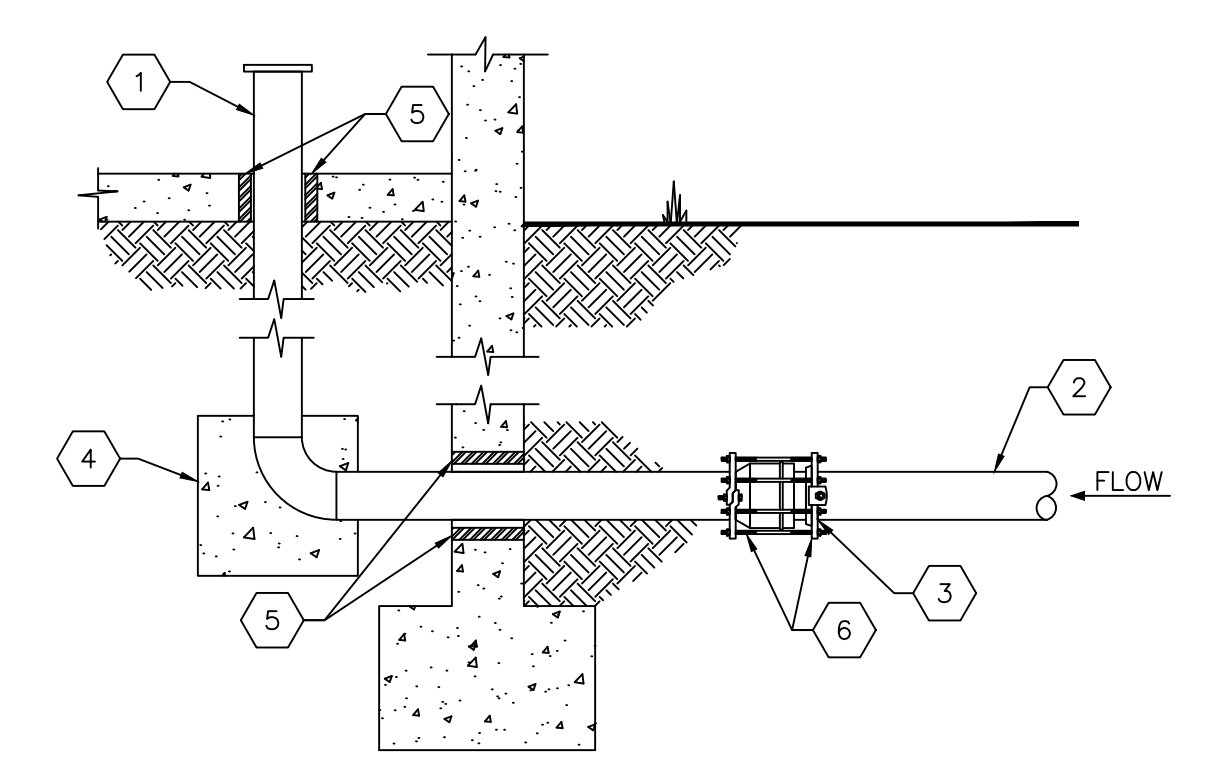

- 1 AMES IN-BUILDING RISER, STAINLESS STEEL TYPE 304. SEE PLANS FOR SIZE AND SERVICE
- 2 DUCTILE, CAST-IRON, OR PVC WATER SERVICE.
- 3 MECHANICAL JOINT FROM SUPPLY PIPE TO STAINLESS STEEL, CONTINUE INTO BUILDING WITH STAINLESS STEEL.
- 4 CONCRETE THRUST BLOCK SIZED IN ACCORDANCE WITH UBC IF REQUIRED BY AHJ
- 5 PIPE SLEEVE, SEE SPECIFICATIONS
- 6 MEGALUG PIPE RESTRAINT HARNESS

C1 WATER ENTRY THRU FOOTING DETAIL
SCALE = NONE

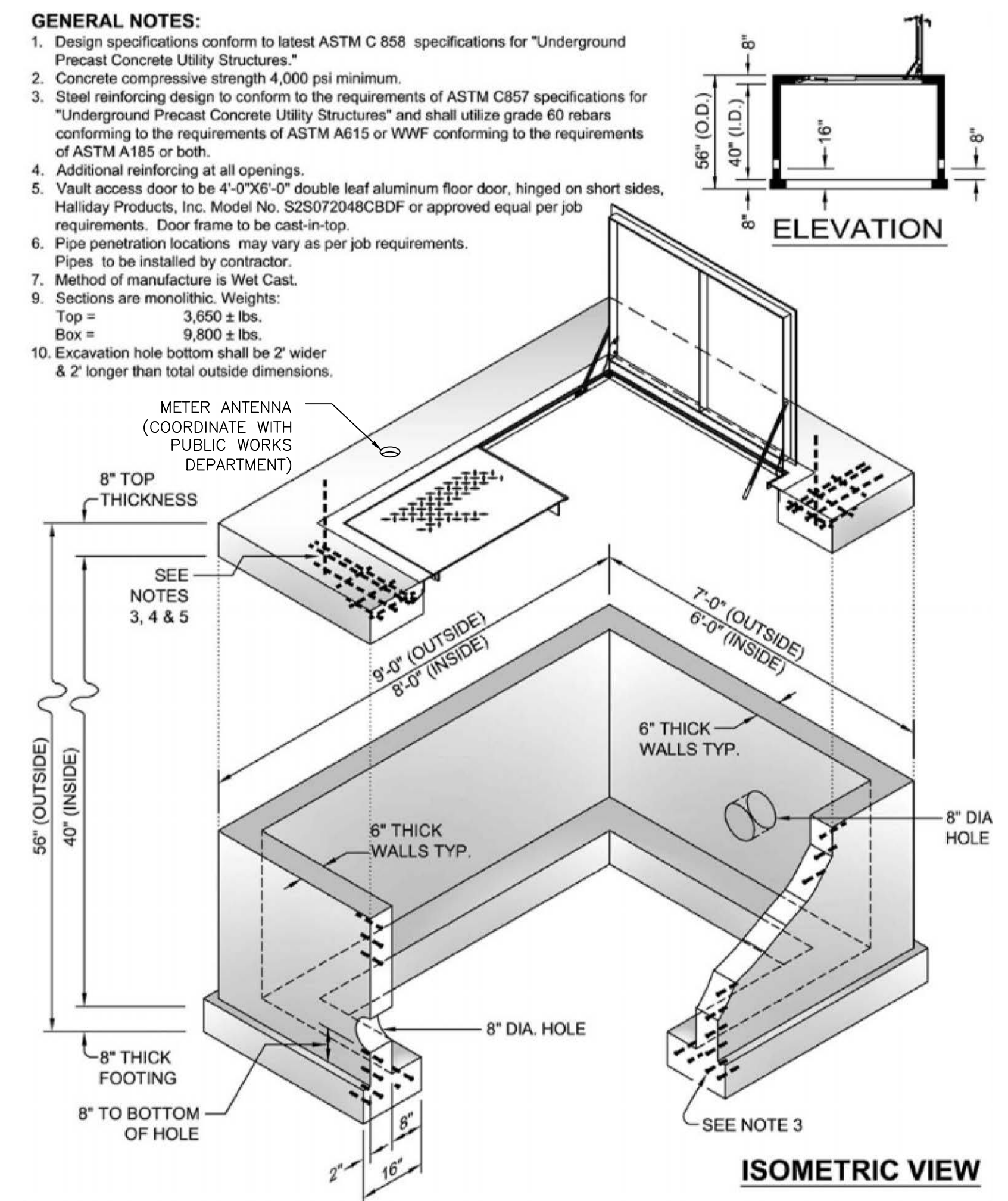

A1 6' X 8' METER BOX (4" METER BOX)
SCALE = NONE

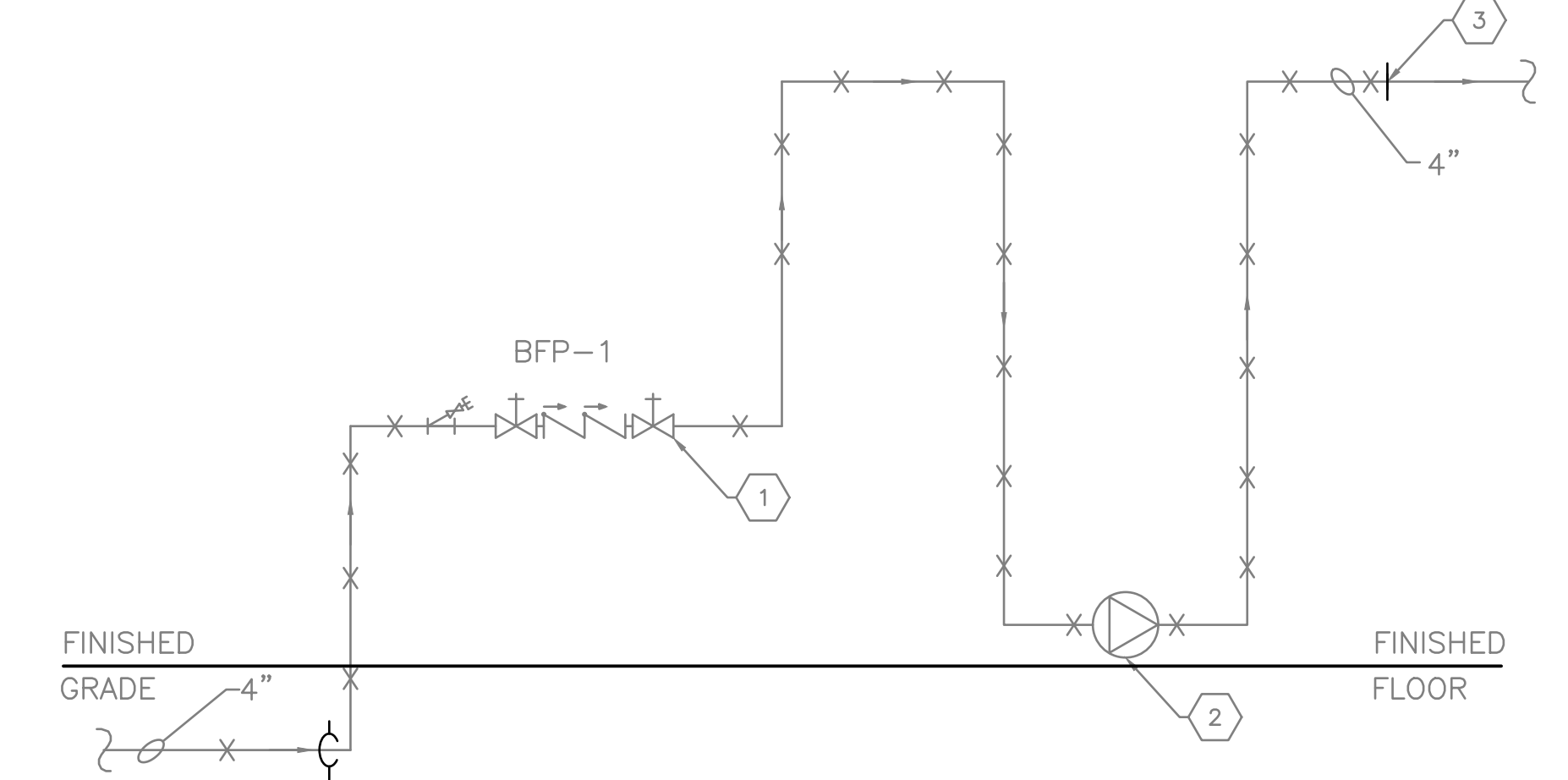

C3 DEMOLITION RISER DIAGRAM
SCALE = NONE

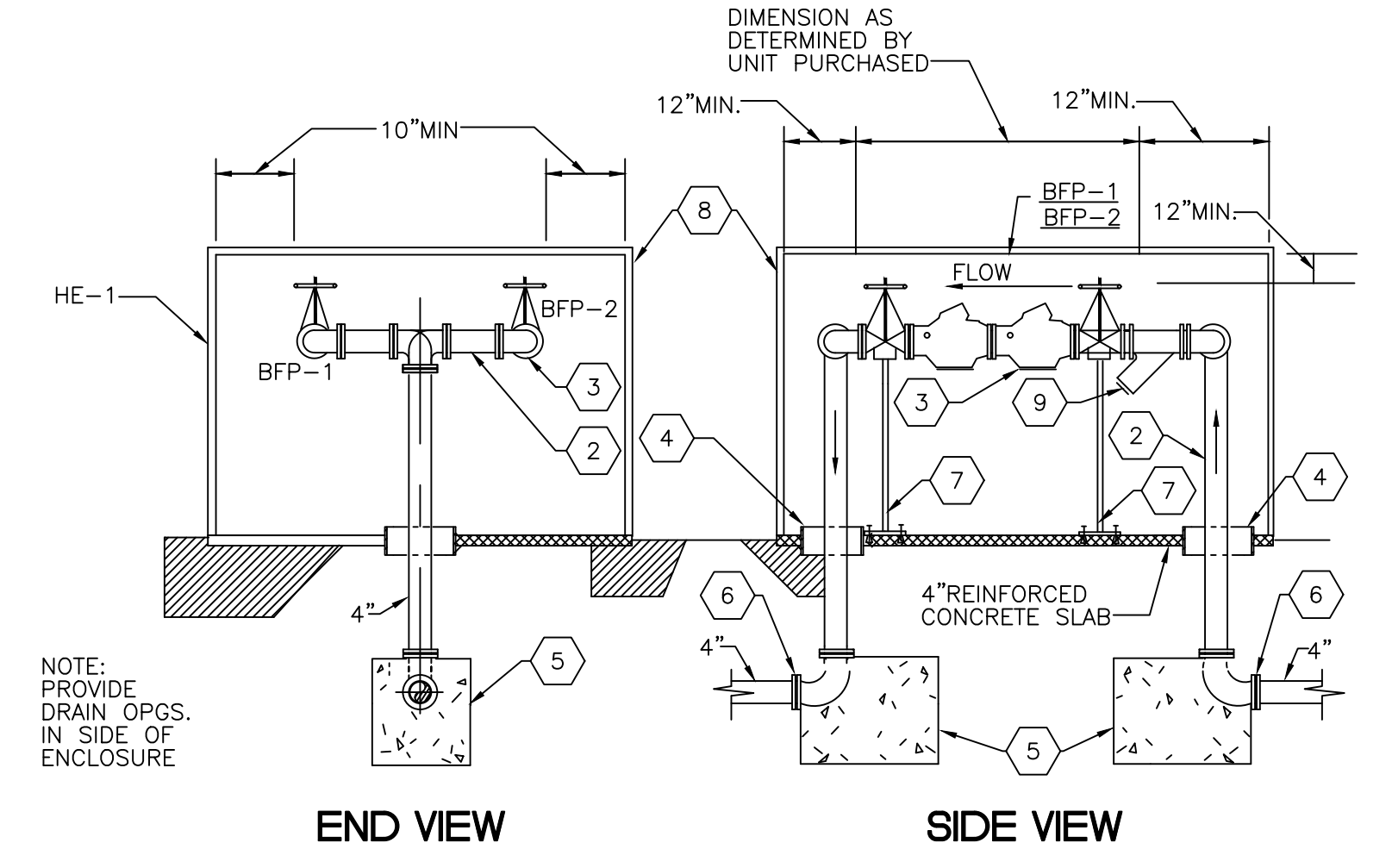

- 1 WRAP REDUCED PRESSURE BACKFLOW PREVENTOR ASSEMBLY WITH HEAT TAPE
- 2 NEW 4" PIPING AND WRAP WITH 2" INSULATION. SEE SPECIFICATIONS FOR PIPING MATERIALS
- 3 4" REDUCED PRESSURE BACKFLOW PREVENTER. DIMENSIONS FOR THIS ASSEMBLY ARE DERIVED FEBCO No. 825
- 4 SLEEVE AND CAULK SLAB PENETRATION
- 5 CONCRETE THRUST BLOCK
- 6 FURNISH NECESSARY ADAPTOR OR TRANSITION AS REQUIRED TO CONNECT TO PIPING
- 7 1" ADJUSTABLE GALVANIZED PIPE STANDS WITH RADIUSSED SADDLES. PROVIDE 8" SQ. X 1/4" THICK GALVANIZED PLATE SUPPORTS AT BASE OF STAND, SECURED AT 4 CORNERS WITH 1/4" CADMIUM PLATED EXPANSION SHIELDS AND BOLTS
- 8 PROVIDE & INSTALL ENCLOSURE AS MANUFACTURED BY HOTBOX, MODEL NO. 3, FIBERGLASS CONST., INSULATED, HINGED LID & DRAIN PORT, 21" X 69" X 34" O.A. DIMENSIONS. FURNISH WITH HEAT CABLE SUFFICIENT TO WRAP BFP ASSEMBLY & ALL EXPOSED PIPING
- 9 STRAINER WITH BLOWDOWN VALVE & HOSE CONNECTION

C5 BACKFLOW PREVENTER HOUSING DETAIL
SCALE = NONE

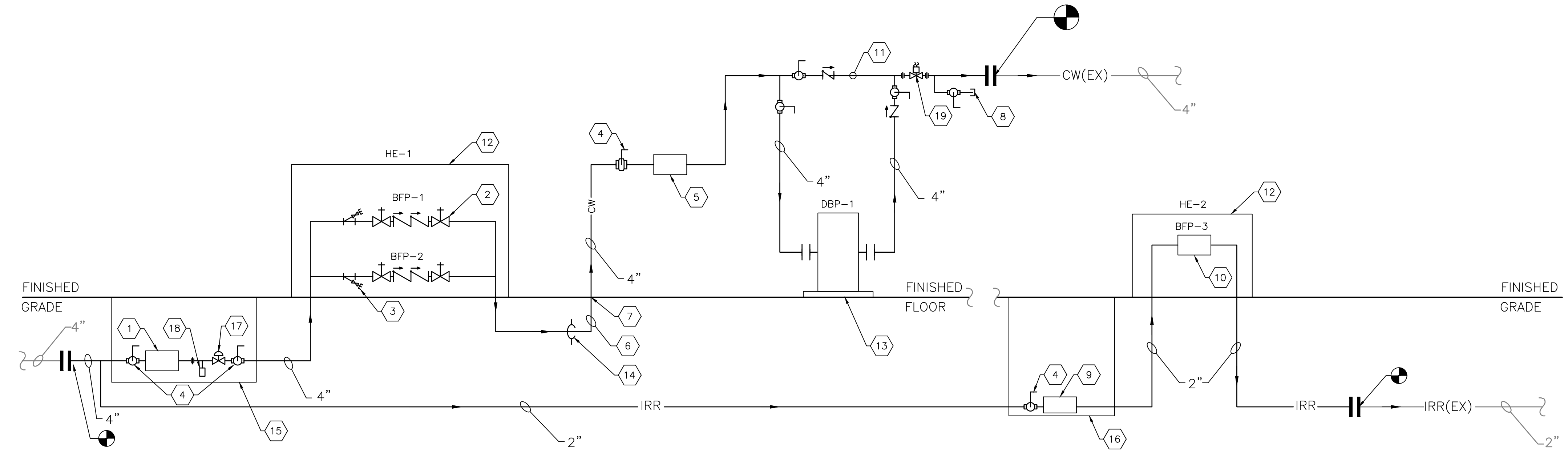

A3 NEW WORK RISER DIAGRAM
SCALE = NONE

- 1 4" DOMESTIC WATER METER
- 2 4" REDUCED PRESSURE BACKFLOW PREVENTER
- 3 STRAINER WITH BLOWDOWN VALVE & HOSE CONNECTION
- 4 ISOLATION VALVE
- 5 SUBMETER
- 6 NEW IN-BUILDING RISER, REFER TO DETAIL C1/P-501.
- 7 PATCH FLOOR SLAB TO MATCH
- 8 4" VALVE AND CAP FOR FUTURE
- 9 EXISTING IRRIGATION METER
- 10 2" REDUCED PRESSURE BACKFLOW PREVENTER (IRRIGATION)
- 11 4" CITY WATER BYPASS
- 12 HEATED ENCLOSURE, REFER TO DETAIL C5/P501
- 13 4" HOUSEKEEPING PAD, COORDINATE LOCATION WITH EXISTING FLOOR SINK AND REMOVE SINK. INSTALL NEW FLOOR SINK AS REQUIRED
- 14 BUILDING LINE
- 15 METER BOX/ VAULT
- 16 METER CAN
- 17 CITY FURNISHED PRESSURE REDUCING VALVE
- 18 PETES PLUG OR GAUGE ASSEMBLY
- 19 EMERGENCY WATER SHUT-OFF SLENOID VALVE



Consideration of Lea County Resolution No. 19-MAR-101R Approving Recommendation from the Freeholders Committee Regarding the Vacation Dedicated Right of Way (ROW) of Arizona Avenue between Blocks One and Three in Camino Del Norte Subdivision in Lea County, New Mexico.

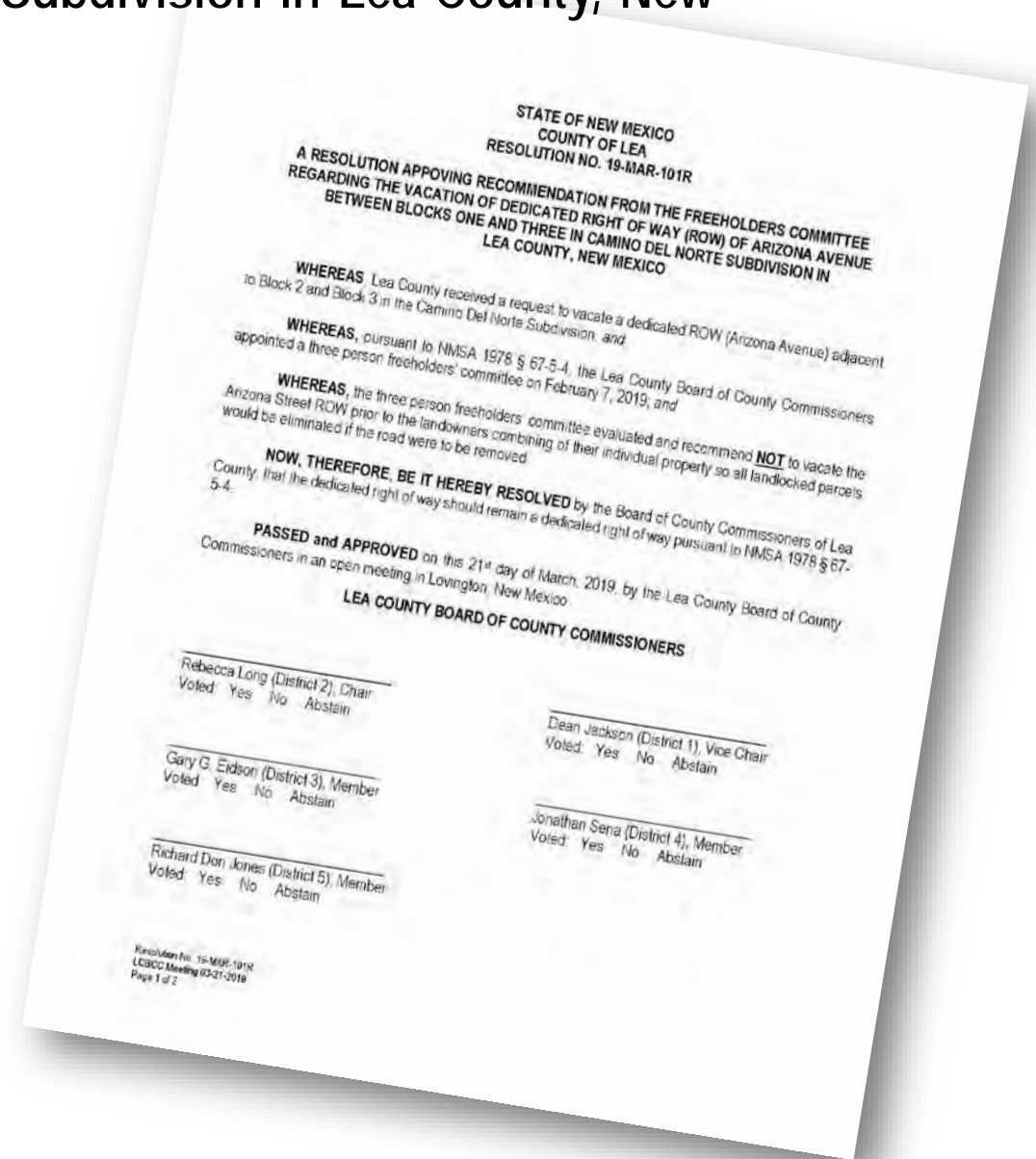

STATE OF NEW MEXICO
COUNTY OF LEA
RESOLUTION NO. 19-MAR-101R

A RESOLUTION APPROVING RECOMMENDATION FROM THE FREEHOLDERS COMMITTEE REGARDING THE VACATION OF DEDICATED RIGHT OF WAY (ROW) OF ARIZONA AVENUE BETWEEN BLOCKS ONE AND THREE IN CAMINO DEL NORTE SUBDIVISION IN LEA COUNTY, NEW MEXICO

WHEREAS Lea County received a request to vacate a dedicated ROW (Arizona Avenue) adjacent to Block 2 and Block 3 in the Camino Del Norte Subdivision; and

WHEREAS, pursuant to NMSA 1978 § 67-5-4, the Lea County Board of County Commissioners appointed a three person freeholders' committee on February 7, 2019; and

WHEREAS, the three person freeholders' committee evaluated and recommend **NOT** to vacate the Arizona Street ROW prior to the landowners combining of their individual property so all landlocked parcels would be eliminated if the road were to be removed.

NOW, THEREFORE, BE IT HEREBY RESOLVED by the Board of County Commissioners of Lea County that the dedicated right of way should remain a dedicated right of way pursuant to NMSA 1978 § 67-5-4.

PASSED and APPROVED on this 21st day of March, 2019, by the Lea County Board of County Commissioners in an open meeting in Lovington, New Mexico.

LEA COUNTY BOARD OF COUNTY COMMISSIONERS

Rebecca Long (District 2), Chair
Voted: Yes No Abstain

Dean Jackson (District 1), Vice Chair
Voted: Yes No Abstain

Gary G. Eidson (District 3), Member
Voted: Yes No Abstain

Jonathan Sena (District 4), Member
Voted: Yes No Abstain

Richard Don Jones (District 5), Member
Voted: Yes No Abstain

Consideration of Lea County Resolution No. 19-MAR-101R Approving Recommendation from the Freeholders Committee Regarding the Vacation Dedicated Right of Way (ROW) of Arizona Avenue between Blocks One and Three in Camino Del Norte Subdivision in Lea County, New Mexico.

Aerial view of existing
Arizona Avenue

Adjacent to Block 2 and Block 3
of Camino Del Norte Subdivision.



Existing Arizona Avenue in adjacent to Block 2 and Block 3 of Camino Del Norte Subdivision.





**LEA COUNTY BOARD OF COUNTY COMMISSIONERS
AGENDA ITEM SUMMARY FORM**

LCBCC Meeting Date: Thursday, March 21, 2019

Submit this summary form & all attachments to the Finance Director clow@leacounty.net & cc the Executive Coordinator ssout@leacounty.net by: **March 5, 2019**

County Manager Approval (mgallagher@leacounty.net) required for all time sensitive issues that do not meet the above deadline.

DATE SUBMITTED mm-dd-yyyy: 03/18/2019		SUBMITTED BY Name/Title/Dept: Bruce Reid County Planner Planning/GIS	
SUBJECT: Approval of recommendation from the freeholders committee to not vacate Arizona Avenue between Knowles Road and Llewellyn Street and adjacent to Blocks 2 & 3 in Camino Del Norte.		ATTACHMENT(S): Resolution Power Point	
NO. OF ORIGINALS FOR SIGNATURE: 01 Resolution 00 ***Select One** 00 ***Select One**		ACTION REQUESTED: Action Item	
STRATEGIC PLAN Implementation of 5 Year Strategic Plan:			
SUMMARY: Mr. Hollis and Mr. Medrano are requesting the vacation of Arizona Avenue adjacent to Block 2 and Block 3 and situated west of Knowles Road and east of Llewellyn Road in Camino Del Norte Subdivision. Mr. Hollis is requesting the vacate so he may place a structure on Lots 4 & 5 in Block 3 of Camino Del Norte Subdivision. He is presently unable to place a habitable structure with a liquid waste system on the property without violating Lea County Subdivision Regulation 16.4.5B paragraph 2b stating a minimum lot size for a county approved liquid waste system is one-acre of land. With the additional acreage of the vacated alleyway Mr. Hollis' land can move from 0.95 acre to 1.00+ acres, thus allowing him to place a habitable structure with a liquid waste system on his lots. Mr. Medrano join the request because he has future ideas for his land.			
Requested Items Needed for Presentation Easels/Laptop/Projector/Etc.: Easel <input type="checkbox"/> Laptop <input checked="" type="checkbox"/> Projector <input checked="" type="checkbox"/> Other: _____ <small>If checked; how many:</small>		See Additional Summary Attached <input type="checkbox"/>	
SUBMITTER'S RECOMMENDATION(S): Lea County Planning and Zoning Board Recommends Approval with a 5-0 vote. 2 members were absent.		Submitter's Signature Department Director, Etc. Bruce Reid <small>Digitally signed by Bruce Reid DN: CN=US, E=bruid@leacounty.net, O=Lea County, OU=Lea County Planning / GIS, CN=Bruce Reid Date: 2019.03.18 11:08:14-06'00'</small>	
FINANCE REVIEW Fiscal Impact/Cost:		Reviewed by Finance Director	
LEGAL REVIEW: (Note: Travel does not need legal review)		Reviewed by County Attorney	
COUNTY MANAGER REVIEW:		Approved by County Manager to be Placed on Agenda Digitally signed by Michael P. Gallagher <i>Michael P. Gallagher</i> II Date: 2019.03.19 10:17:09 -06'00'	
Item 0208 RECORDING SECRETARY'S USE ONLY ~ COMMISSION ACTION TAKEN			
Approved: _____		Denied: _____	
Resolution No. <u>19-MAR-101R</u>		Policy No. _____	
Continued To: _____		Referred To: _____	
		Other: _____	
		Ordinance No. _____	
		Comments: _____	

STATE OF NEW MEXICO
COUNTY OF LEA
RESOLUTION NO. 19-MAR-101R

A RESOLUTION APPROVING RECOMMENDATION FROM THE FREEHOLDERS COMMITTEE
REGARDING THE VACATION OF DEDICATED RIGHT OF WAY (ROW) OF ARIZONA AVENUE
BETWEEN BLOCKS ONE AND THREE IN CAMINO DEL NORTE SUBDIVISION IN
LEA COUNTY, NEW MEXICO

WHEREAS, Lea County received a request to vacate a dedicated ROW (Arizona Avenue) adjacent to Block 2 and Block 3 in the Camino Del Norte Subdivision; *and*

WHEREAS, pursuant to NMSA 1978 § 67-5-4, the Lea County Board of County Commissioners appointed a three person freeholders' committee on February 7, 2019; *and*

WHEREAS, the three person freeholders' committee evaluated and recommend **NOT** to vacate the Arizona Street ROW prior to the landowners combining of their individual property so all landlocked parcels would be eliminated if the road were to be removed.

NOW, THEREFORE, BE IT HEREBY RESOLVED by the Board of County Commissioners of Lea County, that the dedicated right of way should remain a dedicated right of way pursuant to NMSA 1978 § 67-5-4.

PASSED and APPROVED on this 21st day of March, 2019, by the Lea County Board of County Commissioners in an open meeting in Lovington, New Mexico.

LEA COUNTY BOARD OF COUNTY COMMISSIONERS

Rebecca Long (District 2), Chair
Voted: Yes No Abstain

Dean Jackson (District 1), Vice Chair
Voted: Yes No Abstain

Gary G. Eidson (District 3), Member
Voted: Yes No Abstain

Jonathan Sena (District 4), Member
Voted: Yes No Abstain

Richard Don Jones (District 5), Member
Voted: Yes No Abstain

ATTEST: Keith Manes
Lea County Clerk

**APPROVED AS TO FORM AND LEGAL
SUFFICIENCY:**

By: _____
Kelli Williams, Deputy Clerk

John W. Caldwell, County Attorney



BUDGET ADJUSTMENT #2
Resolution 19-MAR-102R

SUMMARY OF ADJUSTMENTS

	Revenue	Expense	Net Effect	Transfers	Budget Adj. 18-DEC-xxxR	% Inc. (Dec). In Budgeted Exp
GENERAL FUND (unrestricted)	-	319,066	(319,066)	-	32,891,945	0.97%
ROAD FUND	-	-	-	-	13,474,432	0.00%
SPECIAL REV FUNDS (restricted)	885,175	985,175	(100,000)	20,000.00	47,468,550	2.08%
CAPITAL PROJECTS FUND	-	-	-	-	44,267,971	0.00%
PROPRIETARY FUND	-	-	-	-	10,341,255	0.00%
TRUST & AGENCY (restricted)	140,000	140,000	-	-	7,312,652	1.91%
Total	1,025,175	1,444,241	(419,066)	20,000	155,756,805	0.93%



**LEA COUNTY BOARD OF COUNTY COMMISSIONERS
AGENDA ITEM SUMMARY FORM**

LCBCC Meeting Date: Thursday, March 21, 2019

Submit this summary form & all attachments to the Finance Director clow@leacounty.net & cc the Executive Coordinator sstout@leacounty.net by: **March 5, 2019**

County Manager Approval (mgallagher@leacounty.net) required for all time sensitive issues that do not meet the above deadline.

DATE SUBMITTED mm-dd-yyyy: 03/15/2019		SUBMITTED BY Name/Title/Dept: Chip Low - Finance Director	
SUBJECT: Lea County FY19 Budget Adjustments #2		ATTACHMENT(S): 1. Budget Adjustments Worksheet #2 2. Budget Adjustments Resolution	
NO. OF ORIGINALS FOR SIGNATURE: 01 Resolution 00 ***Select One** 00 ***Select One**		ACTION REQUESTED: Action Item	
STRATEGIC PLAN Implementation of 5 Year Strategic Plan: The information in the financial report meets the goals in Section 3.1 on Accountability which is "Lea County is responsible for the public's tax dollars in a fiscally conservative and transparent manner". Performance measures that apply are 3.1.1, 3.1.2, 3.1.4 and 3.1.5.			
SUMMARY: The overall impact to Lea County will be an increase in expenditures over revenues of \$419,066. Cash reserves are available to meet the additional expenditures.			
Requested Items Needed for Presentation Easels/Laptop/Projector/Etc.: Easel <input type="checkbox"/> Laptop <input checked="" type="checkbox"/> Projector <input checked="" type="checkbox"/> Other:			See Additional Summary Attached <input type="checkbox"/>
SUBMITTER'S RECOMMENDATION(S): Recommend approval		Submitter's Signature Department Director, Etc. Henry C Low Jr <small>Digitally signed by Henry C Low Jr Date: 2019.03.15 13:57:09 -06'00'</small>	
FINANCE REVIEW Fiscal Impact/Cost: The financial impact to Lea County will be a decrease in cash budgeted of \$419,066. Cash reserves are available to meet the additional expenditures.		Reviewed by Finance Director Henry C Low Jr <small>Digitally signed by Henry C Low Jr Date: 2019.03.15 13:58:34 -06'00'</small>	
LEGAL REVIEW: (Note: Travel does not need legal review)		Reviewed by County Attorney	
COUNTY MANAGER REVIEW:		Approved by County Manager to be Placed on Agenda <small>Digitally signed by Michael P. Gallagher</small> <small>Date: 2019.03.20 14:11:59 -06'00'</small>	
Item 0209 RECORDING SECRETARY'S USE ONLY ~ COMMISSION ACTION TAKEN			
Approved: _____ Resolution No. <u>19-MAR-102R</u> Continued To: _____		Denied: _____ Policy No. _____ Referred To: _____	
		Other: _____ Ordinance No. _____ Comments: _____	

STATE OF NEW MEXICO
COUNTY OF LEA
RESOLUTION NO. 19-MAR-102R

A RESOLUTION APPROVING BUDGET ADJUSTMENT NO. 02 FOR
LEA COUNTY'S FISCAL YEAR 2018 - 2019

WHEREAS, the Board of County Commissioners of Lea County, of the State of New Mexico, needs to adjust the current approved budget for fiscal year 2018 - 2019; *and*

WHEREAS, said budget was adjusted on the basis of need and through cooperation with all user departments, elected officials and other department supervisors; *and*

WHEREAS, it is the majority opinion of this Board that the adjusted budget meets the requirements as currently determined for fiscal year 2018 - 2019.

NOW, THEREFORE, BE IT HEREBY RESOLVED, that the Board of County Commissioners of Lea County, of the State of New Mexico, hereby adopts the budget adjustments hereinabove described and attached and respectfully requests approval from the State of New Mexico Department of Finance and Administration Local Government Division.

PASSED, APPROVED AND ADOPTED on this 21st day of March, 2019, by the Lea County Board of County Commissioners in an open meeting in Lovington, New Mexico.

LEA COUNTY BOARD OF COUNTY COMMISSIONERS

Rebecca Long (District 2), Chair
Voted: Yes No Abstain

Dean Jackson (District 1), Vice Chair
Voted: Yes No Abstain

Gary G. Eidson (District 3), Member
Voted: Yes No Abstain

Jonathan Sena (District 4), Member
Voted: Yes No Abstain

Richard Don Jones (District 5), Member
Voted: Yes No Abstain

ATTEST: Keith Manes
Lea County Clerk

**APPROVED AS TO FORM AND LEGAL
SUFFICIENCY:**

By: _____
Kelli Williams, Deputy Clerk

John W. Caldwell, County Attorney

BUDGET ADJUSTMENT #2
Resolution No. 19-MAR-102R

SUMMARY OF BUDGET ADJUSTMENTS TO DATE FOR FY 2018 - 2019

REVENUE ADJUSTMENTS	Approved Budget	Budget Adj 18- DEC-xxxR	Budget Adj. 19- MAR-xxxR						Total
GENERAL FUND (unrestricted)	57,567,197	1,208,915	-	-	-	-	-	-	58,776,112
ROAD FUND	1,823,980	-	-	-	-	-	-	-	1,823,980
SPECIAL REV FUNDS (restricted)	17,818,288	926,172	885,175	-	-	-	-	-	19,629,635
CAPITAL PROJECTS FUND	3,100,000	-	-	-	-	-	-	-	3,100,000
ENTERPRISE FUNDS	4,744,414	-	-	-	-	-	-	-	4,744,414
TRUST & AGENCY (restricted)	7,756,282	75,000	140,000	-	-	-	-	-	7,971,282
Total	92,810,161	2,210,087	1,025,175	-	-	-	-	-	96,045,423

EXPENDITURE ADJUSTMENTS	Approved Budget	Budget Adj 18- DEC-xxxR							Total
GENERAL FUND (unrestricted)	31,363,964	1,208,915	319,066	-	-	-	-	-	32,891,945
ROAD FUND	13,474,432	-	-	-	-	-	-	-	13,474,432
SPECIAL REV FUNDS (restricted)	45,874,756	608,619	985,175	-	-	-	-	-	47,468,550
CAPITAL PROJECTS FUND	42,314,468	1,953,503	-	-	-	-	-	-	44,267,971
PROPRIETARY FUND	10,541,255	(200,000)	-	-	-	-	-	-	10,341,255
TRUST & AGENCY (restricted)	7,123,197	49,455	140,000	-	-	-	-	-	7,312,652
Total	150,692,072	3,620,492	1,444,241	-	-	-	-	-	155,756,805

NET EFFECT CASH	Cash Effect per Resolution								
GENERAL FUND (unrestricted)	26,203,233	-	(319,066)	-	-	-	-	-	25,884,167
ROAD FUND	(11,650,452)	-	-	-	-	-	-	-	(11,650,452)
SPECIAL REVFUNDS (restricted)	(28,056,468)	317,553	(100,000)	-	-	-	-	-	(27,838,915)
CAPITAL PROJECTS FUND	(39,214,468)	(1,953,503)	-	-	-	-	-	-	(41,167,971)
PROPRIETARY FUND	(5,796,841)	200,000	-	-	-	-	-	-	(5,596,841)
TRUST & AGENCY (restricted)	633,085	25,545	-	-	-	-	-	-	658,630
	(57,881,911)	(1,410,405)	(419,066)	-	-	-	-	-	(59,711,382)

1. County Operations

Department	Line Item Description	Fund	Dept	Line	Current Budget	Current Expended	% Used	Proposed Adjustment	Adjusted Line Item Budget	Justification
County Operations	Audit	401	00	2062	59,451	59,763	100.5%	312	59,763	CABQ tax increase
County Operations	Code Red Program	401	00	2250	24,000	21,422	89.3%	(312)	23,688	Reallocation
Increase (Decrease) in budgeted expenditures								-		

2. County Executive

Department	Line Item Description	Fund	Dept	Line	Current Budget	Current Expended	% Used	Proposed Adjustment	Adjusted Line Item Budget	Justification
County Executive	Full-Time Positions	401	01	2002	480,082	339,623	70.7%	7,700	487,782	Contract Renewal
County Executive	Vacation & Sick Leave	401	01	2208	5,500	-	0.0%	247,652	253,152	Contract Renewal
County Executive	Contract Severance	401	01	2103	440,705	-	0.0%	(51,096)	389,609	Contract Renewal
County Executive	FICA/Medicare	401	01	2064	35,772	16,612	46.4%	19,535	55,307	Contract Renewal
Sheriff's Department	PERA	401	01	2063	48,454	32,530	67.1%	1,146	49,600	Contract Renewal
Sheriff's Department	Retiree Health Insurance	401	01	2200	13,682	6,233	45.6%	220	13,902	Contract Renewal
Increase (Decrease) in budgeted expenditures								225,157		

3. Sheriff's Department

Department	Line Item Description	Fund	Dept	Line	Current Budget	Current Expended	% Used	Proposed Adjustment	Adjusted Line Item Budget	Justification
Sheriff's Department	Overtime	401	08	2005	778,000	719,652	92.5%	250,000	1,028,000	Reallocation
Sheriff's Department	Full-Time Positions	401	08	2002	5,180,303	3,094,915	59.7%	(250,000)	4,930,303	Reallocation
Sheriff's Department	Contractual Serv - Maintenance	401	08	2079	48,947	32,432	66.3%	3,979	52,926	Reallocation
Sheriff's Department	Maintenance	401	08	2012	50,000	24,544	49.1%	(3,979)	46,021	Reallocation
Increase (Decrease) in budgeted expenditures								-		

4. Probate Judge

Department	Line Item Description	Fund	Dept	Line	Current Budget	Current Expended	% Used	Proposed Adjustment	Adjusted Line Item Budget	Justification
Probate Judge	Travel/PerDiem	401	09	2010	1,700	2,583	151.9%	884	2,584	Reallocation
Probate Judge	Office Supplies	401	09	2009	1,500	160	10.7%	(884)	616	Reallocation
Increase (Decrease) in budgeted expenditures								-		

5. Legal

Department	Line Item Description	Fund	Dept	Line	Current Budget	Current Expended	% Used	Proposed Adjustment	Adjusted Line Item Budget	Justification
Legal	Full-Time Positions	401	24	2002	188,842	130,280	69.0%	1,600	190,442	Contract Renewal
Legal	Vacation & Sick Pay	401	24	2208	-	-	0.0%	110,369	110,369	Contract Renewal
Legal	Contract Severance	401	24	2103	150,432	-	0.0%	(26,910)	123,522	Contract Renewal
Legal	FICA/Medicare	401	24	2064	10,798	6,435	59.6%	8,566	19,364	Contract Renewal
Legal	PERA	401	24	2063	27,335	18,366	67.2%	238	27,573	Contract Renewal
Legal	Retiree Health Care	401	24	2200	5,382	3,519	65.4%	46	5,428	Contract Renewal
Increase (Decrease) in budgeted expenditures								93,909		

6 Finance

Department	Line Item Description	Fund	Dept	Line	Current Budget	Current Expended	% Used	Proposed Adjustment	Adjusted Line Item Budget	Justification
Finance	Overtime	401	75	2005	2,000	4,491	224.5%	5,000	7,000	Reallocation
Finance	Full-Time Position	401	75	2002	552,842	355,343	64.3%	(5,000)	547,842	Reallocation
Increase (Decrease) in budgeted expenditures								-		

7. Emergency Management

Department	Line Item Description	Fund	Dept	Line	Current Budget	Current Expended	% Used	Proposed Adjustment	Adjusted Line Item Budget	Justification
Emergency Management	Vacation	401	77	2208	2,000	7,197	359.9%	5,600	7,600	Reallocation
Emergency Management	Full-Time Position	401	77	2002	151,969	85,906	56.5%	(5,600)	146,369	Reallocation
Increase (Decrease) in budgeted expenditures								-		

Total proposed Revenue Adjustments:	-
Less:	
Total proposed Expenditure Adjustments:	319,066
Net Effect on Budgeted Cash Position	(319,066)

8. Indigent GRT

Department	Line Item Description	Fund	Dept	Line	Current Budget	Current Expended	% Used	Proposed Adjustment	Adjusted Line Item Budget	Justification
Indigent GRT	Administrative Fee	406	13	2207		190,089	0.0%	313,648	313,648	DFA required reporting
	Increase (Decrease) in budgeted expenditures							313,648		

Indigent GRT										
Department	Line Item Description	Fund	Dept	Line	Current Budget	Current Revenue	% Received	Proposed Adjustment	Adjusted Line Item Budget	Justification
Indigent GRT	GRT Revenue	406	00	1410	5,329,010	5,849,988	109.8%	313,648	5,642,658	DFA required reporting
	Increase (Decrease) in budgeted revenue							313,648		

9. Maljamar Fire Department

Department	Line Item Description	Fund	Dept	Line	Current Budget	Current Expended	% Used	Proposed Adjustment	Adjusted Line Item Budget	Justification
Maljamar Fire Department	Equipment Operating	407	14	2076	58,612	35,975	61.4%	36,038	94,650	Budget increase
	Increase (Decrease) in budgeted expenditures							36,038		

Maljamar Fire Department										
Department	Line Item Description	Fund	Dept	Line	Current Budget	Current Revenue	% Received	Proposed Adjustment	Adjusted Line Item Budget	Justification
Maljamar Fire Department	State Grant	407	00	1490	-	36,038	0.0%	36,038	36,038	Grant Funding
	Increase (Decrease) in budgeted revenue							36,038		

10. Knowles Fire Department

Department	Line Item Description	Fund	Dept	Line	Current Budget	Current Expended	% Used	Proposed Adjustment	Adjusted Line Item Budget	Justification
Knowles Fire Department	Equipment Operating	408	15	2076	63,882	34,666	54.3%	61,213	125,095	Grant Funding
	Increase (Decrease) in budgeted expenditures							61,213		

Knowles Fire Department										
Department	Line Item Description	Fund	Dept	Line	Current Budget	Current Revenue	% Received	Proposed Adjustment	Adjusted Line Item Budget	Justification
Knowles Fire Department	State Grant	408	00	1490	-	61,213	0.0%	61,213	61,213	Grant Funding
	Increase (Decrease) in budgeted revenue							61,213		

11. Environmental Services

Department	Line Item Description	Fund	Dept	Line	Current Budget	Current Expended	% Used	Proposed Adjustment	Adjusted Line Item Budget	Justification
Environmental Services	Administrative Fee	411	27	2207		97,350	0.0%	160,628	160,628	DFA required reporting
	Increase (Decrease) in budgeted expenditures							160,628		

Environmental Services										
Department	Line Item Description	Fund	Dept	Line	Current Budget	Current Revenue	% Received	Proposed Adjustment	Adjusted Line Item Budget	Justification
Environmental Services	GRT Revenue	411	00	1410	2,160,000	2,993,230	138.6%	160,628	2,320,628	DFA required reporting
	Increase (Decrease) in budgeted revenue							160,628		

12. Detention Center

Department	Line Item Description	Fund	Dept	Line	Current Budget	Current Expended	% Used	Proposed Adjustment	Adjusted Line Item Budget	Justification
Detention	Washers	418	23	4749	41,188	-	0.0%	6,799	47,987	Budget increase
	Increase (Decrease) in budgeted expenditures							6,799		

13. Capital Projects

Department	Line Item Description	Fund	Dept	Line	Current Budget	Current Expended	% Used	Proposed Adjustment	Adjusted Line Item Budget	Justification
Detention	Building Improvements	430	00	4778	1,526,970	156,169	10.2%	(76,799)	1,450,171	Reallocation
	Increase (Decrease) in budgeted expenditures							(76,799)		

14. Misdemeanor Compliance

Department	Line Item Description	Fund	Dept	Line	Current Budget	Current Expended	% Used	Proposed Adjustment	Adjusted Line Item Budget	Justification
Misdemeanor Compliance	Health Insurance	439	81	2016	10,146	10,880	107.2%	6,254	16,400	Reallocation
Misdemeanor Compliance		439	81	2605	30,000	10,026	33.4%	(6,254)	23,746	Reallocation
	Increase (Decrease) in budgeted expenditures							-		

15. Lea Regional Airport

Department	Line Item Description	Fund	Dept	Line	Current Budget	Current Expended	% Used	Proposed Adjustment	Adjusted Line Item Budget	Justification
Lea Regional Airport	Terminal Reconstruction-Hobbs	454	18	4209	5,173,946	301,126	5.8%	100,000	5,273,946	Contracted amounts
	Increase (Decrease) in budgeted expenditures							100,000		

Lea Regional Airport
Cash balance of \$124,212 available to fund the increase.

16. Lovington Airport

Department	Line Item Description	Fund	Dept	Line	Current Budget	Current Expended	% Used	Proposed Adjustment	Adjusted Line Item Budget	Justification
Lovington Airport	Utilities	455	18	2025	6,000	6,445	107.4%	3,000	9,000	
	Increase (Decrease) in budgeted expenditures							3,000		

17. Jal Airport

Department	Line Item Description	Fund	Dept	Line	Current Budget	Current Expended	% Used	Proposed Adjustment	Adjusted Line Item Budget	Justification
Jal Airport	Utilities	456	18	2025	6,000	1,806	30.1%	(3,000)	3,000	
	Increase (Decrease) in budgeted expenditures							(3,000)		

18. Fair and Rodeo

Department	Line Item Description	Fund	Dept	Line	Current Budget	Current Expended	% Used	Proposed Adjustment	Adjusted Line Item Budget	Justification
Fair and Rodeo	Overtime	461	33	2005	75,556	82,482	109.2%	6,927	82,483	Reallocation
Fair and Rodeo	Full time Position	461	33	2002	36,426	24,278	66.7%	(5,273)	31,153	Reallocation
	Increase (Decrease) in budgeted expenditures							1,654		

19. Hispanic Heritage Night

Department	Line Item Description	Fund	Dept	Line	Current Budget	Current Expended	% Used	Proposed Adjustment	Adjusted Line Item Budget	Justification
Hispanic Heritage Night	Overtime	462	34	2005	9,444	7,790	82.5%	(1,654)	7,790	Reallocation
Hispanic Heritage Night	Travel/Per diem	462	34	2010	1,000	-	0.0%	(1,000)	-	Reallocation
Hispanic Heritage Night	Rental of Equipment	462	34	2013	2,000	-	0.0%	(2,000)	-	Reallocation
Hispanic Heritage Night	Advertising	462	34	2027	11,000	11,842	107.7%	2,000	13,000	Reallocation
Hispanic Heritage Night	Queen	462	34	2502	3,000	3,308	110.3%	1,000	4,000	Reallocation
	Increase (Decrease) in budgeted expenditures							(1,654)		

20. Event Center

Department	Line Item Description	Fund	Dept	Line	Current Budget	Current Expended	% Used	Proposed Adjustment	Adjusted Line Item Budget	Justification
Event Center	Non Capital Equipment	463	31	2232	36,000	-	0.0%	(11,000)	25,000	Reallocation
Event Center	Equipment	463	31	4367	42,500	499	1.2%	11,000	53,500	Reallocation
Event Center	Event Center Improvements	463	31	4557	146,497	72,099	49.2%	70,000	216,497	Reallocation
Increase (Decrease) in budgeted expenditures								70,000		

21. Debt Services

Department	Line Item Description	Fund	Dept	Line	Current Budget	Current Expended	% Used	Proposed Adjustment	Adjusted Line Item Budget	Justification
Debt Services	Administrative Fee	658	58	2207		190,089	0.0%	313,648	313,648	DFA required reporting
Increase (Decrease) in budgeted expenditures								313,648		

Debt Services										
Department	Line Item Description	Fund	Dept	Line	Current Budget	Current Revenue	% Received	Proposed Adjustment	Adjusted Line Item Budget	Justification
Debt Services	GRT Revenue	658	00	1800	4,920,000	5,849,988	118.9%	313,648	5,233,648	DFA required reporting
Increase (Decrease) in budgeted revenue								313,648		

22. Trust Agency

Department	Line Item Description	Fund	Dept	Line	Current Budget	Current Expended	% Used	Proposed Adjustment	Adjusted Line Item Budget	Justification
Trust Agency	Gross Receipts Tax	800	70	2121	150,000	153,875	102.6%	80,000	230,000	Higher sales
Trust Agency	Junior Livestock Sale	800	70	2330	490,000	524,778	107.1%	60,000	550,000	Higher sales
Increase (Decrease) in budgeted expenditures								140,000		

Trust Agency										
Department	Line Item Description	Fund	Dept	Line	Current Budget	Current Revenue	% Received	Proposed Adjustment	Adjusted Line Item Budget	Justification
Trust Agency	GRT Revenue	800	00	1324	150,000	128,604	85.7%	80,000	230,000	Higher sales
Debt Services	GRT Revenue	800	00	1901	490,000	534,938	109.2%	60,000	550,000	Higher sales
Increase (Decrease) in budgeted revenue								140,000		

23. Lea County Communications Authority

Department	Line Item Description	Fund	Dept	Line	Current Budget	Current Expended	% Used	Proposed Adjustment	Adjusted Line Item Budget	Justification
LC Communication Authority	Contractual Serv Physicals	808	78	2086	5,000	6,356	127.1%	1,000	6,000	Reallocation
LC Communication Authority	Vacation	808	78	2208	20,000	20,296	101.5%	2,500	22,500	Reallocation
LC Communication Authority	Overtime	808	78	2005	200,000	180,334	90.2%	60,000	260,000	Reallocation
LC Communication Authority	Full time Positions	808	78	2002	1,318,958	846,709	64.2%	(60,000)	1,258,958	Reallocation
LC Communication Authority	Printing and Publishing	808	78	2008	2,000	1,376	68.8%	1,000	3,000	Reallocation
LC Communication Authority	office supplies	808	78	2009	25,000	12,895	51.6%	(1,000)	24,000	Reallocation
LC Communication Authority	Contractual Service Maintenance	808	78	2079	25,000	16,081	64.3%	1,244	26,244	Reallocation
LC Communication Authority	Education/Registration/Dues	808	78	2016	30,000	6,649	22.2%	(4,744)	25,256	Reallocation
Increase (Decrease) in budgeted expenditures									-	

Total proposed Revenue Adjustments:	1,025,175
Less:	
Total proposed Expenditure Adjustments:	1,125,175
Net Effect on Budgeted Cash Position	(100,000)

BUDGET ADJUSTMENT #2
Resolution 19-MAR-102R

SUMMARY OF ADJUSTMENTS

	Revenue	Expense	Net Effect	Transfers	Budget Adj. 18- DEC-xxxR	% Inc. (Dec). In Budgeted Exp
GENERAL FUND (unrestricted)	-	319,066	(319,066)	-	32,891,945	0.97%
ROAD FUND	-	-	-	-	13,474,432	0.00%
SPECIAL REV FUNDS (restricted)	885,175	985,175	(100,000)	20,000.00	47,468,550	2.08%
CAPITAL PROJECTS FUND	-	-	-	-	44,267,971	0.00%
PROPRIETARY FUND	-	-	-	-	10,341,255	0.00%
TRUST & AGENCY (restricted)	140,000	140,000	-	-	7,312,652	1.91%
Total	1,025,175	1,444,241	(419,066)	20,000	155,756,805	0.93%

BUDGET ADJUSTMENT #2
Resolution No. 19-MAR-102R

BUDGETED CASH TRANSFERS

<u>TRANSFERS</u>	<u>CURRENT</u>	<u>ADJUSTMENT</u>	<u>ADJUSTED</u>	<u>PURPOSE</u>
401 General Fund	\$ (72,969,915.00)	\$ (20,000.00)	\$ (72,989,915.00)	Transfer for capital adjustment
463 Event Center	\$ 1,246,497.00	\$ 20,000.00	\$ 1,266,497.00	Transfer for capital adjustment

3rd Qtr. FY 19 SNCP SB268 Payment

FY18 Matched Taxable Gross Receipts	\$5,153,349,556.54
FY19 1/12 th Increment Due	\$ 4,294,457.96
FY19 Quarterly Amount Due	\$ 1,073,614.49

STATE OF NEW MEXICO
COUNTY OF LEA
RESOLUTION NO. 19-MAR-103R

A RESOLUTION AUTHORIZING LEA COUNTY'S FY 2018 – 2019 3RD QUARTER PAYMENT
AND CERTIFICATION FOR THE SAFETY NET CARE POOL (SNCP) FUND

WHEREAS, in January 2014 the Sole Community Provider Program was replaced by the Safety Net Care Pool (SNCP) through the adoption of Senate Bill 268; *and*

WHEREAS, SNCP payments are dispersed state wide for uncompensated care and hospital quality improvements; *and*

WHEREAS, Lea County's 3rd quarter contribution to the SNCP funds is due in the amount of \$1,073,614.49.

NOW, THEREFORE, BE IT HEREBY RESOLVED that the Board of County Commissioners of Lea County, that staff is hereby authorized and directed to issue the 3rd quarter payment in the amount of \$1,073,614.49 for the SNCP.

PASSED AND APPROVED on this 21st day of March, 2019, by the Lea County Board of County Commissioners in an open meeting in Lovington, New Mexico.

LEA COUNTY BOARD OF COUNTY COMMISSIONERS

Rebecca Long (District 2), Chair
Voted: Yes No Abstain

Dean Jackson (District 1), Vice Chair
Voted: Yes No Abstain

Gary G. Eidson (District 3), Member
Voted: Yes No Abstain

Jonathan Sena (District 4), Member
Voted: Yes No Abstain

Richard Don Jones (District 5), Member
Voted: Yes No Abstain

ATTEST: Keith Manes
Lea County Clerk

**APPROVED AS TO FORM AND LEGAL
SUFFICIENCY:**

By: _____
Kelli Williams, Deputy Clerk

John W. Caldwell, County Attorney

NEW MEXICO HUMAN SERVICES DEPARTMENT
SAFETY NET CARE POOL PAYMENT PROGRAM
CERTIFICATION FOR LOCAL GOVERNMENTAL ENTITY PARTICIPATION

3rd QUARTER OF SFY 2019

On behalf of the Lea County Board of Commissioners, a local government organized under the laws of the State of New Mexico (hereinafter referred to as the "Local Governmental Entity"), I, Rebecca Long, Chair of the Lea County Board of County Commissioners, affirm and certify the following:

I. Definitions

- A. The term "Local Governmental Entity" means any County or Counties that makes a transfer of funds to the State of New Mexico for the purpose of funding a payment to any hospital under the New Mexico Medicaid program.
- B. The term "Supplemental Payment" means any payment to a hospital pursuant to the Safety Net Care Pool ("SNCP") Payment provisions of the New Mexico Medicaid program.
- C. The term "State" means the State of New Mexico or any of its officers or agencies.

II. Public Adoption and Access

- A. The governing body of the Local Governmental Entity adopted the conditions described in this Certification by recorded vote taken in a public meeting held in compliance with the applicable state and federal laws.

III. Funding for the Supplemental Payments

- A. The Local Governmental Entity shall transfer Public Funds to the State of New Mexico for use as the non-federal share of the Safety-Net Care Pool supplemental Medicaid payments to one or more hospitals in accordance with the New Mexico Indigent Hospital and County Health Care Act, NMSA 1978, Sections 27-5-1 to 12.1, specifically NMSA 1978, Section 27-5-6.1.
- B. All transfers of Public Funds by the Local Governmental Entity to the State to support payments to hospitals under the SNCP must comply with:
 - (1) The applicable regulations that govern provider-related donations codified at section 1903 (s) of the Social Security Act (42 U.S.C. § 1396 b(w)), and Title 42, Code of Federal Regulations, Part 433, subpart B, section 433.52 and 433.54; and
 - (2) The conditions approved by the federal Centers for Medicare and Medicaid Services ("CMS") for governmental entities' and hospitals' participation in the SNCP.

IV. Assurances and Representations

- A. The Local Governmental Entity does not and will not at any time receive any part of the Supplemental Payments that are made to hospitals under the SNCP.
- B. The Local Governmental Entity has not entered and will not enter into any agreement with Hospital to condition either the amount of Public Funds transferred by the Local Governmental Entity to the State or the amount of Supplemental Payments a Hospital receives on the amount of indigent care the Hospital has provided or will provide.
- C. The Local Governmental Entity has not received and will not receive refunds of payments the Local Governmental Entity made or makes to a Hospital for any purpose as consideration of any Intergovernmental Transfer from the Local Governmental Entity to the State to support the Supplemental Payments.
- D. The Local Governmental Entity has not received at any time after September 30, 2011, and will not receive any cash or in-kind transfers from a Hospital or any other entity acting on behalf of a hospital group of affiliated hospitals other than transfers that:
 - (1) Are unrelated to the administration of the SNCP Payment Program or the delivery of indigent care services by the Hospital(s); and
 - (2) Constitute fair market value for goods or services provided by the Local Governmental Entity to a Hospital; or
 - (3) Represents independent, bona fide transactions or arrangements negotiated at arms-length and in the ordinary course of business between the Hospital and the Local Governmental Entity.
- E. Except as specified in D, above, the Local Governmental Entity has not since September 30, 2011:
 - (1) Assigned or agreed to assign a contractual or statutory obligation of the Local Governmental Entity to a Hospital or any other entity acting on behalf of a Hospital or group of affiliated hospitals; or
 - (2) Authorized or consented to the assumption of a statutory or contractual obligation of the Local Governmental Entity by a Hospital or any other entity acting on behalf of a hospital or group of affiliated hospitals.

V. Education

- A. Consistent with its constitutional, statutory, and fiduciary obligations, the Local Governmental Entity may evaluate a Hospital's historical experience in providing indigent care in the community, including the impact and amount of indigent care provided by the Hospital, for the following purposes:

- (1) To determine whether the Hospital's performance benefit the community and whether its continued participation in the indigent care program is likely to continue to benefit the community; and/or
- (2) To provide accountability to local taxpayers.

B. The Local Governmental Entity's evaluation under this provision may:

- (1) Occur on a schedule determined by the Local Governmental Entity, but not more often than once each calendar quarter;
- (2) Be documented in a manner sufficient to confirm achievement of the Local Governmental Entity's mission and provide an appropriate and constitutional basis on which a transfer of Public Funds has been made to the State; and
- (3) Not include consideration of matters expressly prohibited herein or prohibited by state and federal laws and regulations.

ON BEHALF of the Local governmental Entity, I hereby certify that I have read and understood the above statements; that the statements are true, correct, and complete; and that I am authorized to bind the Local Governmental Entity and to certify to the above.

March 21, 2019

SIGNATURE

DATE

Rebecca Long, Chair, Lea County Board of County Commissioners

PRINTED NAME AND TITLE





**LEA COUNTY BOARD OF COUNTY COMMISSIONERS
AGENDA ITEM SUMMARY FORM**

LCBCC Meeting Date: Thursday, March 21, 2019

Submit this summary form & all attachments to the Finance Director clow@leacounty.net & cc the Executive Coordinator sstout@leacounty.net by: **March 5, 2019**

County Manager Approval (mgallagher@leacounty.net) required for all time sensitive issues that do not meet the above deadline.

DATE SUBMITTED mm-dd-yyyy:	SUBMITTED BY Name/Title/Dept: Chip Low, Finance Director	
SUBJECT: Lea County's 2019 - 2020 FY Budget	ATTACHMENT(S):	
NO. OF ORIGINALS FOR SIGNATURE: 00 ***Select One** 00 ***Select One** 00 ***Select One**	ACTION REQUESTED: Discussion Item	
STRATEGIC PLAN Implementation of 5 Year Strategic Plan:		
SUMMARY:		
Requested Items Needed for Presentation Easels/Laptop/Projector/Etc.: Easel <input type="checkbox"/> Laptop <input checked="" type="checkbox"/> Projector <input checked="" type="checkbox"/> Other: _____ <small>If checked, how many:</small>	See Additional Summary Attached <input type="checkbox"/>	
SUBMITTER'S RECOMMENDATION(S): Discussion Only	Submitter's Signature Department Director, Etc.	
FINANCE REVIEW Fiscal Impact/Cost:	Reviewed by Finance Director	
LEGAL REVIEW: ByPass Legal Review (Note: Travel does not need legal review)	Reviewed by County Attorney ByPass Legal Review Digitally signed by ByPass Legal Review Date: 2019.03.19 17:36:45 -06'00'	
COUNTY MANAGER REVIEW:	Approved by County Manager to be Placed on Agenda Digitally signed by Michael P. Gallagher <i>Michael Gallagher</i> Date: 2019.03.19 14:00:45 -06'00'	

<small>Item 0301</small> RECORDING SECRETARY'S USE ONLY ~ COMMISSION ACTION TAKEN		
Approved: _____	Denied: _____	Other: <u>Discussion</u> _____
Resolution No. _____	Policy No. _____	Ordinance No. _____
Continued To: _____	Referred To: _____	Comments: _____

Lea County Financial Report

For the 8 month ending February 28, 2019

Revenue vs. Expenditure

For the eight months ending February, 2019

Fund Type	Revenues	Expenditures	Cash Increase (Decrease)
Unrestricted Funds	\$ 50,321,648	\$ 15,568,316	\$ 34,753,332
Special Revenue Funds	\$ 14,437,063	\$ 18,186,109	\$ (3,749,047)
Designated Funds	\$ 1,364,359	\$ 14,554,684	\$ (13,190,325)
Debt Service Fund	\$ 5,853,309	\$ 250,331	\$ 5,602,978
Enterprise Fund	\$ -	\$ -	\$ -
Trust Funds	\$ 5,576,082	\$ 4,305,490	\$ 1,270,592
Total	\$ 77,552,460	\$ 52,864,930	\$ 24,687,530

Oil & Gas Production Revenue

104% of Budget - \$28,948,051

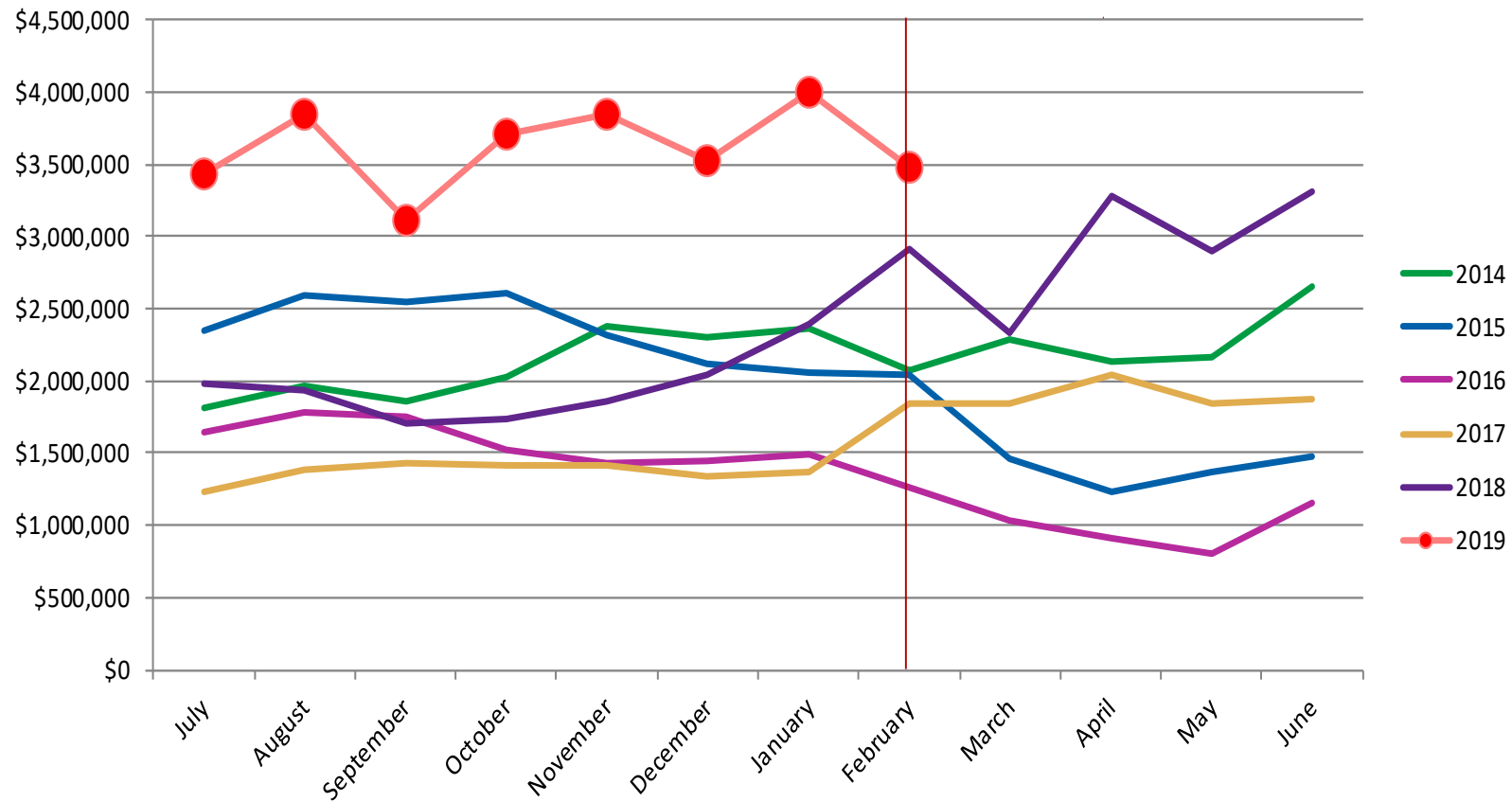

Property Tax Revenue

80.7% of Budget

Year to Date Comparison

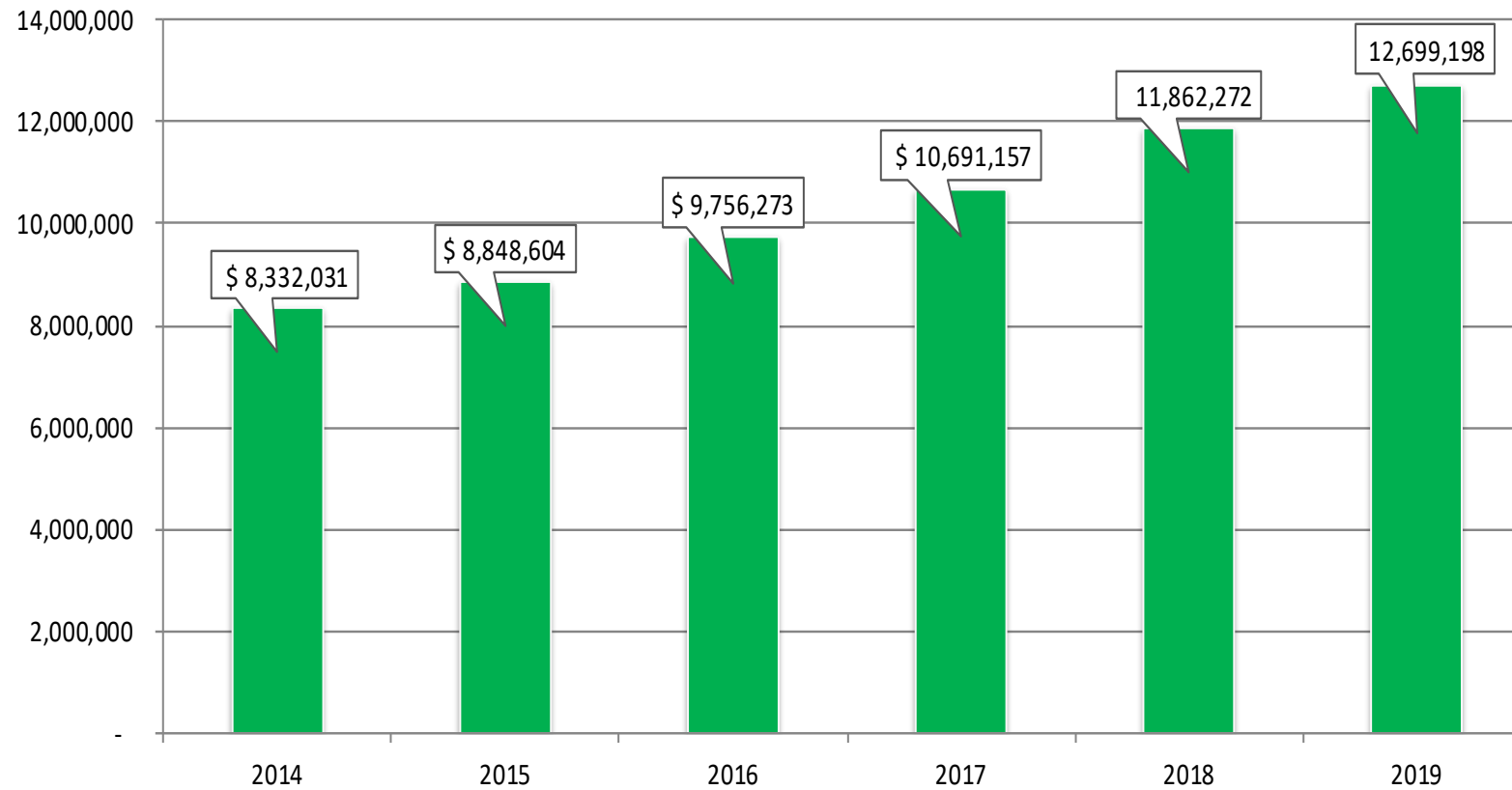

Gross Receipts Tax – All Sources

118.4% of Budget
 Indigent GRT \$5,849,988 Debt Service GRT \$5,849,988
 Environmental GRT \$2,993,231

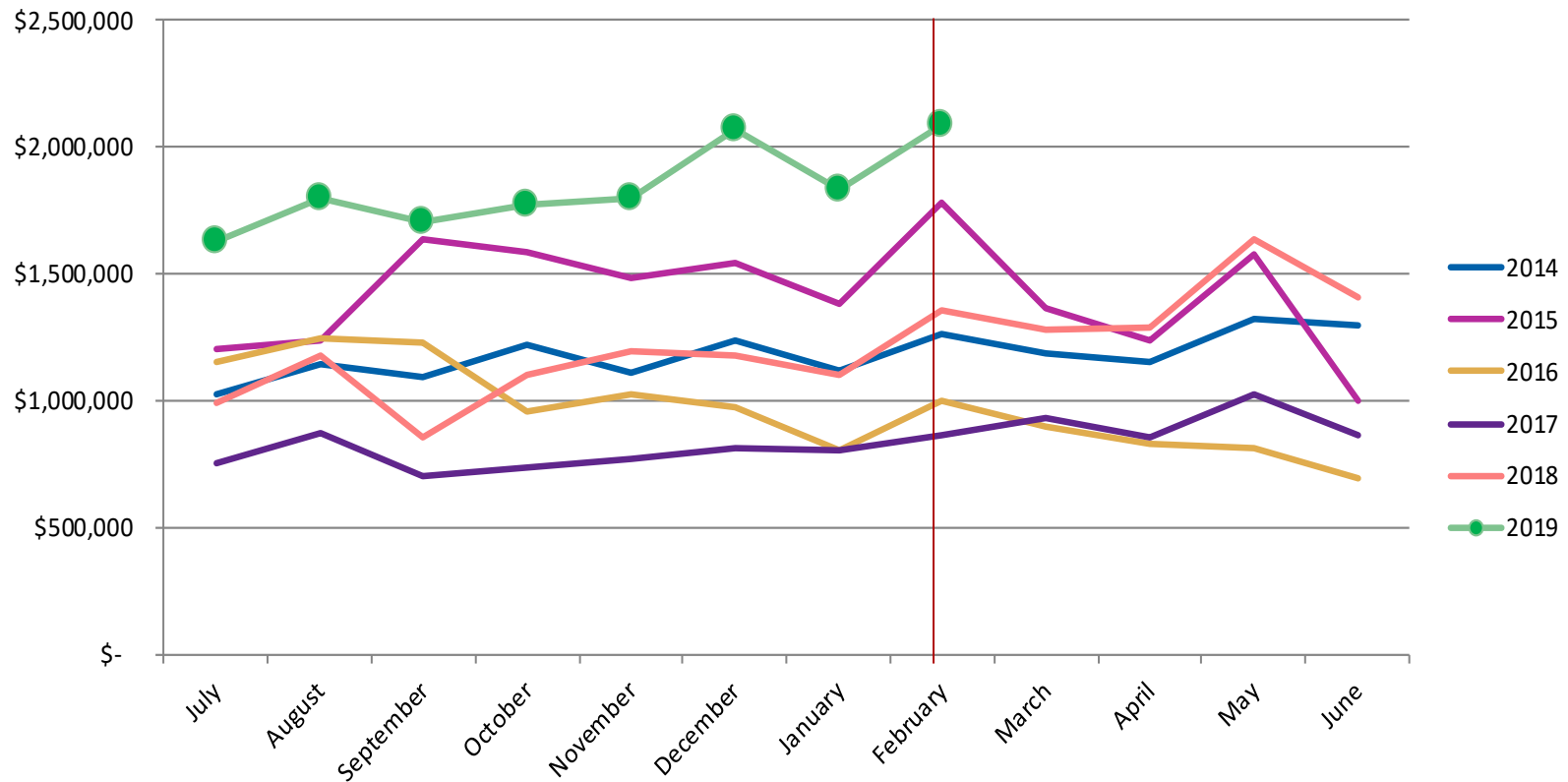

Expenditures – Year to Date – 33.0%

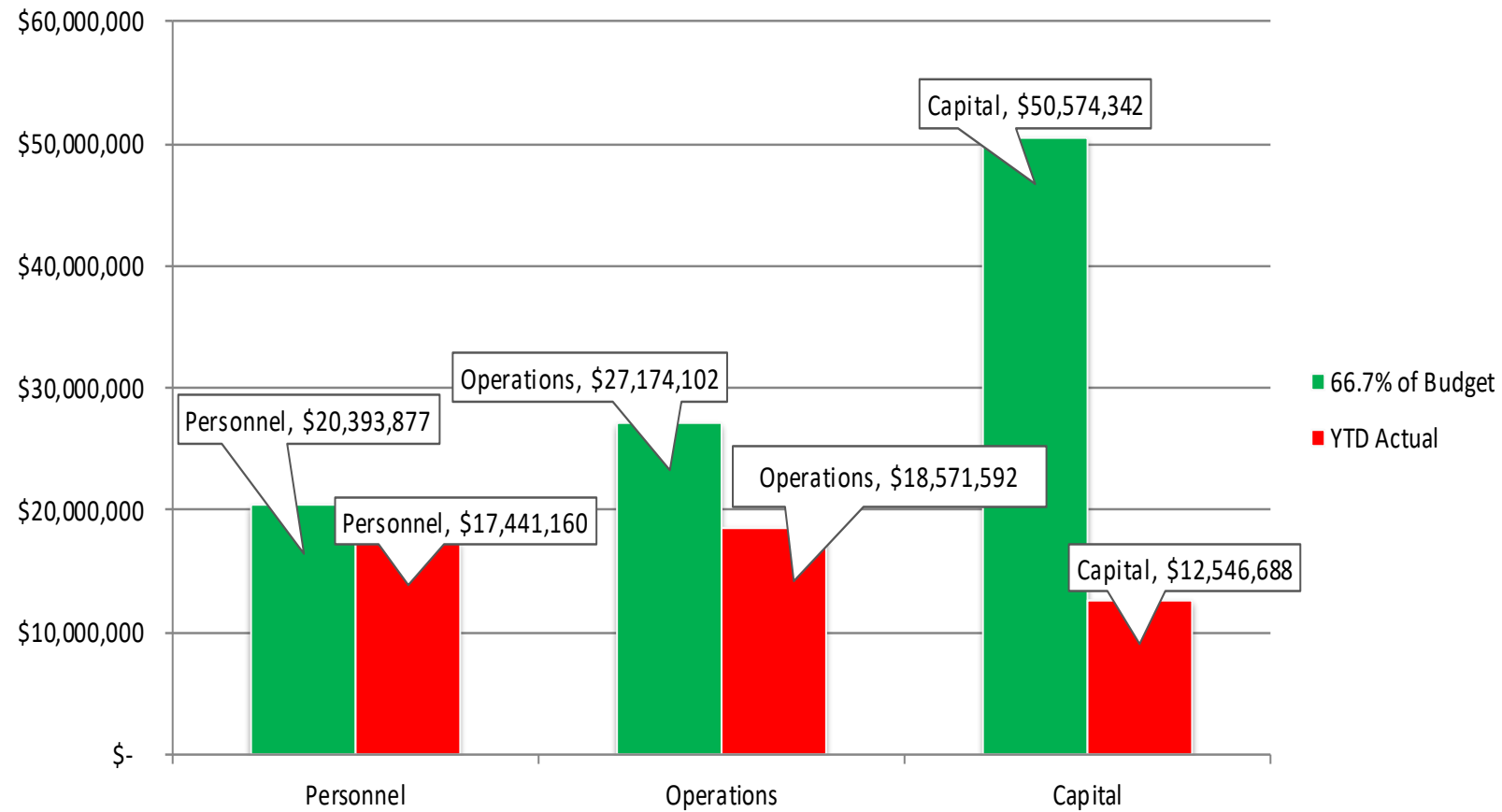



**LEA COUNTY BOARD OF COUNTY COMMISSIONERS
AGENDA ITEM SUMMARY FORM**

LCBCC Meeting Date: Thursday, March 21, 2019

Submit this summary form & all attachments to the Finance Director clow@leacounty.net & cc the Executive Coordinator sstout@leacounty.net by: **March 5, 2019**

County Manager Approval (mgallagher@leacounty.net) required for all time sensitive issues that do not meet the above deadline.

DATE SUBMITTED mm-dd-yyyy: 03/09/2019		SUBMITTED BY Name/Title/Dept: Chip Low - Finance Director	
SUBJECT: February 2019 Finance Report		ATTACHMENT(S): 1. February 2019 Finance Report	
NO. OF ORIGINALS FOR SIGNATURE: 00 ***Select One** 00 ***Select One** 00 ***Select One**		ACTION REQUESTED: Discussion Item	
STRATEGIC PLAN Implementation of 5 Year Strategic Plan: The information in the financial report meets the goals in Section 3.1 on Accountability which is "Lea County is responsible for the public's tax dollars in a fiscally conservative and transparent manner". Performance measures met include 3.1.1, 3.1.2 and 3.1.4.			
SUMMARY: Review and discussion of the February 2019 Finance Report.			
Requested Items Needed for Presentation Easels/Laptop/Projector/Etc.: Easel <input type="checkbox"/> If checked; how many: Laptop <input checked="" type="checkbox"/> Projector <input checked="" type="checkbox"/> Other: _____		See Additional Summary Attached <input type="checkbox"/>	
SUBMITTER'S RECOMMENDATION(S): Review and discussion of the February 2019 Finance Report		Submitter's Signature Department Director, Etc. Henry C Low Jr Digitally signed by Henry C Low Jr Date: 2019.03.09 10:17:43 -07'00'	
FINANCE REVIEW Fiscal Impact/Cost: There is no financial impact to Lea County with this agenda item.		Reviewed by Finance Director Henry C Low Jr Digitally signed by Henry C Low Jr Date: 2019.03.09 10:18:10 -07'00'	
LEGAL REVIEW: ByPass Legal Review (Note: Travel does not need legal review)		Reviewed by County Attorney ByPass Legal Review Digitally signed by ByPass Legal Review Date: 2019.03.20 13:17:28 -06'00'	
COUNTY MANAGER REVIEW:		Approved by County Manager to be Placed on Agenda Digitally signed by Michael P. Gallagher <i>Michael P. Gallagher</i> Date: 2019.03.20 13:17:42 -06'00'	
Item 0302 RECORDING SECRETARY'S USE ONLY ~ COMMISSION ACTION TAKEN			
Approved: _____	Denied: _____	Other: <u>Discussion</u> _____	
Resolution No. _____	Policy No. _____	Ordinance No. _____	
Continued To: _____	Referred To: _____	Comments: _____	



Finance Department

February 2019

Table of Contents

Section 1: Financial Reports

- **Income Statement**
- **Detailed Revenue & Expenditure Report**
- **Discretionary Cash Report**
- **Monthly Revenue & Expenditure Report**
- **Reconciliation of Discretionary Cash to Budgeted Transfers**

Section 2: Activity Reports

- **Accounts Payable**
- **Contract Administration**

Section 3: Vehicle Report

Lea County
Revenue vs Expenditures
For the month ending February 28, 2019

County Funds

<u>REVENUES</u>	<u>Budget</u>	<u>Actual</u>	<u>Pct Rec'd</u>	<u>Pct of Yr</u>
Oil and Gas Production & Equip	\$ 33,721,906	\$ 33,971,182	100.7%	66.7%
Property taxes & PILT	\$ 21,543,150	\$ 14,150,581	65.7%	66.7%
Gross receipts tax (all sources)	\$ 12,409,010	\$ 14,693,206	118.4%	66.7%
Grants (all sources)	\$ 11,932,693	\$ 2,791,039	23.4%	66.7%
Care of prisoners (all sources)	\$ 2,156,212	\$ 1,264,311	58.6%	66.7%
Other Revenue	\$ 5,425,995	\$ 5,106,060	94.1%	66.7%
Subtotal County Funds	\$ 87,188,966	\$ 71,976,378	82.6%	66.7%

<u>EXPENDITURES</u>	<u>Budget</u>	<u>Actual</u>	<u>Pct Exp'd</u>	<u>Pct of Yr</u>
Salaries, wages & benefits	\$ 30,575,527	\$ 17,441,160	57.0%	66.7%
Operations	\$ 40,740,783	\$ 18,571,592	45.6%	66.7%
Capital Outlay	\$ 75,823,601	\$ 12,546,688	16.5%	66.7%
Subtotal County Funds	\$ 147,139,911	\$ 48,559,440	33.0%	66.7%

YTD Revenues over Expenditures **\$ 23,416,938**

Trust & Agency Funds

<u>REVENUES/EXPENDITURES</u>	<u>Budget</u>	<u>Actual</u>	<u>Pct Rec'd</u>	<u>Pct of Yr</u>
All Sources	\$ 7,831,282	\$ 5,576,082	71.2%	66.7%
All Expenditures	\$ 7,172,652	\$ 4,305,490	60.0%	66.7%
YTD Revenues over Expenditures		\$ 1,270,592		

All Funds

<u>REVENUES/EXPENDITURES</u>	<u>Budget</u>	<u>Actual</u>	<u>Rec'd/Exp'd</u>	<u>Pct of Yr</u>
Total County Revenues	\$ 95,020,248	\$ 77,552,460	81.6%	66.7%
Total County Expenditures	\$ 154,312,563	\$ 52,864,930	34.3%	66.7%
YTD Revenues over Expenditures		\$ 24,687,530		

All Funds - Beginning Cash 07/01/18 **\$ 85,970,771**

General Fund - Beginning cash 07/01/2018	57,567,197
General Fund - Revenues over Expenditures	34,753,332
General Fund - Transfers In/(Out)	(16,442,581)
General Fund - Cash Balance as of 02/28/2019	75,877,947

Designated Funds - Beginning Cash 07/01/2018	18,085,389
Designated Funds - Revenues over Expenditures	(11,336,394)
Designated Funds - Transfers In/(Out)	16,442,581
Designated Funds - Cash Balance as of 02/28/2019	23,191,576

Trust and Agency Funds - Beginning Cash 07/01/2018	10,318,186
Trust and Agency Funds - Revenues over Expenditures	1,270,592
Trust and Agency - Transfers In/(Out)	-
Trust and Agency Funds - Cash Balance as of 02/28/2019	11,588,777

All Funds - Cash Balance as of 02/28/2019 **110,658,301**

(Unaudited - for management's use only)

LEA COUNTY, NEW MEXICO
Expenditure Report
Fiscal Year - As of February 28, 2019

FY 2017/2018 **FY 2018/2019**

Fund	Final Adjusted Budget	Year to Date Expended	Percentage of Budget Expended	Adjusted Budget	Year to Date Expended	Percentage of Budget Expended	CY vs PY \$ Change	CY vs PY % Change
	12 months	8 months	67% of Yr	12 months	8 months	67% of Yr	Δ	Δ
UNRESTRICTED FUNDS								
<i>(GENERAL, CAPITAL & DETENTION FUNDS)</i>								
Salaries and Benefits	20,640,169	12,737,159	62%	23,980,794	13,996,759	58%	1,259,600	10%
Operations:								
Community Agency Support	187,500	68,918	37%	235,000	79,592	34%	10,675	15%
Local Government Support	1,751,500	726,000	41%	2,587,000	546,594	21%	(179,406)	-25%
Economic Development	2,584,232	739,900	29%	2,163,000	739,745	34%	(154)	0%
LCCA	1,719,074	1,219,315	71%	1,834,361	1,122,543	61%	(96,772)	-8%
Other	10,867,309	5,531,618	51%	12,367,683	5,343,417	43%	(188,200)	-3%
Subtotal Operations	17,109,615	8,285,750	48%	19,187,044	7,831,892	41%	(453,858)	-5%
Capital Projects and Equipment	63,344,861	10,850,626	17%	47,458,474	8,294,350	17%	(2,556,276)	-24%
TOTAL UNRESTRICTED FUNDS	101,094,645	31,873,535	32%	90,626,312	30,123,000	33%	(1,750,534)	-5%
RESTRICTED FUNDS								
Special Revenue Funds								
Road	11,340,269	3,918,131	35%	13,474,431	4,456,503	33%	538,372	14%
Special Revenue - GRT	8,844,823	3,782,381	43%	12,326,681	5,737,265	47%	1,954,884	52%
Special Revenue - Other	14,674,647	4,707,094	32%	25,104,488	6,366,958	25%	1,659,863	35%
Grants	3,691,058	1,566,749	42%	4,584,083	1,625,384	35%	58,634	4%
Total Special Revenue Funds	38,550,797	13,974,355	36%	55,489,683	18,186,109	33%	4,211,754	30%
Debt Service	871,212	68,106	8%	875,482	250,331	29%	182,225	268%
Enterprise Fund	348,434	513	0%	148,434	-	0%	(513)	-100%
Funds Held In Trust	7,628,564	4,570,330	60%	7,172,652	4,305,490	60%	(264,840)	-6%
TOTAL RESTRICTED FUNDS	47,399,007	18,613,303	39%	63,686,251	22,741,930	36%	4,128,627	22%
TOTAL ALL FUNDS	148,493,652	50,486,838	34%	154,312,563	52,864,930	34%	2,378,093	5%

(Unaudited - for management's use only)

LEA COUNTY, NEW MEXICO
Revenue Report
Fiscal Year - As of February 28, 2019

FY 2017/2018 **FY 2018/2019**

Fund	FY 2017/2018			FY 2018/2019			Percentage of	CY vs PY \$ Change	CY vs PY % Change
	Final Budget	Year to Date Received	Percentage of Budget Collected	Budget	Year to Date Received	Budget Collected	Budget Collected		
	12 months	8 months	67% of Yr	12 months	8 months	67% of Yr		Δ	Δ
UNRESTRICTED FUNDS									
<i>(GENERAL, CAPITAL & DETENTION FUNDS)</i>									
Tax Revenue									
Oil and Gas Production	20,968,483	16,568,757	79%	27,779,095	28,948,051	104%		12,379,295	75%
Oil and Gas Equipment	3,299,826	3,220,719	98%	5,942,811	5,023,130	85%		1,802,412	56%
Property Tax- Current	15,744,576	11,473,149	73%	17,443,150	12,234,789	70%		761,640	7%
Property Tax - Delinquent	600,000	389,123	65%	500,000	464,409	93%		75,286	19%
Motor Vehicle Tax	250,000	169,620	68%	250,000	165,656	66%		(3,964)	-2%
PILT - Federal and Local	3,481,566	653,097	19%	3,600,000	1,451,383	40%		798,286	122%
Subtotal tax revenue	44,344,451	32,474,464	73%	55,515,056	48,287,419	87%		15,812,955	49%
Sales, Services, Activities Revenue									
Detention	2,269,935	1,417,339	62%	2,156,212	1,264,311	59%		(153,028)	-11%
Fairgrounds	-	-	N/A	-	-	N/A		-	N/A
Event Center	-	-	N/A	-	-	N/A		-	N/A
Subtotal Sales, Services, Activities	2,269,935	1,417,339	62%	2,156,212	1,264,311	59%		(153,028)	-11%
Grants									
Federal	17,000	-	0%	-	8,737	N/A		8,737	N/A
State	5,000	-	0%	100,000	100,000	100%		100,000	N/A
Other	3,000,000	-	0%	3,000,000	-	0%		-	N/A
Subtotal Grants	3,022,000	-	0%	3,100,000	108,737	4%		108,737	N/A
Other	1,353,855	1,716,000	127%	1,463,000	2,025,541	138%		309,541	18%
TOTAL UNRESTRICTED FUNDS	50,990,241	35,607,802	70%	62,234,268	51,686,007	83%		16,078,205	45%
Net Transfers	-	(4,706,025)		(24,669,255)	(2,942,581)	12%		1,763,444	-37%
After Transfers	50,990,241	30,901,777	61%	37,565,013	48,743,426	130%		17,841,649	58%
RESTRICTED FUNDS									
Special Revenue Funds									
Special Revenue - GRT	5,725,347	5,299,114	93%	7,489,010	8,843,218	118%		3,544,104	67%
Special Revenue - Other	3,320,319	2,561,277	77%	3,711,995	2,911,542	78%		350,266	14%
Grants	12,362,582	3,548,009	29%	8,832,693	2,682,302	30%		(865,708)	-24%
Total Special Revenue Funds	21,408,248	11,408,401	53%	20,033,698	14,437,063	72%		3,028,662	27%
Net Transfers	-	4,706,025	N/A	30,570,340	8,732,098	29%		4,026,073	86%
After Transfers	21,408,248	16,114,426	75%	50,604,038	23,169,161	46%		7,054,735	44%
Debt Service GRT									
Debt Service GRT	4,068,126	3,664,272	90%	4,921,000	5,853,309	119%		2,189,037	60%
Net Transfers	-	-	N/A	(5,901,085)	(5,789,517)	98%		(5,789,517)	N/A
After Transfers	4,068,126	3,664,272	90%	(980,085)	63,792	-7%		(3,600,480)	-98%
Enterprise Fund									
Enterprise Fund	-	-	N/A	-	-	N/A		-	N/A
Net Transfers	-	-	N/A	-	-	N/A		-	N/A
After Transfers	-	-	N/A	-	-	N/A		-	N/A
Funds Held in Trust									
Funds Held in Trust	7,425,020	4,976,677	67%	7,831,282	5,576,082	71%		599,404	12%
Net Transfers	-	-	N/A	-	-	N/A		-	N/A
After Transfers	7,425,020	4,976,677	67%	7,831,282	5,576,082	71%		599,404	12%
TOTAL RESTRICTED FUNDS	32,901,394	20,049,350	61%	32,785,980	25,866,453	79%		5,817,103	29%
Net Transfer	-	4,706,025	N/A	24,669,255	2,942,581	12%		(1,763,444)	-37%
After Transfers	32,901,394	24,755,375	75%	57,455,235	28,809,034	50%		4,053,659	16%
TOTAL ALL FUNDS	83,891,635	55,657,152	66%	95,020,248	77,552,460	82%		21,895,308	39%

(Unaudited - for management's use only)

Discretionary Cash

2/28/2019

	FY 14/15	FY 15/16	FY 16/17	FY 17/18	FY 18/19
Ending Cash	65,262,660	63,648,152	67,453,016	57,567,197	75,877,947
Operational Budget	33,261,446	31,914,377	31,537,719	27,868,182	32,572,880
3/12th Reserve	8,315,362	7,978,594	7,884,430	6,967,046	8,143,220
Discretionary Cash (3/12th)	56,947,298	55,669,558	59,568,587	50,600,151	67,734,727
5.2/12th Reserve	13,858,936	13,297,657	13,666,345	12,076,212	14,114,915
Discretionary Cash (5/12th)	51,403,724	50,350,495	53,786,671	45,490,985	61,763,033

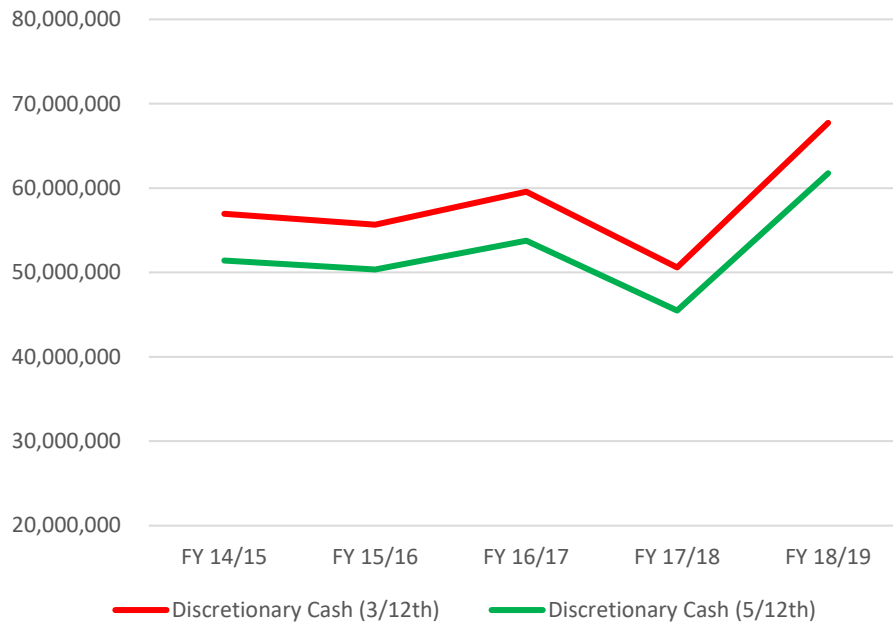

(Unaudited - for management's use only)

Lea County
General, Capital, Detention, Special Revenue, and Enterprise Fund Expenditures FY19

Historical Data

	Personnel	% Expn'd	Operations	% Expn'd	Capital	% Expn'd	Total	% Expn'd	% of Yr
Budget	\$ 30,575,527	100%	\$ 40,740,783	100%	\$ 75,823,601	100%	\$ 147,139,911	100%	100%
July	1,882,236	6.2%	2,841,071	7.0%	494,766	0.7%	5,218,073	3.5%	8.3%
August	2,107,079	6.9%	2,652,874	6.5%	774,071	1.0%	5,534,024	7.3%	16.7%
September	2,059,605	6.7%	2,826,935	6.9%	1,050,012	1.4%	5,936,552	11.3%	25.0%
October	2,029,540	6.6%	1,760,981	4.3%	2,402,399	3.2%	6,192,920	15.6%	33.7%
November	2,823,385	9.2%	1,428,314	3.5%	2,664,378	3.5%	6,916,076	20.3%	41.9%
December	2,195,913	7.2%	3,494,329	8.6%	2,261,295	3.0%	7,951,537	25.7%	50.0%
January	2,184,445	7.1%	1,971,798	4.8%	1,420,499	1.9%	5,576,741	29.4%	58.3%
February	2,158,957	7.1%	1,595,290	3.9%	1,479,269	2.0%	5,233,516	33.0%	66.7%
March	-	0.0%	-	0.0%	-	0.0%	-	-	-
April	-	0.0%	-	0.0%	-	0.0%	-	-	-
May	-	0.0%	-	0.0%	-	0.0%	-	-	-
June	-	0.0%	-	0.0%	-	0.0%	-	-	-
Total	17,441,160	57.0%	18,571,592	45.6%	12,546,688	16.5%	48,559,440	33.0%	66.7%
Remaining Budget	13,134,367	43.0%	22,169,191	54.4%	63,276,913	83.5%	98,580,471	67.0%	33.3%

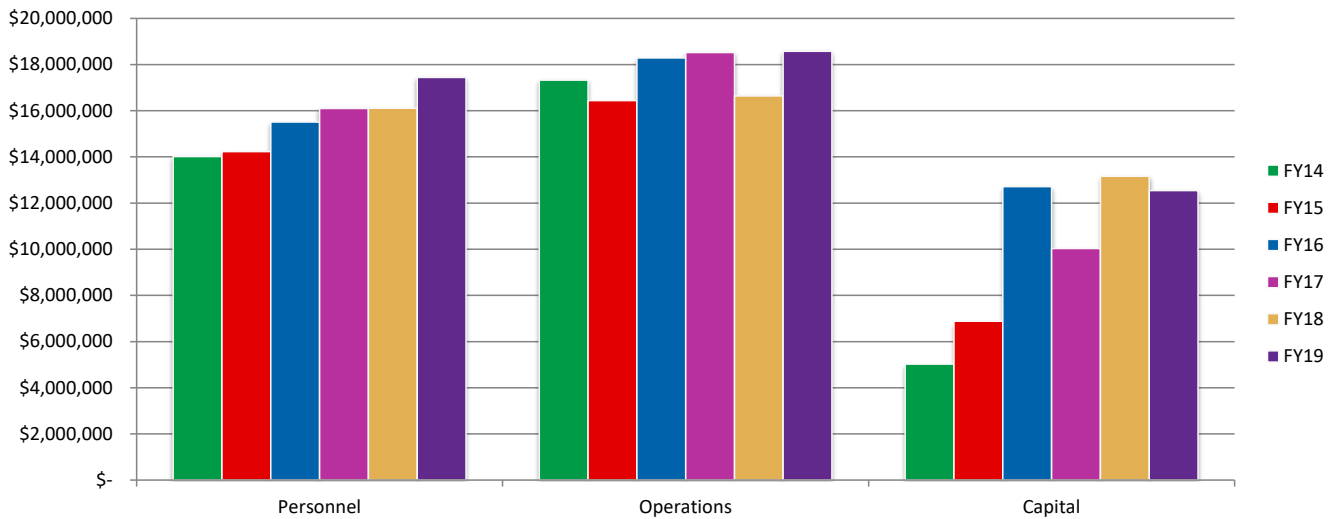
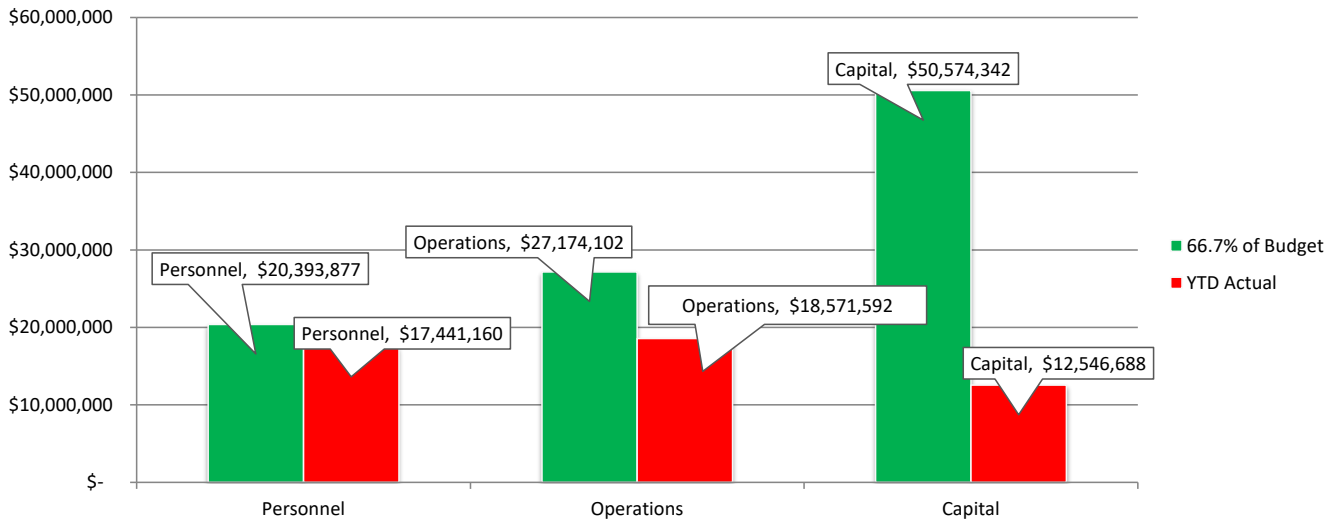

(Unaudited - for management's use only)

**Lea County
Oil and Gas Production Revenue
Historical Data**

	2014	2015	2016	2017	2018	2019	% Inc/Dec	% of Bdgt Collected	% of Yr
July	\$1,814,565	\$2,351,379	\$1,649,487	\$1,225,981	\$1,979,953	\$3,438,399	73.7%	12.4%	8.3%
August	1,960,128	2,595,230	1,785,885	1,384,390	1,940,661	3,848,188	98.3%	26.2%	16.7%
September	1,857,399	2,554,872	1,759,423	1,433,817	1,713,785	3,106,645	81.3%	37.4%	25.0%
October	2,022,683	2,612,414	1,527,798	1,418,544	1,732,992	3,713,028	114.3%	50.8%	33.3%
November	2,385,855	2,311,923	1,438,393	1,416,787	1,852,128	3,842,449	107.5%	64.6%	41.7%
December	2,308,201	2,124,366	1,439,692	1,335,927	2,047,167	3,520,439	72.0%	77.3%	50.0%
January	2,367,846	2,052,081	1,492,942	1,363,143	2,395,094	3,997,636	66.9%	91.7%	58.3%
February	2,068,306	2,035,304	1,260,020	1,839,019	2,906,976	3,481,268	19.8%	104.2%	66.7%
March	2,283,675	1,465,891	1,037,179	1,838,495	2,328,432		N/A	N/A	N/A
April	2,135,152	1,230,370	904,652	2,047,173	3,280,064		N/A	N/A	N/A
May	2,170,678	1,364,070	804,433	1,842,600	2,893,372		N/A	N/A	N/A
June	2,650,087	1,482,694	1,153,619	1,871,304	3,315,521		N/A	N/A	N/A
Total	\$26,024,577	\$24,180,592	\$16,253,522	\$19,017,180	\$28,386,145	\$28,948,051	74.7%	104.2%	66.7%

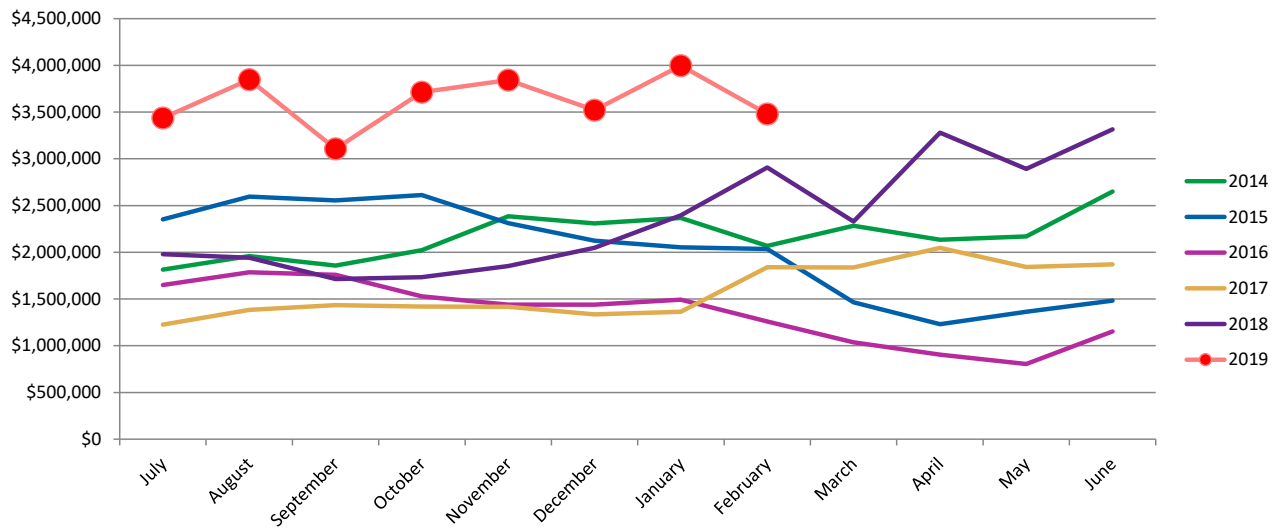

Year to Date Comparison

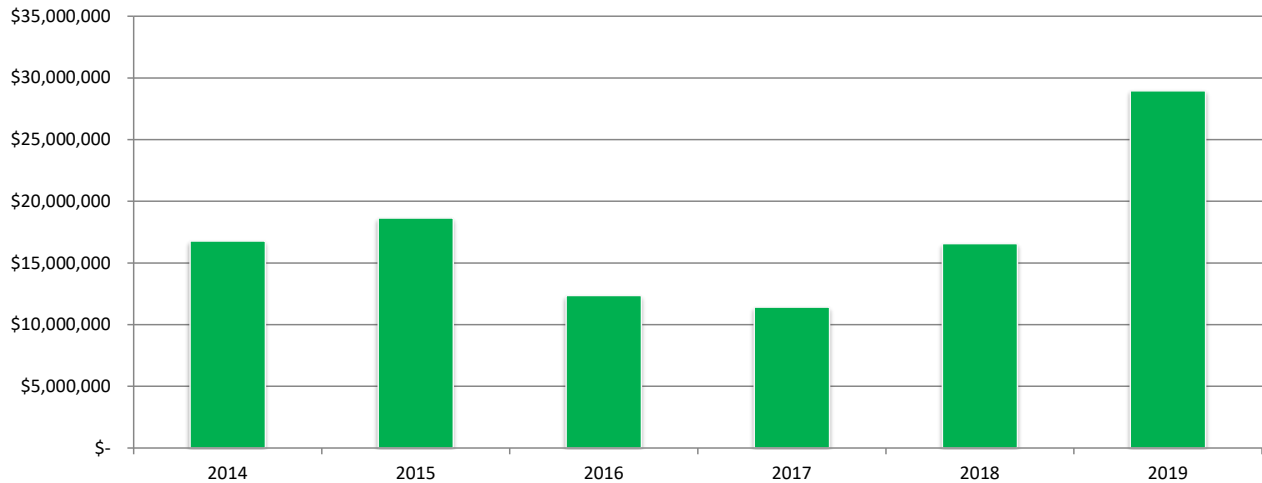

(Unaudited - for management's use only)

Lea County
Current and Delinquent Property Tax Revenue
Historical Data

							%		
	2014	2015	2016	2017	2018	2019	Inc/Dec From PY	% of Bdgt Collected	
July	\$ 59,222	\$ 74,335	\$ 11,987	\$ 427,035	\$ 101,431	\$ 64,340	-36.6%	0.4%	8.3%
	39,211	30,078	\$ 267,251	\$ 41,097	\$ 40,900	\$ 33,251	-18.7%	0.6%	16.7%
September	26,476	48,658	\$ 27,502	\$ 57,744	\$ 41,474	\$ 246,582	494.6%	2.2%	25.0%
October	205,010	21,898	\$ 1,190,284	\$ 218,382	\$ 20,639	\$ 1,431,326	6834.9%	11.3%	33.3%
November	4,254,229	4,634,917	\$ 4,472,198	\$ 3,830,294	\$ 5,227,938	\$ 4,424,706	-15.4%	39.4%	41.7%
December	3,315,369	3,663,874	\$ 3,212,368	\$ 5,564,969	\$ 5,530,394	\$ 6,220,260	12.5%	78.9%	50.0%
January	330,252	159,519	\$ 409,170	\$ 364,733	\$ 528,616	\$ 96,790	-81.7%	79.5%	58.3%
February	102,262	215,325	\$ 165,512	\$ 186,903	\$ 370,880	\$ 181,942	-50.9%	80.7%	66.7%
March	392,822	352,977	\$ 610,939	\$ 317,829	\$ 249,748		N/A	N/A	N/A
April	1,525,229	1,371,010	\$ 1,741,097	\$ 2,301,310	\$ 2,335,477		N/A	N/A	N/A
May	1,567,453	2,146,651	\$ 2,233,582	\$ 2,288,911	\$ 2,199,729		N/A	N/A	N/A
June	178,080	214,723	\$ 229,902	\$ 196,164	\$ 241,927		N/A	N/A	N/A
Total	\$ 11,995,615	\$ 12,933,964	\$ 14,571,794	\$ 15,795,371	\$ 16,889,154	\$ 12,699,198	7.1%	80.7%	66.7%

Year to Date Comparison

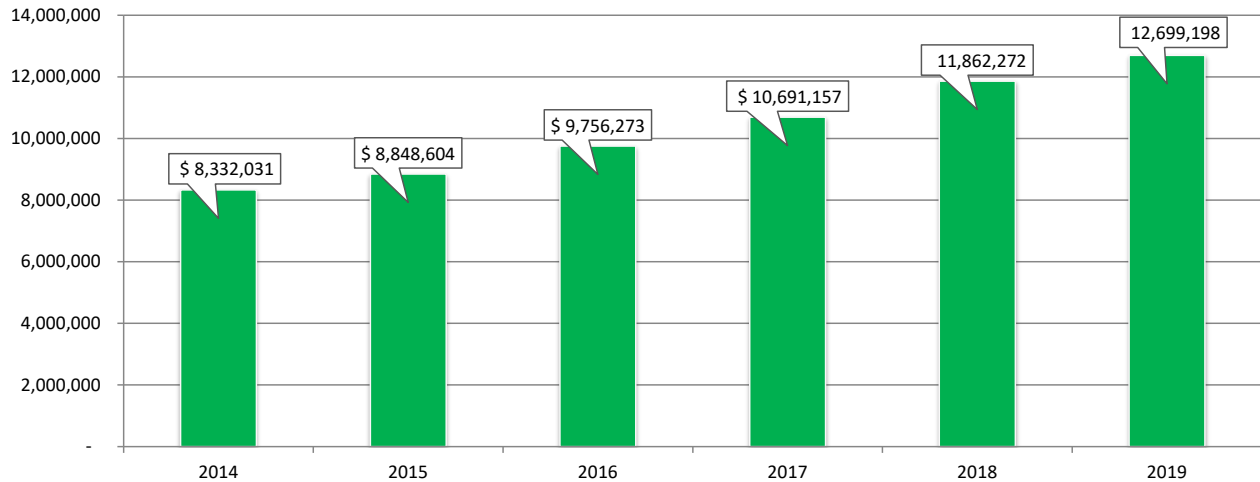

Property Valuations

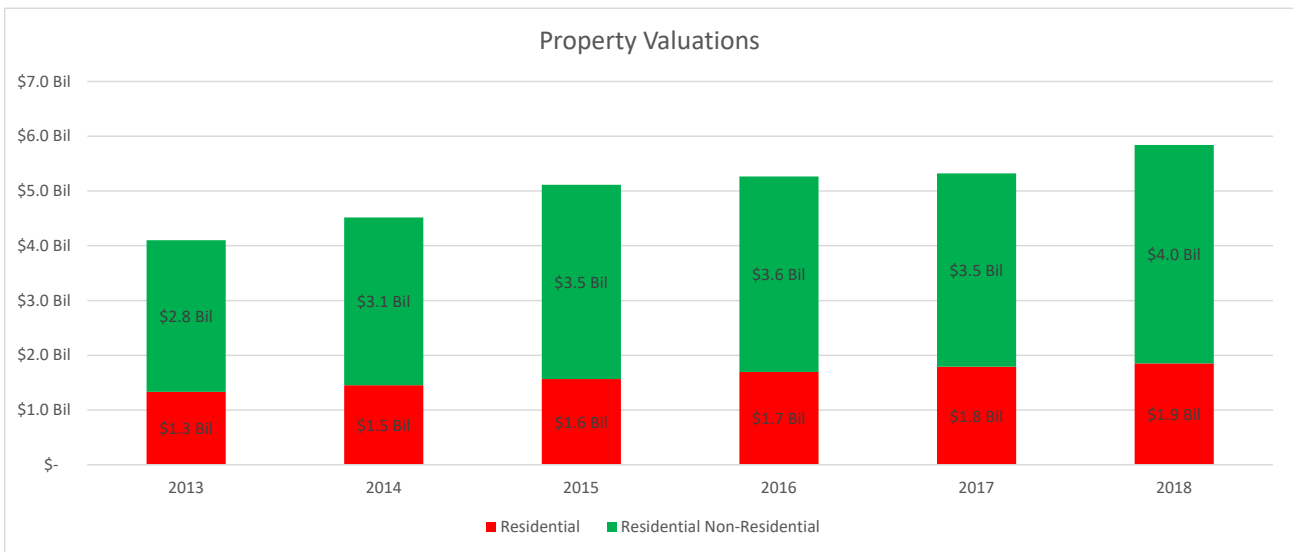

(Unaudited - for management's use only)

**Lea County
GRT Combined Revenue - All Levies
Historical Data**

							%		
	2014	2015	2016	2017	2018	2019	Inc/Dec From PY	% of Bdgt Collected	% of Yr
July	\$ 1,020,350	\$ 1,202,976	\$ 1,152,984	\$ 753,911	\$ 990,726	\$ 1,629,978	64.5%	13.1%	8.3%
August	1,139,277	1,240,642	1,246,139	868,366	1,177,793	\$ 1,798,282	52.7%	27.6%	16.7%
September	1,095,645	1,633,926	1,226,488	701,932	857,431	\$ 1,706,375	99.0%	41.4%	25.0%
October	1,217,456	1,583,248	958,779	737,111	1,103,598	\$ 1,770,490	60.4%	55.6%	33.3%
November	1,106,962	1,479,551	1,021,528	766,360	1,197,757	\$ 1,799,119	50.2%	70.1%	41.7%
December	1,238,827	1,544,698	974,360	814,291	1,180,361	\$ 2,070,127	75.4%	86.8%	50.0%
January	1,115,357	1,382,941	799,576	800,348	1,102,014	\$ 1,830,726	66.1%	101.6%	58.3%
February	1,261,689	1,779,512	998,031	864,312	1,351,752	\$ 2,088,110	54.5%	118.4%	66.7%
March	1,183,650	1,366,582	898,371	928,345	1,279,648		N/A	N/A	N/A
April	1,148,111	1,239,986	826,566	853,881	1,287,811		N/A	N/A	N/A
May	1,321,991	1,579,230	808,081	1,028,343	1,635,261		N/A	N/A	N/A
June	1,292,707	1,002,681	690,827	863,464	1,404,137		N/A	N/A	N/A
Total	14,142,022	17,035,973	11,601,730	9,980,663	14,568,289	14,693,206	64.0%	118.4%	66.7%

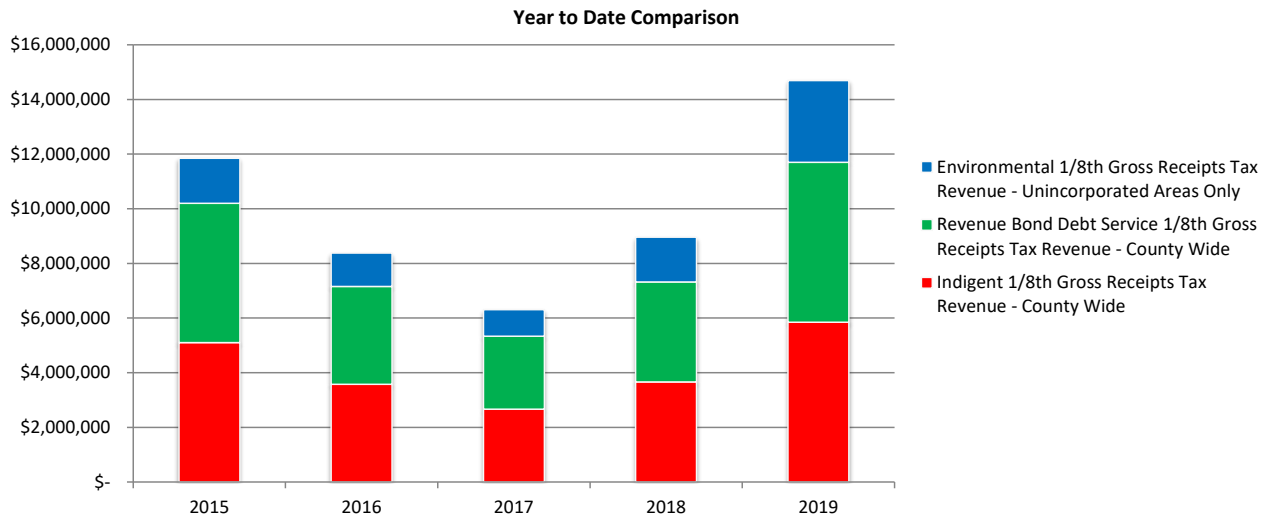
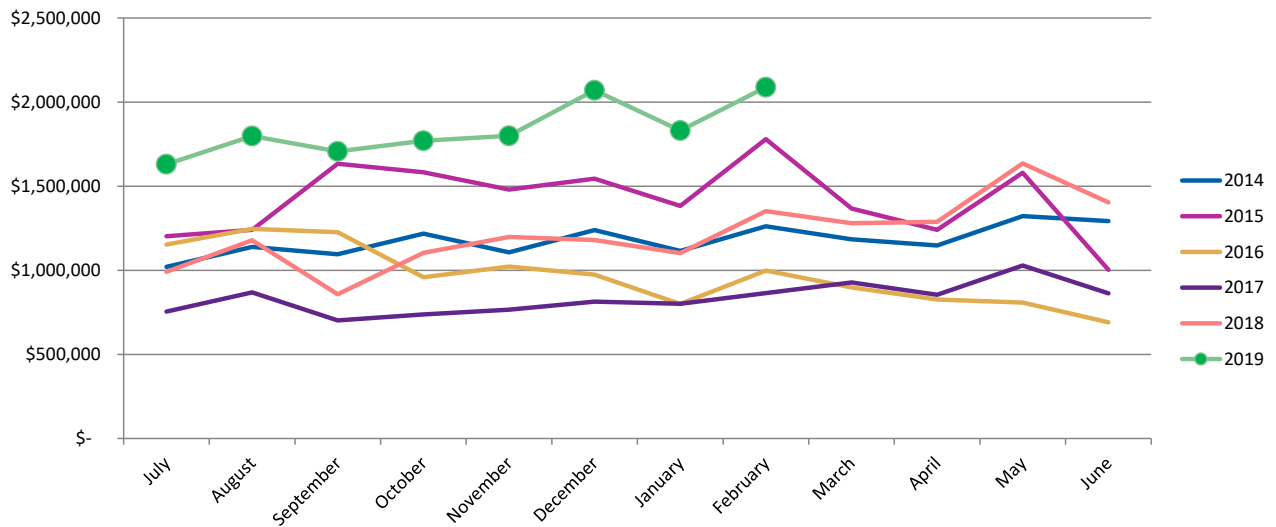

(Unaudited - for management's use only)

Lea County
Indigent 1/8th Gross Receipts Tax Revenue - County Wide
Historical Data

							%		
	2014	2015	2016	2017	2018	2019	Inc/Dec From PY	% of Bdgt Collected	
July	\$ 448,788	\$ 526,540	\$ 496,667	\$ 317,756	\$ 409,770	\$ 654,572	59.7%	12.3%	8.3%
August	503,508	545,812	532,945	373,126	480,527	\$ 725,078	50.9%	25.9%	16.7%
September	480,368	686,941	534,997	291,608	346,434	\$ 679,100	96.0%	38.6%	25.0%
October	533,985	670,560	397,081	309,027	452,070	\$ 703,865	55.7%	51.8%	33.3%
November	479,276	632,294	438,689	328,850	489,253	\$ 712,667	45.7%	65.2%	41.7%
December	536,760	672,577	413,722	342,532	476,940	\$ 817,486	71.4%	80.6%	50.0%
January	484,674	590,258	342,160	338,069	456,077	\$ 727,509	59.5%	94.2%	58.3%
February	544,204	773,902	419,748	367,369	551,247	\$ 829,711	50.5%	109.8%	66.7%
March	522,393	595,836	377,245	382,534	514,767		N/A	N/A	N/A
April	494,806	539,541	359,784	352,099	521,301		N/A	N/A	N/A
May	576,735	657,174	344,878	426,178	654,693		N/A	N/A	N/A
June	539,046	457,435	292,078	356,847	566,849		N/A	N/A	N/A
Total	\$ 6,144,543	\$ 7,348,870	\$ 4,949,995	\$ 4,185,993	\$ 5,919,928	\$ 5,849,988	59.7%	109.8%	66.7%

Lea County
Revenue Bond Debt Service 1/8th Gross Receipts Tax Revenue - County Wide
Historical Data

							%		
	2014	2015	2016	2017	2018	2019	Inc/Dec From PY	% of Bdgt Collected	
July	\$ 448,788	\$ 526,540	\$ 496,667	\$ 317,756	\$ 409,770	\$ 654,572	59.7%	13.3%	8.3%
August	503,508	545,812	532,945	373,126	480,527	\$ 725,078	50.9%	26.9%	16.7%
September	480,368	686,941	534,997	291,608	346,434	\$ 679,100	96.0%	39.7%	25.0%
October	533,985	670,560	397,081	309,027	452,070	\$ 703,865	55.7%	52.9%	33.3%
November	479,276	632,294	438,689	328,850	489,253	\$ 712,667	45.7%	66.2%	41.7%
December	536,760	672,577	413,722	342,532	476,940	\$ 817,486	71.4%	81.6%	50.0%
January	484,674	590,258	342,160	338,069	456,077	\$ 727,509	59.5%	95.2%	58.3%
February	544,204	773,902	419,748	367,369	551,247	\$ 829,711	50.5%	110.8%	66.7%
March	522,393	595,836	377,245	382,534	514,767		N/A	N/A	N/A
April	494,806	539,541	359,784	352,099	521,301		N/A	N/A	N/A
May	576,735	657,174	344,878	426,178	654,693		N/A	N/A	N/A
June	539,046	457,435	292,078	356,847	566,849		N/A	N/A	N/A
Total	\$ 6,144,543	\$ 7,348,870	\$ 4,949,995	\$ 4,185,993	\$ 5,919,928	\$ 5,849,988	-29.3%	110.8%	66.7%

Lea County
Environmental 1/8th Gross Receipts Tax Revenue - Unincorporated Areas Only
Historical Data

							%		
	2014	2015	2016	2017	2018	2019	Inc/Dec From PY	% of Bdgt Collected	
July	\$ 122,775	\$ 149,897	\$ 159,649	\$ 118,399	\$ 171,187	\$ 320,834	87.4%	14.9%	8.3%
August	132,261	149,017	180,250	122,113	216,738	\$ 348,125	60.6%	31.0%	16.7%
September	134,909	260,045	156,494	118,716	164,562	\$ 348,176	111.6%	47.1%	25.0%
October	149,486	242,127	164,617	119,057	199,457	\$ 362,761	81.9%	63.9%	33.3%
November	148,409	214,963	144,151	108,661	219,252	\$ 373,785	70.5%	81.2%	41.7%
December	165,307	199,544	146,915	129,226	226,481	\$ 435,155	92.1%	101.3%	50.0%
January	146,009	202,425	115,255	124,211	189,861	\$ 375,707	97.9%	118.7%	58.3%
February	173,280	231,708	158,535	129,574	249,259	\$ 428,687	72.0%	138.6%	66.7%
March	138,865	174,909	143,881	163,277	250,114		N/A	N/A	N/A
April	158,498	160,903	106,998	149,683	245,209		N/A	N/A	N/A
May	168,520	264,882	118,324	175,988	325,875		N/A	N/A	N/A
June	214,616	87,810	106,671	149,771	270,440		N/A	N/A	N/A
Total	\$ 1,852,936	\$ 2,338,233	\$ 1,701,739	\$ 1,608,677	\$ 2,728,433	\$ 2,993,231	82.9%	138.6%	66.7%

(Unaudited - for management's use only)

Fund Type	Revenues	Expenditures	Cash Increase (Decrease)
Unrestricted Funds	\$ 50,321,648	\$ 15,568,316	\$ 34,753,332
Special Revenue Funds	\$ 14,437,063	\$ 18,186,109	\$ (3,749,047)
Designated Funds	\$ 1,364,359	\$ 14,554,684	\$ (13,190,325)
Debt Service Fund	\$ 5,853,309	\$ 250,331	\$ 5,602,978
Enterprise Fund	\$ -	\$ -	\$ -
Trust Funds	\$ 5,576,082	\$ 4,305,490	\$ 1,270,592
Total	\$ 77,552,460	\$ 52,864,930	\$ 24,687,530

LEA COUNTY NEW MEXICO
Recap of Discretionary Cash and Commitments
As of February 28, 2019

General Fund Cash Balance -February 28, 2019	\$ 75,877,947
Less: 3/12ths reserve of General Fund Budget	<u>\$ (8,143,220)</u>
General Fund Cash Available for Commitments	\$ 67,734,727
Budgeted Cash Transfers In:	
Net of YTD Actual Or Projected Transfers	
Debt Service Fund	<u>\$ 111,568</u>
Total Discretionary Cash Available	<u>\$ 67,846,295</u>
Budgeted Cash Transfers Out:	
Net of YTD Actual Transfers	
Road Fund	\$ (7,756,902)
Farm & Range	\$ (72,000)
Community Centers	\$ (200,000)
Indigent Hospital Claims	\$ (1,650,000)
Airport Fire Depart	\$ (130,000)
Paving Districts	\$ (100,000)
Detention Facility	\$ (4,970,660)
Capital Projects	\$ (29,830,000)
Other Grants	\$ -
Lea Regional Airport	\$ (4,500,000)
Lovington Airport	\$ (47,604)
Jal Airport	\$ (85,239)
Lea County Fairgrounds	\$ (5,300,000)
Lea County Fair & Rodeo	\$ (300,000)
Lea County Event Center	\$ (646,497)
Hispanic Heritage Night	\$ -
Lea County Drug Task Force	\$ (50,000)
Lea County Fire Marshal	<u>\$ (1,000,000)</u>
Total Cash Transfers (Net YTD)	<u>\$ (56,638,902)</u>
Discretionary Cash Available - February 28, 2019	\$ 11,207,393
Budgeted Revenue over Expenses (Remainder of Year)	\$ (10,348,155)
Projected Excess/(Shortfall) in Budgeted Revenue (Remainder of Year)	<u>\$ -</u>
Total Discretionary Cash Available (Remainder of Year)	<u><u>\$ 859,239</u></u>

Accounts Payable

February 2019 and YTD

	February 2019	YTD
Number of Checks	432	4,048
Dollar Amount	\$ 2,892,656	\$ 32,995,238

Payroll

February 2019 and YTD

	February 2019	YTD
Number of Checks	674	5,658
Dollar Amount	\$ 1,052,318	\$ 8,795,141

Contract Administration

FY 18-19

The Finance Department is tracking 185 active contracts
as of February 2019

VEHICLE ACTIVITY REPORT FROM 2/1/2018 TO 3/1/2019

Description	License Plate	Beginning Odometer	Ending Odometer	Miles Traveled	Avg Miles Per Month	Gallons Used	MPG	Cost of Gasoline	Maint. Costs	W.O.s Pending
AIRPORT										
2007 Chevrolet 1500	G68108	102,187	113,402	11,215	892	702	16	\$1,798	\$0	2
2010 Ford F150 Ext Cab	G79019	175,969	187,003	11,034	864	789	14	\$1,980	\$0	2
2010 Ford F150 Ext Cab	G79020	137,736	141,741	4,005	479	263	15	\$719	\$0	3
2004 Chevrolet Silverado	G58823	0	0	0	0	0	0	\$0	\$0	2
2017 DODGE RAM 2500	G99531	0	0	0	0	0	0	\$0	\$0	0
DEPARTMENT TOTAL		415,892	442,146	26,254	2,235	1,754	9	\$4,496	\$0	9
ASSESSOR										
2008 Chevrolet Suburban	G73629	50,907	56,960	6,053	483	195	31	\$479	\$147	1
2014 Dodge Ram	G91467	65,021	76,011	10,990	845	624	18	\$1,638	\$160	1
2016 CHEVY PICKUP	G97076	12,472	18,931	6,459	514	264	24	\$644	\$50	2
DEPARTMENT TOTAL		128,400	151,902	23,502	1,842	1,083	24	\$2,762	\$357	4
CLERK										
2002 Dodge Durango	G50583	0	0	0	0	0	0	\$0	\$0	1
2012 Dodge Durango	G87417	44,507	53,334	8,827	728	405	22	\$1,003	\$0	2
DEPARTMENT TOTAL		44,507	53,334	8,827	728	405	11	\$1,003	\$0	3

VEHICLE ACTIVITY REPORT FROM 2/1/2018 TO 3/1/2019

Description	License Plate	Beginning Odometer	Ending Odometer	Miles Traveled	Avg Miles Per Month	Gallons Used	MPG	Cost of Gasoline	Maint. Costs	W.O.s Pending
DETENTION										
2002 Dodge Ram	G63349	0	0	0	0	0	0	\$0	\$0	1
2004 Chevrolet Silverado	G56734	159,543	159,543	0	0	0	0	\$0	\$0	0
2002 Dodge 2500 Ext Cab	G50131	129,754	130,682	928	84	131	7	\$357	\$167	0
2008 Ford Expedition	G73154	0	0	0	0	0	0	\$0	\$0	0
2006 Chevrolet Trail Blazer	G67322	95,049	102,537	7,488	698	345	22	\$882	\$1,150	2
2001 Dodge Intrepid	G79793	0	0	0	0	0	0	\$0	\$0	1
2010 Ford Explorer	G81943	48,533	58,147	9,614	755	410	23	\$1,050	\$2,438	1
2012 Ford Econoline 15 Pass.	G85537	159,704	192,086	32,382	2,563	1,735	19	\$4,264	\$4,314	1
2013 Ford 138 E-Series 15 Pass.	G88010	227,002	282,557	55,555	4,363	2,711	21	\$6,402	\$2,482	2
2013 FORD VAN	G88012	27,627	38,589	10,962	911	666	16	\$1,662	\$2,274	0
2016 Chevy Express Van	G96496	0	0	0	0	0	0	\$0	\$0	0
2018 CHEVROLET EXPRESS VAN	05320G	0	0	0	0	0	0	\$0	\$0	0
2018 CHEVROLET SILVERADO	03368G	0	0	0	0	0	0	\$0	\$69	0
DEPARTMENT TOTAL		847,212	964,141	116,929	9,374	5,997	8	\$14,618	\$12,894	8

VEHICLE ACTIVITY REPORT FROM 2/1/2018 TO 3/1/2019

Description	License Plate	Beginning Odometer	Ending Odometer	Miles Traveled	Avg Miles Per Month	Gallons Used	MPG	Cost of Gasoline	Maint. Costs	W.O.s Pending
DWI										
2007 Chevrolet Tahoe	G69712	146,011	152,333	6,322	1,581	297	21	\$758	\$170	2
2009 FORD VAN	G76011	203,042	205,956	2,914	236	171	17	\$434	\$384	1
2008 Dodge CLB	G93847	89,309	93,137	3,828	298	107	36	\$278	\$19	1
2016 FORD F-150	G96770	24,366	34,502	10,136	857	485	21	\$1,198	\$82	2
DEPARTMENT TOTAL		462,728	485,928	23,200	2,972	1,060	24	\$2,668	\$655	6
EMERGENCY MANAGEMENT										
2017 RAM CREW CAB PICKUP	G98750	0	0	0	0	0	0	\$0	\$0	0
2018 GMC	02578G	0	0	0	0	0	0	\$0	\$0	0
DEPARTMENT TOTAL		0	0	0	0	0	0	\$0	\$0	0

VEHICLE ACTIVITY REPORT FROM 2/1/2018 TO 3/1/2019

Description	License Plate	Beginning Odometer	Ending Odometer	Miles Traveled	Avg Miles Per Month	Gallons Used	MPG	Cost of Gasoline	Maint. Costs	W.O.s Pending
ENVIRONMENTAL SERVICES										
2006 Silverado Ext Cab	G63310	0	0	0	0	0	0	\$0	\$0	1
2007 Chevrolet 2500 Ext Cab	G70783	0	0	0	0	0	0	\$0	\$0	3
2005 Ford 139 Supercrew	G62094	158,018	159,161	1,143	164	74	15	\$193	\$0	3
2011 Ford F250 Ext Cab	G82405	190,607	209,137	18,530	1,640	1,132	16	\$3,107	\$0	3
2012 Ford F250 Ext Cab	G83826	119,429	135,391	15,962	1,247	1,270	13	\$3,037	\$0	3
2012 Chevrolet Silverado	G85363	0	0	0	0	0	0	\$0	\$0	3
2014 Dodge Ram	G89912	107,386	124,952	17,566	1,365	968	18	\$2,442	\$0	3
2014 Dodge Ram	G89913	71,127	92,523	21,396	1,803	1,052	20	\$2,841	\$0	2
2017 RAM CREW CAB PICKUP	G98751	0	0	0	0	0	0	\$0	\$0	0
2018 Dodge Ram 2500	02503G	0	0	0	0	0	0	\$0	\$0	0
2017 DODGE RAM 1500	01909G	0	0	0	0	0	0	\$0	\$0	0
2018 DODGE RAM	04828G	0	0	0	0	0	0	\$0	\$0	0
DEPARTMENT TOTAL		646,567	721,164	74,597	6,219	4,495	7	\$11,619	\$0	21

VEHICLE ACTIVITY REPORT FROM 2/1/2018 TO 3/1/2019

Description	License Plate	Beginning Odometer	Ending Odometer	Miles Traveled	Avg Miles Per Month	Gallons Used	MPG	Cost of Gasoline	Maint. Costs	W.O.s Pending
FAIR/RODEO										
1999 Chevrolet 1500	G39807	1	152,136	152,135	21,032	93	1,631	\$250	\$0	3
2007 Cehvrolet 2500 Ext Cab	G68974	8,374	172,787	164,413	15,609	407	404	\$1,054	\$0	3
2018 DODGE RAM	05265G	0	0	0	0	0	0	\$0	\$0	0
2011 Chevrolet Silverado	G83950	82,381	94,929	12,548	991	776	16	\$2,066	\$0	2
1986 FORD MHV	G36830	0	0	0	0	0	0	\$0	\$0	0
DEPARTMENT TOTAL		90,756	419,852	329,096	37,632	1,276	410	\$3,369	\$0	8
FINANCE										
2011 Chevrolet Tahoe	G82846	106,404	121,051	14,647	1,153	652	22	\$1,635	\$0	3
DEPARTMENT TOTAL		106,404	121,051	14,647	1,153	652	22	\$1,635	\$0	3
HR										
2008 Ford Expedition	G73153	167,461	181,493	14,032	1,096	741	19	\$1,906	\$0	2
DEPARTMENT TOTAL		167,461	181,493	14,032	1,096	741	19	\$1,906	\$0	2
IT										
2009 Chevrolet Impala	G77532	103,368	113,476	10,108	798	272	37	\$688	\$0	3
DEPARTMENT TOTAL		103,368	113,476	10,108	798	272	37	\$688	\$0	3

VEHICLE ACTIVITY REPORT FROM 2/1/2018 TO 3/1/2019

Description	License Plate	Beginning Odometer	Ending Odometer	Miles Traveled	Avg Miles Per Month	Gallons Used	MPG	Cost of Gasoline	Maint. Costs	W.O.s Pending
LCCA										
2012 Dodge Journey	G86923	59,194	68,818	9,624	740	474	20	\$1,218	\$0	1
2018 Chevrolet Tahoe	04324G	0	0	0	0	0	0	\$0	\$0	0
DEPARTMENT TOTAL		59,194	68,818	9,624	740	474	10	\$1,218	\$0	1
LEGAL										
2013 Chevrolet Impala	G86873	61,673	70,821	9,148	722	272	34	\$659	\$0	2
DEPARTMENT TOTAL		61,673	70,821	9,148	722	272	34	\$659	\$0	2

VEHICLE ACTIVITY REPORT FROM 2/1/2018 TO 3/1/2019

Description	License Plate	Beginning Odometer	Ending Odometer	Miles Traveled	Avg Miles Per Month	Gallons Used	MPG	Cost of Gasoline	Maint. Costs	W.O.s Pending
MAINTENANCE										
2002 Ford Styleside	G52169(NM)	2,639	2,639	0	0	244	0	\$614	\$0	0
2001 Dodge Intrepid	G46966	0	0	0	0	0	0	\$0	\$0	1
2002 Ford F150 4x2	G51643(NM)	0	0	0	0	0	0	\$0	\$0	0
2005 Chevrolet 1500	G60243(NM)	0	0	0	0	0	0	\$0	\$0	1
2007 Chevrolet 1500	G67388(NM)	185,640	189,992	4,352	346	246	18	\$649	\$0	3
2007 Chevrolet Silverado 1500	G70785(NM)	130,913	136,402	5,489	438	284	19	\$736	\$0	3
2006 Dodge 1500 Ext Cab	G65171	211,803	214,130	2,327	297	177	13	\$503	\$0	2
2008 Buick Lucerne	G72502	104,200	108,098	3,898	302	130	30	\$283	\$0	3
2007 Dodge Ram	G68016(NM)	185,049	188,946	3,897	328	249	16	\$626	\$0	3
2002 Ford Excursion	G52596	0	0	0	0	0	0	\$0	\$0	2
2014 Dodge Ram 1500 Ext Cab	G89764	54,159	67,488	13,329	1,099	711	19	\$1,922	\$0	2
2015 CHEVY PICKUP CC2	G95856	37,496	59,947	22,451	1,777	1,454	15	\$3,760	\$0	2
2017 GMC SIERRA 2WD	00619G	10,954	30,959	20,005	1,559	772	26	\$1,942	\$0	2
1994 Chevrolet Fleet Side	G36833	0	0	0	0	0	0	\$0	\$0	0
DEPARTMENT TOTAL		922,853	998,601	75,748	6,146	4,267	11	\$11,034	\$0	24

VEHICLE ACTIVITY REPORT FROM 2/1/2018 TO 3/1/2019

Description	License Plate	Beginning Odometer	Ending Odometer	Miles Traveled	Avg Miles Per Month	Gallons Used	MPG	Cost of Gasoline	Maint. Costs	W.O.s Pending
MALJAMAR FD										
2012 Chevrolet Silverado	G85364	4,162	14,211	10,049	791	233	43	\$589	\$0	0
DEPARTMENT TOTAL		4,162	14,211	10,049	791	233	43	\$589	\$0	0
MANAGER										
2011 Ford Expedition	G83806	70,611	74,919	4,308	1,034	181	24	\$465	\$0	2
DEPARTMENT TOTAL		70,611	74,919	4,308	1,034	181	24	\$465	\$0	2
SHERIFF										
2019 CHEVROLET TAHOE	04351G	0	0	0	0	0	0	\$0	\$0	0
2019 CHEVROLET TAHOE	04700G	0	0	0	0	0	0	\$0	\$0	0
DEPARTMENT TOTAL		0	0	0	0	0	0	\$0	\$0	0
Unassigned										
		0	0	0	0	0	0	\$0	\$0	0
2006 Ford E35	G90459	122,844	123,968	1,124	92	114	10	\$285	\$0	3
2006 Ford E35	G90460(NM)	528,274	153,512	-374,762	-35,355	43	-8,808	\$96	\$0	3
2011 GMC PICKUP	G98774	0	0	0	0	0	0	\$0	\$0	0
DEPARTMENT TOTAL		651,118	277,480	-373,638	-35,263	156	-2,199	\$381	\$0	6

Review of February 2019 Accounts Payable / Purchase Card Register

Checks # 1084468 - 1085008	\$2,892,656.28
P-Cards # 19671 - 19772	\$60,189.09
Total	\$2,952,845.37



**LEA COUNTY BOARD OF COUNTY COMMISSIONERS
AGENDA ITEM SUMMARY FORM**

LCBCC Meeting Date: Thursday, March 21, 2019

Submit this summary form & all attachments to the Finance Director clow@leacounty.net & cc the Executive Coordinator sstout@leacounty.net by: **March 5, 2019**

County Manager Approval (mgallagher@leacounty.net) required for all time sensitive issues that do not meet the above deadline.

DATE SUBMITTED mm-dd-yyyy: 03/09/2019		SUBMITTED BY Name/Title/Dept: Chip Low - Finance Director							
SUBJECT: February 2019 Accounts / Purchase Card Register		ATTACHMENT(S): 1. February 2019 AP/PC Register							
NO. OF ORIGINALS FOR SIGNATURE: 00 ***Select One** 00 ***Select One** 00 ***Select One**		ACTION REQUESTED: Discussion Item							
STRATEGIC PLAN Implementation of 5 Year Strategic Plan: The information in the financial report meets the goals in Section 3.1 on Accountability which is "Lea County is responsible for the public's tax dollars in a fiscally conservative and transparent manner". Performance measures met include 3.1.4.									
SUMMARY: <table border="0" style="width:100%"> <tr> <td>Checks # 1084468 - 1085008</td> <td align="right">\$2,892,656.28</td> </tr> <tr> <td>P-Cards # 19671 - 19772</td> <td align="right">\$60,189.09</td> </tr> <tr> <td>Total</td> <td align="right">\$2,952,845.37</td> </tr> </table>				Checks # 1084468 - 1085008	\$2,892,656.28	P-Cards # 19671 - 19772	\$60,189.09	Total	\$2,952,845.37
Checks # 1084468 - 1085008	\$2,892,656.28								
P-Cards # 19671 - 19772	\$60,189.09								
Total	\$2,952,845.37								
Requested Items Needed for Presentation Easels/Laptop/Projector/Etc.: Easel <input type="checkbox"/> If checked, how many: Laptop <input checked="" type="checkbox"/> Projector <input checked="" type="checkbox"/> Other:		See Additional Summary Attached <input type="checkbox"/>							
SUBMITTER'S RECOMMENDATION(S): Review and discussion of February 2019 AP/PC Register		Submitter's Signature Department Director, Etc. Henry C Low Jr <small>Digitally signed by Henry C Low Jr Date: 2019.03.09 10:37:15 -07'00'</small>							
FINANCE REVIEW Fiscal Impact/Cost: There is no financial impact to Lea County with this agenda item.		Reviewed by Finance Director Henry C Low Jr <small>Digitally signed by Henry C Low Jr Date: 2019.03.09 10:37:56 -07'00'</small>							
LEGAL REVIEW: ByPass Legal Review (Note: Travel does not need legal review)		Reviewed by County Attorney ByPass Legal Review <small>Digitally signed by ByPass Legal Review Date: 2019.03.20 12:50:21 -06'00'</small>							
COUNTY MANAGER REVIEW:		Approved by County Manager to be Placed on Agenda <small>Digitally signed by Michael P. Gallagher II Date: 2019.03.20 12:49:56 -06'00'</small>							
Item 0303 RECORDING SECRETARY'S USE ONLY ~ COMMISSION ACTION TAKEN									
Approved: _____	Denied: _____	Other: <u>Discussion</u>							
Resolution No. _____	Policy No. _____	Ordinance No. _____							
Continued To: _____	Referred To: _____	Comments: _____							

County of Lea New Mexico
Accounts Payable Check Register February 2019

Check #	Check Amount	Check Date	Vendor Name	Transaction Description
1084468	\$ 61.86	2/1/2019	WASHINGTON NATIONAL INS CO	TAI ETCHEVERRY PAYMENT
1084469	\$ 216.19	2/1/2019	STINE, JAMES M	SERVICE CALL & REKEY
1084470	\$ 282.41	2/1/2019	AZTEC RENTAL OF HOBBS LLC	RENTAL PORTABLE RESTROOMS
1084471	\$ 547.50	2/1/2019	APACHE SALES INC	ROPE,WIRE, SWAGE ,BUTTON
1084472	\$ 547.79	2/1/2019	BRUCKNER TRUCK SALES INC	SEALS (3) 175.32
1084473	\$ 55,474.71	2/1/2019	COOPERATIVE EDUCATIONAL SERVICES	CES CONTRACT# 16-01B-R1227-6
1084474	\$ 54,286.94	2/1/2019	COOPERATIVE EDUCATIONAL SERVICES	CES CONTRACT# 16-01B-R1227-6
1084475	\$ 5,372.80	2/1/2019	COOPERATIVE EDUCATIONAL SERVICES	TEMP LABOR ROAD DEPT
1084476	\$ 190.70	2/1/2019	EMPIRE PAPER CO	GLASS CLEANER
1084477	\$ 248.09	2/1/2019	FARMER BROTHERS COMPANY	COFFEE, CUPS
1084478	\$ 595.00	2/1/2019	GOVERNMENT FINANCE OFFICERS	MEMBERSHIP RENEWAL FOR PERIOD
1084479	\$ 158.15	2/1/2019	HOBBS DAILY NEWS-SUN INC	LEGAL NOTICES FOR MEETINGS
1084480	\$ 53.55	2/1/2019	PUGH, HOWELL R	8- 5 GALLON BOTTLE RO WATER FOR
1084481	\$ 155.00	2/1/2019	HOBBS CHAMBER OF COMMERCE INC	COMMISSION
1084482	\$ 700.00	2/1/2019	ICE PLUS	3 - 5 GAL BOTTLED WATER
1084483	\$ 1,468.15	2/1/2019	INTERMOUNTAIN STAFFING LCL INC	LEA COUNTY COURT HOUSE
1084484	\$ 57.59	2/1/2019	4 RIVERS EQUIPMENT, LLC	GASKET, FUEL PUMP
1084485	\$ 15,372.35	2/1/2019	K W FUELS INC	7000 GALLONS CLEAR DIESEL
1084486	\$ 25.52	2/1/2019	LOVINGTON AUTO SUPPLY INC	WINDSHIELD WIPERS G85537 (T1)
1084487	\$ 58.59	2/1/2019	WAL-ROY INC	LEGAL NOTICE DWI ADVISORY COUNCI
1084488	\$ 500.00	2/1/2019	LOVINGTON CHAMBER OF COMMERCE	COMMISSION
1084489	\$ 1,040.00	2/1/2019	NOR-LEA HOSPITAL DISTRICT	LEA COUNTY DIABETES PROGRAM
1084490	\$ 163.29	2/1/2019	NEW MEXICO ONE CALL INC	ANNUAL BASIC MEMBERSHIP FEE 2019
1084491	\$ 25,750.00	2/1/2019	NM STATE UNIVERSITY	SUPPORT OF COOPERATIVE EXTENSION
1084492	\$ 48.93	2/1/2019	O & S QUIK CHANGE, INC	OIL CHANGE UNIT ES1
1084493	\$ 848.68	2/1/2019	SEWCO INC	CALENDAR
1084494	\$ 2,457.74	2/1/2019	PCMG, INC.	ENCRYPTION NVME-DVD-WRITER-UHD
1084495	\$ 71.82	2/1/2019	ROBERTS OIL & LUBE	OIL CHANGES FOR VEHICLES
1084496	\$ 496.09	2/1/2019	RICOH USA INC	RICOH COPIER MONTHLY SERVICE
1084497	\$ 12,759.57	2/1/2019	SUMMIT FOOD SERVICES MGT. LLC	DETAINEE MEALS 4 WEEKS
1084498	\$ 139.16	2/1/2019	STERICYCLE INC	BIO HAZARD WASTE
1084499	\$ 2,500.00	2/1/2019	SALVATION ARMY HOBBS CORP	PROFESSIONAL SERVICES RENDERED
1084500	\$ 989.40	2/1/2019	SHARE CORPORATION	RUN A BACTERIA TEST ON
1084501	\$ 701.76	2/1/2019	TAYLOR'S WEED & PEST CONTROL	WEED AND PEST CONTROL
1084502	\$ 21,875.00	2/1/2019	TOWN OF TATUM	2ND QTR FY 2018-19
1084503	\$ 15.83	2/1/2019	TASCOSA OFFICE MACHINES	HB0205 B\W & COLOR METER READ
1084504	\$ 513.46	2/1/2019	VERIZON WIRELESS	ACCT 242177366-00001
1084505	\$ 253.00	2/1/2019	W D ENTERPRISES INC	UNIT 16 BATTERY
1084506	\$ 2,600.30	2/1/2019	WATSON TRUCK & SUPPLY INC	SEAL ASSY OIL FRT WHL, DRUM FRON
1084507	\$ 21,812.80	2/1/2019	WINDSTREAM	ACCT# 100171271
1084508	\$ 345.90	2/1/2019	PROFESSIONAL COMMUNICATIONS	RADIO INSTALLATION & ANTENNA
1084509	\$ 74.96	2/1/2019	AMERICA SUPPLY, LLC	SPRAYWAY ,COPY PAPER, SUGAR
1084510	\$ 405.89	2/1/2019	WAGNER EQUIPMENT CO	TROUBLESHOOT ENGINE FOR CHIPPER
1084511	\$ 10,551.27	2/1/2019	DELL MARKETING LP	DELL EMC NX3240 NAS DEVICE
1084512	\$ 628.93	2/1/2019	ASC IRRIGATION & REPAIR	EST TO DIG UP BOTH SIDES OF THE
1084513	\$ 132.00	2/1/2019	JONES, DON	COMMISSION
1084515	\$ 1,084.46	2/4/2019	LEA COUNTY ELECTRIC COOP	ACCT# 14614002
1084516	\$ 212.56	2/4/2019	PENNEL, ROBERT C	BENDER BILLBOARD FEBRUARY 2019
1084517	\$ 50.91	2/4/2019	SHERWIN WILLIAMS INC	METAL PAINT FOR CONCOURSE DOORS
1084518	\$ 466.99	2/4/2019	AMERIPRIDE SERVICES	NAPKIN, TABLECLOTH RENTAL
1084519	\$ 2,683.80	2/4/2019	TEEN COURT OF LEA COUNTY	SOUTH/NORTH CONCESSIONS
1084520	\$ 654.03	2/4/2019	SHARE CORPORATION	CHEMICAL TO CLEAR KITCHEN DRAINS
1084521	\$ 500.00	2/4/2019	LEADERSHIP NEW MEXICO	NM LOCAL GOVERNMENT LEADERSHIP
1084522	\$ 367.51	2/4/2019	WAL-ROY INC	COMMISSION
1084523	\$ 175.00	2/4/2019	JAL RECORD	COMMISSION
1084524	\$ 97.35	2/4/2019	GEOTEL CORPORATION	LC WATER USERS ASSOCIATION
1084525	\$ 507.52	2/4/2019	WINDSTREAM	ACCT 100220015
1084526	\$ 183.55	2/4/2019	WINDSTREAM	ACCT# 100912151

County of Lea New Mexico
Accounts Payable Check Register February 2019

Check #	Check Amount	Check Date	Vendor Name	Transaction Description
1084527	\$ 111.19	2/4/2019	WINDSTREAM	ACCT# 101056635
1084528	\$ 234.81	2/4/2019	WINDSTREAM	ACCT# 100784081
1084529	\$ 964.54	2/4/2019	WINDSTREAM	ACCT# 100911873
1084530	\$ 96.41	2/4/2019	SOUTHWESTERN PUBLIC SERVICE COMP	ACCT# 54-9312865-5
1084531	\$ 1,386.18	2/4/2019	BLAINE INDUSTRIAL SUPPLY INC	TISSUE, GLOVES, FOGGERS, PLATES,
1084532	\$ 59.90	2/4/2019	LOBO NUT & BOLT INC	TANGO RECHARGE WORK LITE SPOT
1084533	\$ 349.70	2/4/2019	O'REILLY AUTO	BRAKE CLEAN - (130 COUNT)
1084534	\$ 928.97	2/4/2019	THIRTEEN TWENTY LLC	TRANSMISSION FRONT SEAL REPAIRS
1084535	\$ 1,735.12	2/4/2019	MYERS TIRE SUPPLY	VALVE CAP, VALVE CORE, FAST FLOW
1084536	\$ 105.50	2/4/2019	MESCALERO RIDGE WATER COOP INC	UTILITIES FEB 2019
1084537	\$ 19,965.00	2/4/2019	TB TRAILER SALES LLC	102"X30' BUMPER PULL DECKOVER
1084538	\$ 558.59	2/4/2019	LL&D, INC	#NAME?
1084539	\$ 271.10	2/6/2019	AMERIPRIDE SERVICES	NAPKIN, TABLECLOTH RENTAL
1084540	\$ 197.89	2/6/2019	AMAZON CAPITAL SERVICES, INC	(3) GUN HOLSTERS
1084541	\$ 239.71	2/6/2019	AMERICA SUPPLY, LLC	PERFORMANCE TOOL TAPE MEASURE,
1084542	\$ 143.02	2/6/2019	BENCHMARK BUSINESS SOLUTIONS, INC	ACCT# LC25
1084543	\$ 353.01	2/6/2019	BLAINE INDUSTRIAL SUPPLY INC	CUST# 17849
1084544	\$ 4,732.90	2/6/2019	CODE 3 SERVICE LLC	(3) SIERRA WIRELESS MP70
1084545	\$ 95.00	2/6/2019	DOLAN CONSULTING GROUP LLC	BACKGROUND INVESTIGATIONS IN
1084546	\$ 158.14	2/6/2019	DISH NETWORK	ACCT# 8255 7070 8613 6053
1084547	\$ 394.02	2/6/2019	FARMER BROTHERS COMPANY	COFFEE, CREAMER, SUGAR, HOT COCOA
1084548	\$ 135.50	2/6/2019	GENERAL WELDING SUPPLY INC	CYLINDER EXCHANGES
1084549	\$ 81.95	2/6/2019	HIGGINBOTHAM-BARTLETT COMPANY	BALL VALVE
1084550	\$ 1,229.45	2/6/2019	HIGGINBOTHAM-BARTLETT CO NM INC	8"40# TENSIL LTDUTY BLK, BLOWOFF
1084551	\$ 6,148.82	2/6/2019	KLEIN AUTOMATION & ELECTRIC INC	CARD ACCESS COMMUNITY CENTERS
1084552	\$ 456.60	2/6/2019	LAW ENFORCEMENT TARGETS INC	(1000) SKILL BUILDER ANATOMICAL
1084553	\$ 50.00	2/6/2019	WAL-ROY INC	EXECUTIVE
1084554	\$ 18,551.59	2/6/2019	LEA COUNTY ELECTRIC COOP	ACCT# 851
1084555	\$ 130.20	2/6/2019	NOR-LEA HOSPITAL DISTRICT	ACCT#10287224
1084556	\$ 3,455.31	2/6/2019	NOR-LEA HOSPITAL DISTRICT	ACCT#666515
1084557	\$ 88.90	2/6/2019	NOR-LEA HOSPITAL DISTRICT	ACCT#10294370
1084558	\$ 130.20	2/6/2019	NOR-LEA HOSPITAL DISTRICT	ACCT# 10291176
1084559	\$ 435.55	2/6/2019	SPEAKWRITE	TRANSCRIPTION SERVICES
1084560	\$ 301.00	2/6/2019	TRANSUNION RISK & ALTERNATIVE	ACCT ID: 424646
1084561	\$ 234.87	2/6/2019	UNIFIRST CORPORATION	FLOOR MATS AND MOPHEADS
1084562	\$ 127.52	2/6/2019	VERIZON WIRELESS	ACCT 842219948-00001
1084563	\$ 2,559.53	2/6/2019	XEROX CORPORATION	SER# BGO-960037
1084564	\$ 52.80	2/6/2019	YUCCA TELECOM	ACCT# 1607
1084565	\$ 333.14	2/6/2019	ZIA NATURAL GAS COMPANY	CUST# 2108677-01
1084566	\$ 55.33	2/6/2019	WINDSTREAM	ACCT# 100824550
1084567	\$ 55.48	2/6/2019	WINDSTREAM	ACCT# 100738250
1084568	\$ 122.08	2/6/2019	WINDSTREAM	ACCT# 101078116
1084569	\$ 5,750.00	2/6/2019	THIRTEEN TWENTY LLC	1-BED FOR TRUCK #72 & INSTALL
1084570	\$ 1,460.00	2/6/2019	TECHNICON TRAINING & CONS SER	FIELD TRAINING OFFICER TRAINING
1084571	\$ 25.00	2/6/2019	SECRETARY OF STATE	FEE FOR FILING ARTICLES OF
1084572	\$ 2,360.00	2/6/2019	NOR-LEA HOSPITAL DISTRICT	EMPLOYEE PHYSICALS
1084573	\$ 1,119.92	2/6/2019	BRADBURN, RONALD	ANNUAL INSPECTION FIRE EXTINGUIS
1084574	\$ 744.41	2/6/2019	LOVINGTON AUTO SUPPLY INC	FUEL FIL, NAPA HAND CLEANER
1084575	\$ 315.00	2/6/2019	MONUMENT MUTUAL DOMESTIC WATER	UTILITIES JAN 2019
1084576	\$ 2,527.05	2/6/2019	INTERMOUNTAIN STAFFING LCL INC	LEA COUNTY COURT HOUSE
1084628	\$ 16,111.98	2/8/2019	BAZAAR UNIFORMS & MENS STORE LLC	PROPPER POLO SHIRTS, MEN/WOMEN
1084629	\$ 1,110.00	2/8/2019	SEWCO INC	CLOROX WIPES, FACIAL TISSUE,
1084630	\$ 3,251.23	2/8/2019	INSITE TOWERS LLC	LEASE ID# 004759
1084631	\$ 500.00	2/8/2019	SBA TOWERS II LLC	CUST# NM11964-A-03
1084632	\$ 2,190.49	2/8/2019	TDS	ACCT# 8224 20 004 0141367
1084633	\$ 3,800.00	2/8/2019	PROFESSIONAL COMMUNICATIONS	ETHERNET LINK HOBBS/JAL WEST
1084634	\$ 100.00	2/8/2019	WATTS, ROBERT L	PRE EMPLOYMENT POLYGRAPH EXAM
1084635	\$ 12,818.48	2/8/2019	SUMMIT FOOD SERVICES MGT. LLC	INMATE MEALS 4 WEEKS

County of Lea New Mexico
Accounts Payable Check Register February 2019

Check #	Check Amount	Check Date	Vendor Name	Transaction Description
1084636	\$ 1,980.98	2/8/2019	TRIADIC ENTERPRISES INC	CONTRACT CHARGES JAN 2019
1084637	\$ 17,248.28	2/8/2019	SOUTHWESTERN PUBLIC SERVICE COMP	ACCT# 54-1306035-0
1084638	\$ 56.00	2/8/2019	NEW TEX WATER CONDITIONING, LLC	50 LB BAG ROCK SALT, DELIVERY
1084639	\$ 1,010.60	2/8/2019	BLAINE INDUSTRIAL SUPPLY INC	(2)CS TOILET TISSUE
1084640	\$ 1,358.60	2/8/2019	JOHN DEERE FINANCIAL	PANS - AW34217
1084641	\$ 42.49	2/8/2019	WINDSTREAM	ACCT# 100227373
1084642	\$ 473.19	2/8/2019	WINDSTREAM	ACCT# 100945613
1084643	\$ 201.93	2/8/2019	WINDSTREAM	ACCT# 100919084
1084644	\$ 121.52	2/8/2019	UNIFIRST CORPORATION	FLOOR MATS AND MOPHEADS
1084645	\$ 15,397.23	2/8/2019	CPI TELECOM	VOICE SWITCH RACK MOUNT,SITE LIC
1084646	\$ 388.67	2/8/2019	SHERWIN WILLIAMS INC	5 - 5-GAL SIZE PAINT,TAPE,PLASTC
1084647	\$ 2,118.79	2/8/2019	LEACO RURAL TELEPHONE	ACCT# 00034904-4 FEB 2019
1084648	\$ 78.28	2/8/2019	HOBBS DAILY NEWS-SUN INC	LEGAL NOTICE FOR LEA CO FIRE
1084649	\$ 30,679.58	2/8/2019	INTERMOUNTAIN STAFFING LCL INC	TEMP WORK LEA COUNTY CLEANUP
1084650	\$ 1,034.75	2/8/2019	TOP HAND, LLC	REPAIRS TO UNIT 315 FOR MALJAMAR
1084651	\$ 13.04	2/8/2019	HOSE POWER USA	FEMALE CAM SHANK, MALE CAM SHANK
1084652	\$ 467.98	2/8/2019	AMERICA SUPPLY, LLC	HAND CLEANER, GLASS CLEANER,SAFE
1084653	\$ 123,730.87	2/8/2019	CAMINO REAL ENVIRONMENTAL	8858.04 TONS JAN 2019
1084654	\$ 165.98	2/8/2019	ADVANCE STORES COMPANY INC	PWR INVERTR CEC
1084655	\$ 500.00	2/8/2019	CAROLINA SOFTWARE, INC	WASTEWORX SOFTWARE SUPPORT
1084656	\$ 16,075.28	2/8/2019	GARY'S HEATING & AIRCONDITIONING	INSTALLATION OF ARMSTRONG 3-TON
1084657	\$ 143.48	2/8/2019	WATER PROCESSING	REVERSE OSMOSIS- MONUMENT FIRE
1084658	\$ 4,165.00	2/8/2019	GALYEAN JAYDEN	JUNIOR LIVESTOCK SALE
1084659	\$ 15,092.72	2/8/2019	TAXATION & REVENUE DEPARTMENT	GROSS RECEIPTS JAN 2019
1084660	\$ 28.00	2/8/2019	CITY OF EUNICE	ACCT# 32395.01
1084661	\$ 9,681.76	2/8/2019	COOPERATIVE EDUCATIONAL SERVICES	1680 LF - RECONST 17TH STREET -
1084662	\$ 332,954.40	2/8/2019	COOPERATIVE EDUCATIONAL SERVICES	ELECT WORK TO RELOCATE UNDER-
1084663	\$ 4,975.16	2/8/2019	COOPERATIVE EDUCATIONAL SERVICES	CENTRAL & LOVE STREET UPGRADE IN
1084664	\$ 14,622.85	2/8/2019	COOPERATIVE EDUCATIONAL SERVICES	RETERMINATE, REPAIR & TEST FIBER
1084665	\$ 34,825.67	2/8/2019	COOPERATIVE EDUCATIONAL SERVICES	COURTHOUSE - LOVINGTON
1084666	\$ 131,582.47	2/11/2019	IPR LTD	Z.FRANKLIN MEM AP-PAVEMENT MAINT
1084667	\$ 30,611.02	2/11/2019	RMKM ARCHITECTURE, PC	JUD COMPLEX - BAL DUE CONST ADMN
1084668	\$ 16,846.71	2/11/2019	RMKM ARCHITECTURE, PC	JUD.COMPLEX ARCHITECT - REIMB
1084674	\$ 165.00	2/12/2019	AXON ENTERPRISE, INC	(5) SETS TRAINING TARGETS
1084675	\$ 1,348.34	2/12/2019	AMAZON CAPITAL SERVICES, INC	(6) PANASONIC CF-VZSU0PW
1084676	\$ 193.87	2/12/2019	BARRON SERVICE PARTS	BOOSPACE
1084677	\$ 343.47	2/12/2019	CERTIFIED AIR CONDITIONING &	ICE MACHINE LEASE PAYMENT
1084678	\$ 718.21	2/12/2019	CITY AUTO GLASS INC	WINDSHIELD TINT,ADHESEIVE 2018
1084679	\$ 1,415.21	2/12/2019	CITY OF HOBBS	UTILITIES/DA'S OFFICE
1084680	\$ 392.55	2/12/2019	CRAIG ELECTRIC CO	NEW TSA SCANNER INSIDE TERMINAL
1084681	\$ 149,400.00	2/12/2019	DAILEY WELLS COMMUNICATIONS	NETWORK SENTRIES PRE-SIMULCAST
1084682	\$ 326.27	2/12/2019	HIGGINBOTHAM-BARTLETT CO NM INC	NIPPLES, ELBOW,
1084683	\$ 153.95	2/12/2019	W D ENTERPRISES INC	FLEET BATTERY UNIT L52
1084684	\$ 350.00	2/12/2019	INVENTORY TRADING COMPANY	(10) WOMENS JACKETS
1084685	\$ 2,415.90	2/12/2019	KLEIN AUTOMATION & ELECTRIC INC	RENEW WARRANTY FOR DNA SOFTWARE
1084686	\$ 316.86	2/12/2019	LOVINGTON AUTO SUPPLY INC	BATTERY, GAS CAN
1084687	\$ 508.06	2/12/2019	WAL-ROY INC	BLACK AND WHITE SANTA DEPUTY,
1084688	\$ 3,060.70	2/12/2019	LEA COUNTY PERINATAL PROGRAM	SERVICES FOR AT RISK PREGNANCIES
1084689	\$ 1,351.18	2/12/2019	MASTER PLUMBERS	BACKFLOW PREVENTOR REPAIR
1084690	\$ 7,251.69	2/12/2019	NM GAS COMPANY INC	ACCT# 075145012-0775575-5
1084691	\$ 331.19	2/12/2019	SEWCO INC	AIR FRESHENER, DUSTERS, SIGNAGE
1084692	\$ 168.73	2/12/2019	O & S QUIK CHANGE, INC	OIL CHANGE UNIT L21
1084693	\$ 645.76	2/12/2019	PRECISION TUNE-UP	FRONT PADS, REAR PADS, RF ROTOR
1084694	\$ 297.15	2/12/2019	PERMIAN AUTO GROUP	DEFROST OPTION NOT WORKING
1084695	\$ 5,118.95	2/12/2019	PCMG, INC.	ACCT# 0165678152
1084696	\$ 25.42	2/12/2019	PUGH, HOWELL R	4 - 5 GAL BOTTLED WATER
1084697	\$ 162.00	2/12/2019	SMARTE CARTE, INC	WHEELCHAIR ACCESS/RENTAL
1084698	\$ 160.22	2/12/2019	ALBERT S KEENAN	PRE-EMPLOYMENT POLYGRAPH

County of Lea New Mexico
Accounts Payable Check Register February 2019

Check #	Check Amount	Check Date	Vendor Name	Transaction Description
1084699	\$ 869.96	2/12/2019	VALENTINE AUTO SERVICE INC	REPAIR HOSE, CONNECTOR, DEXCOOL,
1084700	\$ 642.29	2/12/2019	WINDSTREAM	ACCT# 101020108
1084701	\$ 605.00	2/12/2019	SYMBOLARTS	(6) CHAPLAIN BADGES
1084702	\$ 909.16	2/12/2019	ULINE	WIRE SHELVING (4)
1084703	\$ 307.50	2/12/2019	WORLD ARCHIVES	JAL RECORD JAN-DEC '17 35MM DUPL
1084704	\$ 3,501.00	2/12/2019	WENGER CORPORATION	STAGE LOCKING PINS
1084705	\$ 1,424.25	2/12/2019	YOU BET YOUR GLASS	WINDOW CLEANING IN TERMINAL,
1084706	\$ 6,071.87	2/12/2019	ZIA NATURAL GAS COMPANY	CUST# 2104518-00
1084707	\$ 55.00	2/12/2019	SINGLETON, MICHAEL	FIRE CHIEF ADVISORY BOARD
1084708	\$ 215.72	2/12/2019	WINDSTREAM	ACCT# 100212368
1084709	\$ 116.26	2/12/2019	SOUTHWESTERN PUBLIC SERVICE COMP	ACCT# 54-1853312-5
1084710	\$ 127.21	2/12/2019	SOUTHWESTERN PUBLIC SERVICE COMP	ACCT# 54-1554334-7
1084711	\$ 437.85	2/12/2019	VERIZON WIRELESS	ACCT# 742111570-00001
1084712	\$ 16.91	2/12/2019	CITY OF HOBBS	ACCT# 016660-000
1084713	\$ 132.79	2/12/2019	CITY OF HOBBS	ACCT# 016659-000
1084714	\$ 181.53	2/12/2019	TDS	ACCT# 8224 20 004 0132168
1084715	\$ 11.99	2/12/2019	ZIA NATURAL GAS COMPANY	CUST# 2105608-00
1084716	\$ 77.09	2/12/2019	ZIA NATURAL GAS COMPANY	ACCT# 2105296-00
1084717	\$ 48.26	2/12/2019	FORREST TIRE COMPANY INC	MANLIFT TIRE REPAIR
1084718	\$ 36.75	2/12/2019	CITY OF JAL	ACCT# 4052100.01
1084719	\$ 590.08	2/12/2019	SOUTHWESTERN PUBLIC SERVICE COMP	ACCT# 54-9476516-9
1084720	\$ 400.00	2/12/2019	CITY OF HOBBS	R CALLAHAN BURIAL
1084721	\$ 600.00	2/12/2019	LEGACY FUNERAL SERVICES OF NM LL	R CALLAHAN BURIAL
1084722	\$ 1,200.00	2/12/2019	MEMORY GARDENS	K BUCY BURIAL
1084723	\$ 600.00	2/12/2019	GRIFFIN FUNERAL HOME INC	L BURNS CREMATION
1084724	\$ 109.64	2/12/2019	FEDERAL EXPRESS CORPORATION	FEDEX 2 DAY TO NMDOT AVIATION
1084725	\$ 856.00	2/12/2019	SUNGUARD PRECISION LLC	WHEEL GUARD FOR THE MAINT
1084726	\$ 6,464.24	2/12/2019	ECONOMIC DEVELOPMENT CORP LEA CO	NM DOT AIRLINE MARKETING GRANT
1084727	\$ 150.00	2/12/2019	EUNICE CHAMBER OF COMMERCE	COMMISSION
1084728	\$ 1,331.37	2/13/2019	ROBERTS OIL & LUBE	OIL CHANGE, AIR FILTER UNIT L15
1084729	\$ 825.44	2/13/2019	O & S QUIK CHANGE, INC	OIL CHANGE UNIT L54
1084730	\$ 7,000.00	2/13/2019	CITY OF HOBBS	DA'S OFFICE LEASE FEB 2019
1084731	\$ 93.67	2/13/2019	DIRECTV LLC	ACCT# 007920019
1084732	\$ 167.70	2/13/2019	LEA COUNTY TREASURER	JAN 2019 MONTHLY CC FEES
1084733	\$ 285.00	2/13/2019	MERCEDES MEDICAL, LLC	FUO LAB CUPS
1084734	\$ 69.00	2/13/2019	VITAL RECORDS, HOLDINGS, LLC	DOCUMENT SHREDDING
1084735	\$ 135,782.93	2/13/2019	COOPERATIVE EDUCATIONAL SERVICES	GARY LANE PROJECT, INCL GEN RE-
1084736	\$ 132,257.60	2/13/2019	COOPERATIVE EDUCATIONAL SERVICES	ROBERTS LANE RECONSTRUCTION -
1084737	\$ 20,948.95	2/13/2019	CONSTRUCTORS INC	1500 TONS OF BASE COURSE
1084738	\$ 7,174.74	2/13/2019	MOLZEN-CORBIN & ASSOCIATES	DESIGN BENNETT COLONIA WATER SYS
1084739	\$ 90,918.73	2/13/2019	PCMG, INC.	(5) PRODESK400 COMPUTERS,
1084740	\$ 181,031.67	2/13/2019	LASCO CONSTRUCTION INC	LC REG AIRPORT - TERMINAL EXPANS
1084741	\$ 978.90	2/13/2019	TOWN OF TATUM	REIMBURSE TOWN OF TATUM PER
1084742	\$ 19,410.00	2/13/2019	WATCHGUARD VIDEO	(3) IN CAR VIDEO SYSTEMS FOR NEW
1084743	\$ 566.34	2/13/2019	TRAVELERS	ACCT# 5478K5083
1084744	\$ 809.38	2/13/2019	THOMSON REUTERS	WEST INFORMATION CHARGES
1084745	\$ 5,222.84	2/14/2019	LOVINGTON WELLNESS CENTER	DECEMBER INVOICE #1
1084748	\$ 2,159.64	2/15/2019	ABACUS DATA SYSTEM, INC	ABACUS LAW USER
1084749	\$ 1,229.91	2/15/2019	AMERICA SUPPLY, LLC	BRASS COMBINATION LOCK, 8-PIN
1084750	\$ 1,110.96	2/15/2019	BLAINE INDUSTRIAL SUPPLY INC	RAGS, COLOR KNIT (108 BG)
1084751	\$ 4,365.34	2/15/2019	BRUCKNER TRUCK SALES INC	DASH CONT 246.61
1084752	\$ 22,103.08	2/15/2019	COOPERATIVE EDUCATIONAL SERVICES	CHAPARRAL BUILDING ROOF REPAIRS
1084753	\$ 5,293.20	2/15/2019	COOPERATIVE EDUCATIONAL SERVICES	TEMP LABOR ROAD DEPT
1084754	\$ 452.02	2/15/2019	COMPUSYS, INC	COBRA ADMINISRATION FEES
1084755	\$ 234.95	2/15/2019	CITY AUTO GLASS INC	SAFETY LAMINATED, URTHENE,TRIP
1084756	\$ 4,352.65	2/15/2019	FORREST TIRE COMPANY INC	M3 & M4 MOWER TIRES, FLAT REPAIR
1084757	\$ 317.09	2/15/2019	FARMER BROTHERS COMPANY	COFFEE, CREAMER, SUGAR,CUPS
1084758	\$ 214.20	2/15/2019	GET-A-GRIP SUPPLIES	3DZ GLOVES,3DZ SAFETY GLASSES

County of Lea New Mexico
Accounts Payable Check Register February 2019

Check #	Check Amount	Check Date	Vendor Name	Transaction Description
1084759	\$ 17.60	2/15/2019	HIGGINBOTHAM-BARTLETT COMPANY	HEX CAP, LOCK NUT,FLAT WASH,
1084760	\$ 6,750.60	2/15/2019	HOBBS IRON & METAL	TIRE DISPOSAL FEE
1084761	\$ 1,500.00	2/15/2019	INTRADYN	ANNUAL SUPPORT INTRADYN SERVER
1084762	\$ 1,680.00	2/15/2019	INTERMOUNTAIN STAFFING LCL INC	TEMP WORK LEA COUNTY ROAD DEPT
1084763	\$ 57.59	2/15/2019	4 RIVERS EQUIPMENT, LLC	GASKET, FUEL PUMP
1084764	\$ 14,482.88	2/15/2019	K W FUELS INC	FUEL & PROPANE FOR
1084765	\$ 479.58	2/15/2019	LOVINGTON AUTO SUPPLY INC	MALJAMAR FD
1084766	\$ 34.00	2/15/2019	LUBBOCK DIAGNOSTIC RADIOLOGY	ACCT# 54971933805
1084767	\$ 5,073.89	2/15/2019	MONTGOMERY & ANDREWS, PA	PROFESSIONAL SERVICES RENDERED
1084768	\$ 501.57	2/15/2019	MC COOL'S AIR TECH	LIQUID LINE, FREON, OIL CHARGE
1084769	\$ 7,894.75	2/15/2019	NOVATIME TECHNOLOGY INC	3 NT7000 TIMECLOCK TERMINALS
1084770	\$ 323.16	2/15/2019	O & S QUIK CHANGE, INC	OIL CHANGE, WASH UNIT 207WGB
1084771	\$ 1,222.17	2/15/2019	SEWCO INC	INK CARTRIDGES AND LABELS
1084772	\$ 1,304.47	2/15/2019	PARTS PLUS	2 GAGUE X20 BOOSTER
1084773	\$ 1,116.85	2/15/2019	PC AUTOMATED CONTROLS, INC	CONTRACT NO: C0041
1084774	\$ 150.00	2/15/2019	PRICE, MARLA	1 COMPLETE SET OF LOGOS W/2
1084775	\$ 297.73	2/15/2019	RICOH USA INC	RICOH MPC4501A COPIER
1084776	\$ 4,573.50	2/15/2019	SURVIVAL ARMOR INC	6 BLS2-LL, 1 CARRIER, & STP
1084777	\$ 1,445.00	2/15/2019	SUNGUARD PRECISION LLC	5-VEHICLE SYSTEM 2012 DODGE RAM
1084778	\$ 599.84	2/15/2019	SHERWIN WILLIAMS INC	PAINT, (15 - 5 GAL) TIP
1084779	\$ 13,195.96	2/15/2019	LEA COUNTY SOLID WASTE AUTHORITY	N HOBBS TRANSFER
1084780	\$ 160.80	2/15/2019	TRIADIC ENTERPRISES INC	36 RIBBONS FOR RECORDING LABELS
1084781	\$ 317.80	2/15/2019	W D ENTERPRISES INC	FLEET BATTERIES (2), AA/AAA
1084782	\$ 1,335.15	2/15/2019	WATTS, ROBERT L	PREEMPLOYMENT POLY
1084783	\$ 23,826.98	2/15/2019	WASTE MANAGEMENT OF NEW MEXICO	ACCT# 2-40543-24002
1084784	\$ 286.96	2/15/2019	WATER PROCESSING	RENTAL OF UV LIGHT & REVERSE
1084785	\$ 5,244.50	2/15/2019	AMERICAN MEDICAL GROUP, INC	PREEMPLOYMENT AND RANDOM SCREEN
1084786	\$ 12,797.30	2/15/2019	SUMMIT FOOD SERVICES MGT. LLC	INMATE MEALS 4 WEEKS
1084787	\$ 35,535.40	2/15/2019	WEX BANK	ACCT# 0432-00-388144-8
1084788	\$ 39.25	2/15/2019	HOBBS DAILY NEWS-SUN INC	LCFRB LEGAL NOTICE
1084789	\$ 17.00	2/15/2019	GENERAL WELDING SUPPLY INC	ONE MONTHS CYLINDER RENTAL (2)
1084790	\$ 465.34	2/15/2019	WINDSTREAM	ACCT# 100635954
1084791	\$ 143.63	2/15/2019	WINDSTREAM	ACCT# 101035209
1084792	\$ 392.24	2/15/2019	WINDSTREAM	ACCT# 100884054
1084794	\$ 722.00	2/19/2019	NM COMPILATION COMMISSION	FY 2019 NMONESOURCE.COM WITH NM
1084795	\$ 7,350.27	2/19/2019	USDA/APHIS/WS	PERSONNEL COMPENSATION
1084796	\$ 239.72	2/19/2019	TRUCKPRO, LLC	UNIT T-9 ,RELAY, RELAY VALVE,
1084797	\$ 139.00	2/19/2019	COHAGEN, NICKI	1000 ENVELOPES -REGULAR #10
1084798	\$ 4,200.00	2/19/2019	MCMILLIAN CONSULTING	REMOTE SET UP AND CONFIGURATION,
1084799	\$ 16,546.13	2/19/2019	G & G ROOFING INC	ROOF REPAIR AT FAIRGROUNDS
1084800	\$ 6,971.25	2/19/2019	GWC CONSTRUCTION INC	DEMO 1000 SQFT CONCRET GSB
1084801	\$ 1,178.53	2/19/2019	HOBBS DAILY NEWS-SUN INC	COMMISSION
1084802	\$ 115.13	2/19/2019	APACHE SALES INC	DOLLY, CASTER
1084803	\$ 200.00	2/19/2019	NMPPA	NMPPA SPRING 2019 CONFERENCE
1084804	\$ 84.48	2/19/2019	CARLSBAD CURRENT-ARGUS	ACCT# C04598
1084805	\$ 55.00	2/19/2019	BUTTS MARCY	FAIR & RODEO BOARD FEBRUARY MTG
1084806	\$ 55.00	2/19/2019	FLEMENS VIVIAN	FAIR & RODEO BOARD FEBRUARY MTG
1084807	\$ 55.00	2/19/2019	POINTER, BRIAN W	FAIR & RODEO BOARD FEBRUARY MTG
1084808	\$ 55.00	2/19/2019	SCHAAP, RICK	FAIR & RODEO BOARD FEBRUARY MTG
1084809	\$ 55.00	2/19/2019	ALLEN KRIS	FAIR & RODEO BOARD JANUARY MTG
1084810	\$ 55.00	2/19/2019	SIMS PATRICK GEORGE	FAIR & RODEO BOARD FEBRUARY MTG
1084811	\$ 55.00	2/19/2019	KERBY TREYSON	FAIR & RODEO BOARD FEBRUARY MTG
1084812	\$ 55.00	2/19/2019	WHEELER LARRY	FAIR & RODEO BOARD FEBRUARY MTG
1084813	\$ 6,436.50	2/19/2019	APPLIED CONCEPTS, INC	(3) RADAR FOR NEW UNITS
1084814	\$ 2,325.58	2/19/2019	FORREST TIRE COMPANY INC	TIRES, DISPOSAL, BALANCE,MONITOR
1084815	\$ 1,856.71	2/19/2019	TASCOSA OFFICE MACHINES	CUSTOME STAMP TAG
1084816	\$ 920.37	2/19/2019	GALLS LLC	(10) BADGE HOLODERS,(6) LATENT
1084817	\$ 178.20	2/19/2019	SENIORS STANDING STRONG	SENIORS CONFIDENTAL MAGAZINE

County of Lea New Mexico
Accounts Payable Check Register February 2019

Check #	Check Amount	Check Date	Vendor Name	Transaction Description
1084818	\$ 550.00	2/20/2019	ZIA CONSULTING INC	PRE EMPLOYMENT PSYC EVAL FEE
1084819	\$ 682.86	2/21/2019	AMERIPRIDE SERVICES	FLOOR MAT CLEANING SERVICE
1084820	\$ 1,755.00	2/21/2019	BORDER STATES LAWN & PEST CONTR	ONE TIME PRE EMERGENT
1084821	\$ 299.13	2/21/2019	BLAINE INDUSTRIAL SUPPLY INC	FLOOR WAX
1084822	\$ 84.14	2/21/2019	CABALLERO, OSCAR	EXTRACTED BROKEN KEY/SERVICE
1084823	\$ 79.13	2/21/2019	CRAIG ELECTRIC CO	WORK ON PUMPS AT HOB AIRPORT
1084824	\$ 233.55	2/21/2019	GALLS LLC	MENS TWILL PANT, TROUSERS, VELCR
1084825	\$ 7,498.28	2/21/2019	INTERMOUNTAIN STAFFING LCL INC	TEMP LABOR EVENT CENTER
1084826	\$ 25.00	2/21/2019	LEA COUNTY CLERK	STATE OF NM JUDGEMENT FEES
1084827	\$ 262,826.48	2/21/2019	KYRISH GOVERNMENT GROUP	1 - 2018 BUSHMASTER TYPE 4
1084828	\$ 500.85	2/21/2019	LEA COUNTY ELECTRIC COOP	ACCT# 35387
1084829	\$ 92.75	2/21/2019	LEA COUNTY TREASURER	FEES FOR BANK CARD PAYMENTS MADE
1084830	\$ 130.38	2/21/2019	LEACO RURAL TELEPHONE	ACCT# 00000136-3 2/1/19
1084831	\$ 727.82	2/21/2019	LOWE'S HOME CENTERS INC	ACCT 9800 424067 1
1084832	\$ 482.63	2/21/2019	MAHAN, LARRY	REMOVE ADHESIVE ON 2016 FORD
1084833	\$ 7.85	2/21/2019	MAIL SERVICES ETC	CERTIFIED MAIL FEES
1084834	\$ 73,217.76	2/21/2019	NOR-LEA HOSPITAL DISTRICT	MEDICAL SERVICES PROVIDED TO
1084835	\$ 824.60	2/21/2019	NOR-LEA HOSPITAL DISTRICT	ACCT# 10294150
1084836	\$ 216.08	2/21/2019	NM GAS COMPANY INC	ACCT# 074722112-0771346-4
1084837	\$ 132.84	2/21/2019	O & S QUIK CHANGE, INC	OIL CHANGE, WASH,AIR FILTER
1084838	\$ 26.91	2/21/2019	ALCOHOL MONITORING SYSTEMS INC	GPS CDMA REPLACEMENT KIT
1084839	\$ 208.99	2/21/2019	PITNEY BOWES BANK INC	ACCT 8000-9000-0175-4690
1084840	\$ 339.12	2/21/2019	PITNEY BOWES INC	COURTHOUSE POSTAGE MACH SUPPLIES
1084841	\$ 7,992.00	2/21/2019	ROBINSON AVIATION (RVA), INC	ATC SERVICES JAN 2019
1084842	\$ 315.00	2/21/2019	REDWOOD TOXICOLOGY LABORATORY	ACCT# 115754
1084843	\$ 2,308.22	2/21/2019	TAYLOR'S WEED & PEST CONTROL	PEST CONTROL SERVICE
1084844	\$ 1,915.83	2/21/2019	TOTAL MAINTENANCE SOLUTIONS	PLUMBING SUPPLIES, FILLER VALVE,
1084845	\$ 804.38	2/21/2019	GREASEBUSTERS OF THE SOUTHWEST	QUARTERLY SERVICE - KITCHEN
1084846	\$ 291.26	2/21/2019	VENTANAS COMPUTER SYSTEMS, INC	SET UP OF IPSEC SITE TO SITE
1084847	\$ 313.49	2/21/2019	HERITAGE FOOD SERVICE GROUP, INC	GAS TUBE TILLET SKILLET
1084848	\$ 1,042.87	2/21/2019	SEWCO INC	LEGAL PADS, FILE FOLDERS, TAPE
1084849	\$ 64.65	2/21/2019	WINDSTREAM	ACCT 101078010
1084850	\$ 1,022.51	2/21/2019	WASTE MANAGEMENT OF NEW MEXICO	ACCT# 2-13319-84008
1084851	\$ 10.95	2/21/2019	ZIA NATURAL GAS COMPANY	CUST# 2104606-00
1084852	\$ 19.32	2/21/2019	LEYVA CHRISTOPHER	DEA DEBRIEF TFI18062232
1084853	\$ 1,109.70	2/21/2019	WINDSTREAM	ACCT# 101020894
1084901	\$ 100.00	2/22/2019	LILES JENNIFER	REIMBURSEMENT FOR GARNISHMENT
1084902	\$ 507.23	2/22/2019	OFFICE OF THE ATTORNEY GENERAL	CHILDSUP DED 02/22/2019
1084903	\$ 225.45	2/22/2019	BOLIN, DANIEL	REIMBURSEMENT FOR GARNISHMENT
1084904	\$ 55.00	2/22/2019	ACOSTA ANA M	2/21/19 LEA CO BOARD OF REGIST.
1084905	\$ 55.00	2/22/2019	SELBY, CAROLYN	2/21/19 LEA CO BOARD OF REGIST.
1084906	\$ 74.36	2/22/2019	AYERS, JOHN	2/21/19 LEA CO BOARD OF REGIST.
1084907	\$ 2,549.51	2/22/2019	AMERICA SUPPLY, LLC	AMERICIAN LOCK ALUMINUM SHACKLE,
1084908	\$ 271.10	2/22/2019	AMERIPRIDE SERVICES	FLOOR MAT CLEANING SERVICE
1084909	\$ 165.22	2/22/2019	WASTE MANAGEMENT OF NEW MEXICO	CUST ID: 2-40546-24009
1084910	\$ 296.79	2/22/2019	FARMER BROTHERS COMPANY	CREAMER, CUPS , COFFEE
1084911	\$ 379.80	2/22/2019	GWC CONSTRUCTION INC	WASTE DISPOSAL 1/24/19
1084912	\$ 108.57	2/22/2019	HIGGINBOTHAM-BARTLETT CO NM INC	STAKE RND W/HOLE
1084913	\$ 26.16	2/22/2019	HIGGINBOTHAM-BARTLETT COMPANY	RING WAX BOWL, FLANGE, BOLT SET
1084914	\$ 154.70	2/22/2019	PUGH, HOWELL R	19 - 5 GAL BOTTLE WATER
1084915	\$ 267.03	2/22/2019	WATTS, ROBERT L	PRE EMPLOYMENT POLYGRAPH EXAM
1084916	\$ 1,969.96	2/22/2019	P & D PETROLEUM WHOLESALE	PROPANE-LPG & CALL OUT FEE
1084917	\$ 177.26	2/22/2019	WAL-ROY INC	LEGAL NOTICE FOR LCMC
1084918	\$ 60.00	2/22/2019	K W FUELS INC	PROPANE FOR CONV CENTER
1084919	\$ 13,209.09	2/22/2019	INTERMOUNTAIN STAFFING LCL INC	LEA COUNTY AIRPORT/FIRE STATION
1084920	\$ 161.11	2/22/2019	4 RIVERS EQUIPMENT, LLC	HYDRAULIC HOSE & HOSE FITTINGS
1084921	\$ 149.13	2/22/2019	CITY OF LOVINGTON	REIMBURSEMENT/OVERTIME FOR C
1084922	\$ 223.24	2/22/2019	SUNGUARD PRECISION LLC	WINDOW TINT FOR 2016 FORD

County of Lea New Mexico
Accounts Payable Check Register February 2019

Check #	Check Amount	Check Date	Vendor Name	Transaction Description
1084923	\$ 8,727.73	2/22/2019	MOLZEN-CORBIN & ASSOCIATES	ENG -ZIP FRANKLIN PAVEMENT REHAB
1084924	\$ 250.18	2/22/2019	SEWCO INC	MAGENTA INK CARTRIDGE
1084925	\$ 4,662.75	2/22/2019	PROFESSIONAL COMMUNICATIONS	TRAVEL TO JAL WEST SITE TO
1084926	\$ 606.89	2/22/2019	RICOH USA INC	RICOH MPC4504EX COPIER
1084927	\$ 3,709.63	2/22/2019	STRONG POWER ELECTRIC LLC	LIGHT INSTALL COURTHOUSE EXTERIO
1084928	\$ 13,036.46	2/22/2019	SUMMIT FOOD SERVICES MGT. LLC	INMATE MEALS 4 WEEKS
1084929	\$ 227.61	2/22/2019	TASCOSA OFFICE MACHINES	ACCT HB0045
1084930	\$ 251.54	2/22/2019	UNIFIRST CORPORATION	MICROFIB TOWEL
1084931	\$ 218.55	2/22/2019	SOUTHWESTERN PUBLIC SERVICE COMP	ACCT# 54-1306035-0 AREA LIGHT
1084932	\$ 169.35	2/22/2019	LEA COUNTY TREASURER	FEBRUARY CREDIT CARD FEES
1084933	\$ 278.65	2/22/2019	SENA JONATHAN	TRAVEL REIMBURSEMENT FOR AN
1084934	\$ 5,565.88	2/26/2019	AT&T MOBILITY	ACCT# 287234700432
1084935	\$ 864.40	2/26/2019	BARRON SERVICE PARTS	OIL FILTER WRENCHS, PIPE WRENCH
1084936	\$ 8,224.66	2/26/2019	BRUCKNER TRUCK SALES INC	#29 REPLACE INJECTOR KIT
1084937	\$ 4,277.96	2/26/2019	CITY OF HOBBS	ACCT# 040256-000
1084938	\$ 33.38	2/26/2019	CITY OF LOVINGTON	ACCT 02-02100-00
1084939	\$ 6,531.91	2/26/2019	CITY OF LOVINGTON	UTILITIES 12/30/18-1/29/19
1084940	\$ 12,270.32	2/26/2019	4 RIVERS EQUIPMENT, LLC	AIR FILTER, OIL FILTER, OCV
1084941	\$ 138.45	2/26/2019	HOBBS DAILY NEWS-SUN INC	ONLINE SUBSCRIPTION 2019-2020
1084942	\$ 110.00	2/26/2019	KIRKMEYER ELECTRIC INC	WIRED CIRCUIT AND CHECKED AMP
1084943	\$ 16,612.50	2/26/2019	K W FUELS INC	7500 GALLONS CLEAR DIESEL
1084944	\$ 3,187.22	2/26/2019	LEA COUNTY PERINATAL PROGRAM	SERVICES FOR AT RISK PREGNANCIES
1084945	\$ 542.00	2/26/2019	MYERS TIRE SUPPLY	AIR HOSE - 3
1084946	\$ 409.79	2/26/2019	SEWCO INC	BINDERS, DIVIDERS, PRINTER
1084947	\$ 3,971.02	2/26/2019	SOUTHWESTERN PUBLIC SERVICE COMP	ACCT# 54-1567030-7
1084948	\$ 28.72	2/26/2019	HOBBS IRON & METAL	ANGLE IRON, STEEL
1084949	\$ 150.00	2/26/2019	SOUTHWEST SAFETY SPECIALISTS	4 YR PLASTIC INSPECTION TAG
1084950	\$ 2,483.59	2/26/2019	TOWN OF TATUM	REIMBURSE TOWN OF TATUM PER
1084951	\$ 12,277.83	2/26/2019	COMMISSIONER OF PUBLIC LANDS	COMMISSION
1084952	\$ 178.20	2/26/2019	SENIORS STANDING STRONG	EXECUTIVE
1084953	\$ 443.18	2/26/2019	PRECISION TUNE-UP	2015 DODGE PICKUP ENGINE LIGHT
1084954	\$ 254.77	2/26/2019	TASCOSA OFFICE MACHINES	ACCT# HB1877
1084957	\$ 29.58	2/27/2019	NM RETIREE HEALTH	ERIC BLAND MATCH
1084958	\$ 12,498.95	2/27/2019	COUNTY OF LINCOLN	G18SN0017A, RFP #6
1084959	\$ 495.93	2/27/2019	CITY OF ALAMOGORDO	G18SN0017A, RFP #6
1084960	\$ 1,158.72	2/27/2019	RUIDOSO DOWNS	G18SN0017A, RFP #6
1084961	\$ 25,949.19	2/27/2019	EDDY COUNTY DRUG TASK FORCE	G18SN0017A, RFP #6
1084962	\$ 7,638.71	2/27/2019	EDDY COUNTY DRUG TASK FORCE	G18SN0017A, RFP #6
1084963	\$ 17,658.74	2/27/2019	CITY OF ROSWELL	G18SN0017A, RFP #6
1084964	\$ 259.00	2/27/2019	FORKLIFT ENTERPRISES	MANLIFT MAINTENANCE
1084965	\$ 18,230.88	2/27/2019	PATTILLO BROWN & HILL L.L.P.	FINAL BILL FOR FY 2018 ANNUAL
1084966	\$ 680.00	2/27/2019	SUPERIOR PRINTING SERVICE INC	1,000 MOBILE HOME STICKERS
1084967	\$ 586.89	2/27/2019	THOMSON REUTERS	ACCT# 1000564698
1084968	\$ 1,120.60	2/27/2019	DAILEY WELLS COMMUNICATIONS	(12) RADIO CHARGERS, TRI CHEM
1084969	\$ 25.65	2/27/2019	R & R TROPHY	NAMETAG FOR A BURNETT/A MURILLO
1084970	\$ 5,333.94	2/27/2019	VERIZON WIRELESS	ACCT# 342061239-00001
1084971	\$ 204.18	2/27/2019	KLEIN AUTOMATION & ELECTRIC INC	TROUBLESHOOT INTERCOM AT
1084972	\$ 1,125.00	2/27/2019	TECHNICON TRAINING & CONS SER	CRIMINAL INVESTIGATIONS TRAINING
1084973	\$ 808.63	2/27/2019	BRADBURN, RONALD	6 - AMEREX ABC MODEL B456
1084974	\$ 13,650.00	2/27/2019	SOFTRESOURCES LLC	RFP# 07-(17-18)-EVAL ERP SYSTEM
1084975	\$ 31,352.00	2/27/2019	BRAD FRANCIS CHEVROLET	2018 CHEVROLET EXPRESS VAN
1084976	\$ 3,498.20	2/27/2019	FIRETROL PROTECTION SYSTEMS	REPAIR LEAK IN TANGO ALPHA
1084977	\$ 1,353.81	2/27/2019	PERMIAN FORD LINCOLN INC	REPLACE CYLINDER LOCK, FRONT END
1084978	\$ 431.00	2/27/2019	LUBBOCK DIAGNOSTIC RADIOLOGY	ACCT 5497 1912263
1084979	\$ 413.47	2/28/2019	APACHE SALES INC	COUPLING BODY, CHAIN, SOCKET SET
1084980	\$ 239.26	2/28/2019	AMERICAN MEDICAL GROUP, INC	URINALYSIS, VENIPUNCTURE
1084981	\$ 73.66	2/28/2019	BLAINE INDUSTRIAL SUPPLY INC	CLEANER, SPOT REMOVER, BOWL
1084982	\$ 82.98	2/28/2019	HOSE POWER USA	HOSE ASSEMBLY

County of Lea New Mexico
Accounts Payable Check Register February 2019

Check #	Check Amount	Check Date	Vendor Name	Transaction Description
1084983	\$ 3,217.50	2/28/2019	CARVER, RONALD C MD	NOVEMBER 2018 MEDICAL DIRECTOR
1084984	\$ 34.04	2/28/2019	FEDERAL EXPRESS CORPORATION	ACCT# 1622-6910-0
1084985	\$ 321.28	2/28/2019	HIGGINBOTHAM-BARTLETT CO NM INC	PUTTY KNIVES, WIPING CLOTHS
1084986	\$ 87.03	2/28/2019	HOBBS DAILY NEWS-SUN INC	LEGAL NOTICES
1084987	\$ 3,155.23	2/28/2019	INSITE TOWERS LLC	LEASE ID# 004901
1084988	\$ 138.91	2/28/2019	NM GAS COMPANY INC	ACCT# 074787613-0772001-7
1084989	\$ 7,150.24	2/28/2019	PETTIGREW & ASSOCIATES PA	SITE WORK NORTH PARKING LOT
1084990	\$ 137.64	2/28/2019	ROBERTS OIL & LUBE	OIL CHANGE UNIT T3
1084991	\$ 493.70	2/28/2019	W D ENTERPRISES INC	BATTERIES - FLEET
1084992	\$ 622.13	2/28/2019	TASCOSA OFFICE MACHINES	ACCT HB0045
1084993	\$ 478.84	2/28/2019	TDS	ACCT# 8224 20 004 0141367
1084994	\$ 701.76	2/28/2019	TAYLOR'S WEED & PEST CONTROL	WEED AND PEST CONTROL
1084995	\$ 550.09	2/28/2019	JETER, JIMMY	ICE MACHINE LEASE FOR KNOWLES FD
1084996	\$ 41.65	2/28/2019	PUGH, HOWELL R	2 - 5 GALLON WATER BOTTLES
1084997	\$ 579.76	2/28/2019	ALCOHOL MONITORING SYSTEMS INC	CAM DAILY MONITORING FEE
1084998	\$ 139.16	2/28/2019	STERICYCLE INC	FOR BIO HAZARD WASTE
1084999	\$ 695.39	2/28/2019	VERIZON WIRELESS	ACCT# 342081222-00001
1085000	\$ 78.99	2/28/2019	TASCOSA OFFICE MACHINES	CANON COPIER
1085001	\$ 438.34	2/28/2019	VERIZON WIRELESS	ACCT# 742111570-00001
1085002	\$ 85.84	2/28/2019	VERIZON WIRELESS	ACCT# 342061239-00002
1085003	\$ 149.70	2/28/2019	CITY OF HOBBS	ACCT# 016659-000
1085004	\$ 404.78	2/28/2019	CITY OF LOVINGTON	REIMBURSEMENT/OVERTIME FOR C
1085005	\$ 419.70	2/28/2019	AWESOME GRAPHICS LLC	GRAPHICS FOR K-9 UNIT CASTILLO
1085006	\$ 32.55	2/28/2019	MAIL SERVICES ETC	MAIL HIDTA RFP TO CARLSBAD
1085007	\$ 2,743.00	2/28/2019	PRUITT, HAROLD	ROT FENCE & GATE/REPLACE CHAIN
1085008	\$ 367.50	2/28/2019	WOOLDRIDGE, LISA M	LABOR TO DIAGNOSE ISSUES WITH
19671	\$ 306.00	2/27/2019	EZREGISTER	
19672	\$ 10.00	2/27/2019	ALBUQUERQUE PUBLISHING COMPANY	
19673	\$ 505.00	2/27/2019	PAYPAL	
19674	\$ 1.00	2/27/2019	CABQ PARKING STRUCTURE	
19675	\$ 1,828.65	2/27/2019	AMAZON MKTPLACE PMTS	
19676	\$ 262.28	2/27/2019	LANDS END BUS OUTFITTE	
19677	\$ 168.65	2/27/2019	WAL-MART STORES INC	
19678	\$ 34.50	2/27/2019	DAYLIGHT DONUTS	
19679	\$ 581.47	2/27/2019	ELLIOTT ELECTRIC SUPPLY INC	
19680	\$ 914.79	2/27/2019	HOME DEPOT #3515	
19681	\$ 201.76	2/27/2019	KIRKMEYER ELECTRIC INC	
19682	\$ 262.23	2/27/2019	STINE, JAMES M	
19683	\$ 482.25	2/27/2019	MASTER PLUMBERS	
19684	\$ 594.73	2/27/2019	HOMEDEPOT.COM	
19685	\$ 35.46	2/27/2019	SOUTHWESTERN TRAILER EQUIPMENT	
19686	\$ 1,178.52	2/27/2019	LOWE'S #03202	
19687	\$ 191.18	2/27/2019	TOM'S SHARP SHOP	
19688	\$ 1,134.00	2/27/2019	SQU SQ STITCHED BY BR	
19689	\$ 1,155.00	2/27/2019	TECHNICON TRAINING & CONS SER	
19690	\$ 23.33	2/27/2019	O'REILLY AUTO	
19691	\$ 3,084.86	2/27/2019	STAPLES	
19692	\$ 10.89	2/27/2019	HIGGINBOTHAM BARTLETT	
19693	\$ 1,626.50	2/27/2019	ZK EXPRESS TORNADO WASH LLC	
19694	\$ 890.30	2/27/2019	COMPLIANCESIGNS.COM	
19695	\$ 116.00	2/27/2019	RI NOVELTY/TOY NETWORK	
19696	\$ 55.97	2/27/2019	EL MIRADOR	
19697	\$ 764.49	2/27/2019	CROWN AWARDS INC	
19698	\$ 722.00	2/27/2019	AWESOME GRAPHICS LLC	
19699	\$ 125.99	2/27/2019	EXPRESS.COM	
19700	\$ 276.10	2/27/2019	CAVENDERS WESTERN #70	
19701	\$ 61.93	2/27/2019	GALLS	
19702	\$ 29.12	2/27/2019	KAUFMAN'S WEST	

County of Lea New Mexico
Accounts Payable Check Register February 2019

Check #	Check Amount	Check Date	Vendor Name	Transaction Description
19703	\$ 6,857.48	2/27/2019	STAPLES DIRECT	
19704	\$ 42.71	2/27/2019	PILOT	
19705	\$ 179.99	2/27/2019	ULTRA BRIGHT LIGHTZ	
19706	\$ 12.00	2/27/2019	DEL NORTE CAR CARE	
19707	\$ 1,072.82	2/27/2019	THIRTEEN TWENTY LLC	
19708	\$ 104.75	2/27/2019	BARRON SERVICE PARTS	
19709	\$ 131.11	2/27/2019	PERMIAN FORD LINCOLN INC	
19710	\$ 1,946.00	2/27/2019	INT IN ARTESIA FIRE E	
19711	\$ 229.90	2/27/2019	W D ENTERPRISES INC	
19712	\$ 492.83	2/27/2019	K W FUELS INC	
19713	\$ 4,449.21	2/27/2019	BLAINE INDUSTRIAL SUPPLY INC	
19714	\$ 198.64	2/27/2019	HAMPTON INNS	
19715	\$ 48.85	2/27/2019	5 STAR DONUTS & DELI	
19716	\$ 52.96	2/27/2019	SQ SQ JIMENEZ RANCHO	
19717	\$ 282.06	2/27/2019	4IMPRINT	
19718	\$ 90.79	2/27/2019	THE ROCK CENTER	
19719	\$ 1,460.30	2/27/2019	ICS JAIL SUPPLIES INC	
19720	\$ 70.00	2/27/2019	CLB NM FLOODPLAIN MGR	
19721	\$ 200.00	2/27/2019	NMSU CASHNET	
19722	\$ 450.00	2/27/2019	ACT LC2017	
19723	\$ 314.32	2/27/2019	AICPA AICPA	
19724	\$ 200.00	2/27/2019	FBI NATIONAL ACADEMY ASSOCIATES	
19725	\$ 3,784.84	2/27/2019	SHRM	
19726	\$ 149.00	2/27/2019	NM RURAL WATER ASSOCIATION	
19727	\$ 1,710.00	2/27/2019	AMERICAN ASSOC OF AIRPORT	
19728	\$ 200.00	2/27/2019	NMPPA	
19729	\$ 120.00	2/27/2019	SQU SQ NEW MEXICO EME	
19730	\$ 229.00	2/27/2019	THE PUBLIC SAFETY GROUP	
19731	\$ 1,327.39	2/27/2019	VISTAPR VISTAPRINT.COM	
19732	\$ 200.00	2/27/2019	RMIN	
19733	\$ 30.01	2/27/2019	ALLSUP'S CONVENIENCE STORES	
19734	\$ 119.88	2/27/2019	DNH GODADDY.COM	
19735	\$ 1,231.32	2/27/2019	SALSBURY INDUSTRIES	
19736	\$ 61.01	2/27/2019	SMITHS-DUEL	
19737	\$ 117.32	2/27/2019	O & S QUIK CHANGE, INC	
19738	\$ 49.43	2/27/2019	ALLSUP #117	
19739	\$ 726.73	2/27/2019	ELDORADO HOTEL	
19740	\$ 792.56	2/27/2019	HILTON GARDEN INN UPTO	
19741	\$ 1,746.32	2/27/2019	INN AND SPA AT LORRETO	
19742	\$ 81.54	2/27/2019	HOTWIRE-SALES FINAL	
19743	\$ 16.27	2/27/2019	HILLTOP BAR AND GRILLED	
19744	\$ 548.52	2/27/2019	LA FONDA HOTEL	
19745	\$ 346.32	2/27/2019	HOLIDAY INN EXPRESS	
19746	\$ 3,232.32	2/27/2019	DRURY INNS	
19747	\$ 107.04	2/27/2019	HYATT PLACE ALBUQUERQUE	
19748	\$ 1,240.43	2/27/2019	DOUBLETREE BY HILTON	
19749	\$ 872.02	2/27/2019	AMERICAN 00102735914650	
19750	\$ 22.32	2/27/2019	PANDA EXPRESS	
19751	\$ 35.00	2/27/2019	HOLIDAY INN AND SUITES	
19752	\$ 298.71	2/27/2019	HOLIDAY INN	
19753	\$ 461.76	2/27/2019	HILTON HOTEL SANTA FE	
19754	\$ 180.36	2/27/2019	EXPEDIA	
19755	\$ 477.34	2/27/2019	SAFETYDEPOT.COM	
19756	\$ 121.55	2/27/2019	U S POST OFFICE	
19757	\$ 61.75	2/27/2019	OFFICESUPPLY.COM	
19758	\$ 99.00	2/27/2019	DROPBOX	
19759	\$ 99.99	2/27/2019	SHALEXP	
19760	\$ 1.06	2/27/2019	APL ITUNES.COM/BILL	

County of Lea New Mexico
Accounts Payable Check Register February 2019

Check #	Check Amount	Check Date	Vendor Name	Transaction Description
19761	\$ 60.95	2/27/2019	OFFICE DEPOT #1080	
19762	\$ 619.93	2/27/2019	AMAZON.COM	
19763	\$ 221.00	2/27/2019	SQ SQ I CAN DO THAT	
19764	\$ 3.49	2/27/2019	ALBERTSONS #930	
19765	\$ 53.28	2/27/2019	WRISTCO	
19766	\$ 55.51	2/27/2019	MICHAELS.COM	
19767	\$ 432.95	2/27/2019	WALMART.COM	
19768	\$ 388.36	2/27/2019	PERSONALIZED PAPER STO	
19769	\$ 114.50	2/27/2019	HOBB NEWS SUN	
19770	\$ 288.37	2/27/2019	XPRESSMYSELF.COM LLC	
19771	\$ 362.34	2/27/2019	DRI PRINTING SERVICES	
19772	\$ 168.63	2/27/2019	DISPLAYS2GO	
Total	\$ 2,952,845.37			432

COMMISSION MAY CONVENE IN CLOSED SESSION to Discuss Threatened Litigation in Which the County May Become a Participant Regarding a Breach of Contract, as Authorized by the NMSA 1978 § 10-15-1 H (7).

COMMISSION MAY CONVENE IN OPEN SESSION to take Action, if any, on the Closed Session Item.





**LEA COUNTY BOARD OF COUNTY COMMISSIONERS
AGENDA ITEM SUMMARY FORM**

LCBCC Meeting Date: Thursday, March 21, 2019

Submit this summary form & all attachments to the Finance Director cjow@leacounty.net & cc the Executive Coordinator sstout@leacounty.net by: **March 5, 2019**

County Manager Approval (mgallagher@leacounty.net) required for all time sensitive issues that do not meet the above deadline.

DATE SUBMITTED mm-dd-yyyy: 03/19/2019		SUBMITTED BY Name/Title/Dept: Sandrea J. Stout-Brito/Executive Coordinator/Exec Dept.	
SUBJECT: Other Business		ATTACHMENT(S):	
NO. OF ORIGINALS FOR SIGNATURE: 00 ***Select One** 00 ***Select One** 00 ***Select One**		ACTION REQUESTED: Action Item	
STRATEGIC PLAN Implementation of 5 Year Strategic Plan: Section 2 - 6: Transparency and ethical decision making continue to be the framework in which the county operates.			
SUMMARY: Any Other Business			
Requested Items Needed for Presentation Easels/Laptop/Projector/Etc.: Easel <input type="checkbox"/> Laptop <input checked="" type="checkbox"/> Projector <input checked="" type="checkbox"/> Other: _____ <small>If checked; how many:</small>		See Additional Summary Attached <input type="checkbox"/>	
SUBMITTER'S RECOMMENDATION(S): Any Other Business		Submitter's Signature Department Director, Etc. 	
FINANCE REVIEW Fiscal Impact/Cost: ByPass Finance Review		Reviewed by Finance Director ByPass Finance Review Digitally signed by ByPass Finance Review Date: 2019.03.19 17:36:35 -06'00'	
LEGAL REVIEW: ByPass Legal Review (Note: Travel does not need legal review)		Reviewed by County Attorney ByPass Legal Review Digitally signed by ByPass Legal Review Date: 2019.03.19 17:36:45 -06'00'	
COUNTY MANAGER REVIEW:		Approved by County Manager to be Placed on Agenda Digitally signed by Michael P. Gallagher II Date: 2019.03.19 14:00:45 -06'00'	
Item 0500 RECORDING SECRETARY'S USE ONLY ~ COMMISSION ACTION TAKEN			
Approved: _____	Denied: _____	Other: <u>Discussion</u>	
Resolution No. _____	Policy No. _____	Ordinance No. _____	
Continued To: _____	Referred To: _____	Comments: _____	

Adjourn

1

