

Photography

Amateur, Open, Professional, Enhanced

Superintendent:

Processing Fee: Non-refundable \$4 per entry

Entry Deadline: Friday, August 31, 2018

Take-In Date: Saturday, September 15, 8am – 5pm



- Photos of offensive, controversial or objectionable nature or subject matter may not be accepted.
- All photos must have been taken between October 2017 and September 2018.
- **ENTRIES ARE LIMITED TO ONE PER CLASS. You may enter as many classes as you would like.**
- All photographs may be edited only to include cropping, adjusting contrast, sharpening the image, etc.
- All photos must be 8" x 10" or 8" x 12" – Any other sizes will be disqualified
- No frames
- No foam boards
- Construction paper is not acceptable matting
- All mats must be 11" x 14"
- Must be matted with no backing against the photograph (see example below)

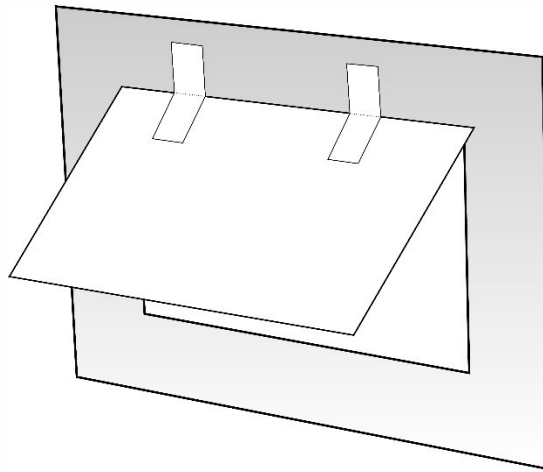

- Only one layer of matting is to be used – Multiple layers will be disqualified
- All portraits must have a model release form. Only exception is photography of your own children.
- All photos must have the exhibitor's name, division and class on the back bottom right hand corner.

Definitions

- Youth – Younger than 18 years old on the day of take-in (Sept. 15th, 2018)
- Senior Citizen – 62 years of age or older on the day of take-in (Sept. 15th, 2018)
- Adult – 18 years or older on the day of take-in (Sept. 15th, 2018)
- Amateur – Two years or less experience. Exhibitors are only allowed to enter as an amateur for two years.
- Open – More than two years' experience, hobbyist.

- Professional – Collects more than 50% of annual income from photography services or business or presents oneself to the public as a professional.
- Enhanced – Digitally manipulating or altering the image. The content of the picture is changed significantly from the original, either by dramatic change in content, select colorization, high dynamic range, compositing, or other methods that alter the image/incorporate multiple photos into a single image.
- Unclassified – Does not fit any other category listed. May not be used as a secondary class for a photo that fits into another class that you have already entered



Judging Criteria

- Originality – 30%
 - Impact on viewer, unique approach to subject matter
- Execution Quality – 30%
 - Technique, craftsmanship, excellent mastery and application of photographic skills and principles
- Composition – 30%
 - Arrangement and balance of visual elements
- Presentation – 10%
 - Prepared and secured neatly to meet requirements