

Horticulture Display Guidelines for Plant Societies, Guilds & Organizations

updated 10/3/19



Display Information:

- All displays should be educational artistically designed.
- The display will be maintained by the society or organization at a high standard of quality for the duration of the fair. **A set-up premium of \$350.00 will be paid to each society.**
- All displays will be inside the Florida Center building.
- The fair will not provide the mulch for the displays.
- Societies, Guilds and organizations are welcome to be at their display any time during the fair. This is a great way to share information and create public awareness.
- The display location will be assigned after all applications are confirmed. The size of the display will be 10' x 10'.

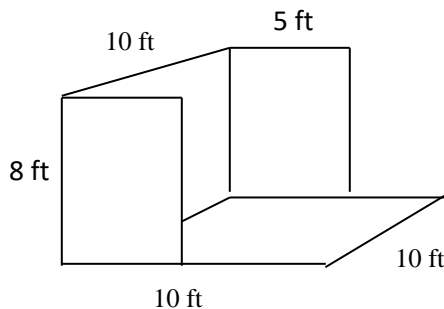

Attention

All water must be retained within your booth.
You may use pot trays.

Schedule

Confirm that your organization will be participating in the plant display	December 31, 2019 (TUES)
Display setup	January 31 – February 4, 2020 (FRI – TUES) 10:00 a.m. – 9:00 p.m.
People's Choice	February 6-17, 2020
All displays must be removed completely (including mulch)	February 18 - 19, 2019 (TUES & WED) 10:00 a.m. – 9:00 p.m.

Awards

People's Choice Award	\$150
-----------------------	--------------

For any additional information or questions, please call Brenda Gregory at (813) 734-2810, or email: brenda.gregory@floridastatefair.com.

2020 Horticulture Display Application



A completed application should be received by Tuesday, December 31st.

Mail completed form back to:

Florida State Fair – Horticulture Display
Attn: Brenda Gregory
P.O. Box 11766
Tampa, FL 33680

Scan & Email to:

brenda.gregory@floridastatefair.com

Name of Society, Guild or Organization

Contact Person

Who does the check get written out to?

Address

City

State

Zip code

Cell Phone

Email

Organization Website or Facebook Page

How many Fair tickets will you need for your organization to care for your display during the Fair? _____

Will you need a **LOAD IN/LOAD OUT Pass** for the Florida Center building during Fair? YES NO **How many?** ____

NOTE: Each vehicle will need only one Pass with the dates that they will be allowed access (we usually provide access the entire Fair dates).

How many years have you participated in the Florida State Fair? _____ We are new to the Fair.

Will you need electricity for your display? YES NO

List any special needs _____

What days can you staff your display? FEB 6 FEB 7 FEB 8 FEB 9 FEB 10 FEB 11

FEB 12 FEB 13 FEB 14 FEB 15 FEB 16 FEB 17